

INTERNATIONAL COURT OF JUSTICE

**APPLICATION OF THE INTERNATIONAL CONVENTION FOR THE SUPPRESSION
OF THE FINANCING OF TERRORISM AND OF THE INTERNATIONAL
CONVENTION ON THE ELIMINATION OF ALL FORMS OF RACIAL
DISCRIMINATION**

(UKRAINE V. RUSSIAN FEDERATION)

REJOINDER

SUBMITTED BY THE RUSSIAN FEDERATION

VOLUME VII

(ANNEXES 42 - 176)

10 MARCH 2023

TABLE OF CONTENTS

VOLUME VII

Annexes 42-176

- Annex 42 *Vzglyad, Seven Major War Crimes Committed by Ukraine against Donbass Residents* (8 May 2022).
- Annex 43 *Lostarmour, Shelling of the Mirny and Gaevogo Quarters by Grad MLRS Units on 14 July 2014* (29 November 2021).
- Annex 44 *LiveJournal, Lest We Forget – How Lugansk Was Shelled in July 2014* (15 July 2018).
- Annex 45 *MigNews, Mirny and Gaevogo Quarters Attacked by Grad MLRS in Lugansk. PHOTOS. VIDEOS* (15 July 2014).
- Annex 46 *VESTI.ru, Airstrike at Snezhnoye: Militiamen Report Dead Civilians* (15 July 2014).
- Annex 47 *RT, “Still No Answer”: Eighth Anniversary of Tragic Shelling of Children Beach in Zugres* (13 August 2022).
- Annex 48 *TASS, Ukrainian Shelling Killed at Least 11 in Donetsk* (28 August 2014).
- Annex 49 Letter from the Office of the Prosecutor General of the Russian Federation No. 82/1-5094-15, 7 February 2017.
- Annex 50 Letter from the Office of the Prosecutor General of the Russian Federation **No. 82/1-5100-15**, 20 October 2016.
- Annex 51 Letter from the Office of the Prosecutor-General of the Russian Federation No. 82/1-5095-15, 18 November 2016.
- Annex 52 Letter from the Office of the Prosecutor-General of the Russian Federation No. 82/1-5099-15 dated 16 November 2016.
- Annex 53 Letter from the Office of the Prosecutor-General of the Russian Federation No. 87-200-2015, 29 February 2016.
- Annex 54 Letter from the Office of the Prosecutor-General of the Russian Federation No. 82/1-2791-15, 25 September 2015.
- Annex 55 Letter from the Office of the Prosecutor-General of the Russian Federation No. 82/1-1897-17, 28 February 2019.
- Annex 56 Letter from the Office of the Prosecutor-General of the Russian Federation No. 82/1-5598-17, 19 December 2018.

- Annex 57 Letter from the Office of the Prosecutor-General of the Russian Federation No. 82/1-580-17, 22 June 2017.
- Annex 58 Letter from the Office of the Prosecutor-General of the Russian Federation No. 82/1-3545-15, 11 February 2016.
- Annex 59 Letter from the Office of the Prosecutor-General of the Russian Federation No. 82-1-2445-15 dated 17 February 2016.
- Annex 60 All-Russian Population Information Classifier
- Annex 61 Code of Administrative Proceedings of the Russian Federation, 8 March 2015
- Annex 62 Ministry of Education, Science and Youth of the Republic of Crimea, On the state of education in the state languages of the Republic of Crimea (Russian, Ukrainian, Crimean Tatar) and the study of native languages of the peoples of the Russian Federation living in the Republic of Crimea in general education institutions of the Republic of Crimea in the academic year 2021/2022.
- Annex 63 Ministry of Education, Science and Youth of the Republic of Crimea, Information on the Students Studying in the State Languages of the Republic of Crimea (Russian, Ukrainian, Crimean Tatar) in General Educational Institutions of the Republic of Crimea in the 2022/2023 School Year.
- Annex 64 Crimean Federal University, Allocation of budgetary places in the bachelor's and specialist's programme in 2023 (full-time programmes).
- Annex 65 Crimean Federal University, Allocation of budgetary places in the bachelor's and specialist's programme in 2023 (extramural programmes).
- Annex 66 Crimean Engineering and Pedagogical University, Number of places for admission for the 2023/2024 academic year.
- Annex 67 Decree of the Council of Ministers of the Republic of Crimea No. 658 “On Approval of the Regulations on the Remuneration System for Employees of State Budgetary and Autonomous Educational Organizations of the Republic of Crimea”, 30 December 2014.
- Annex 68 International Affairs, Republic of Crimea: Education in Native Languages (12 November 2019).
- Annex 69 Supreme Court of the Russian Federation, Cassation Ruling No. 33-UD22-11-A2, 28 June 2022.
- Annex 70 Unian, *Ukraine Cannot Do without Coal from the Occupied Territories - Head of the SBU* (26 January 2017).

- Annex 71 Zaxid.net, *Deputy Prime Minister says how much coal Ukraine buys from the occupied territories* (16 December 2016).
- Annex 72 Cenzor.net, *Chernysh is Against Ban on Goods Transportation Through Contact Line* (26 December 2019).
- Annex 73 Ukrainian railway, *Due to the blocking of train traffic in the Donbass, Ukraine did not receive almost 240 thousand tons of thermal coal, and the industry suffered UAH 53.5 million in losses* (15 February 2017).
- Annex 74 Slovo i dilo, *Coal case of Poroshenko-Medvedchuk: details of procurement announced by SBI* (17 January 2022).
- Annex 75 Hromadske, *"Coal case": Poroshenko was appointed a personal obligation* (19 January 2022).
- Annex 76 NRC, *Aid workers are staying in Afghanistan - as they do in crises globally. We must protect them* (30 August 2021).
- Annex 77 AIF.RU, *Ukrainian Barbarians. Ukrainian nationalists demolish Lenin monument in Kharkov* (29 September 2014).
- Annex 78 Ukrainian Pravda, *Journalist Babchenko is alive, the Murder is Staged* (30 May 2018).
- Annex 79 Polit.ru, *"Kharkiv Partisans" Disclaim Responsibility for Terrorist Attack in Kharkiv* (23 February 2015).
- Annex 80 Korrespondent.net, *SSU Has Tortured Marina Kovtun Accused of Blowing up Stena Rock Pub for Three Years* (22 November 2017).
- Annex 81 BAGNET, *Kharkov terrorists may have been helped by police officers* (22 November 2014).
- Annex 82 Ukranews.com, *Kharkov Police Officer Kept Mine at Home* (22 November 2014).
- Annex 83 Ukraine.ru, *11 years for a note. Political prisoner Kovtun convicted in Kharkov on falsified evidence* (10 October 2019).
- Annex 84 5140.org, *Baranenko Andrii Volodymyrovych* (25 January 2023).
- Annex 85 Anti-fascist, *Kharkiv political prisoner Marina Kovtun is to be sentenced on 7 October. The prosecutor's office requested 12 years in prison* (2 October 2019).
- Annex 86 Interfax.ru, *PrivatBank branch shelled in Kharkov* (28 July 2018).
- Annex 87 Sm.news, *AFU uses MON-50, MON-100 and Claymore on drones* (24 December 2022).

- Annex 88 Ukraina.ru, *Gerashchenko Could Stage Attempt on Him* (22 January 2017).
- Annex 89 Sila v Pravde, *Attempt on Gerashchenko Was Feign Staged by SSU and Interior Ministry* (22 January 2017).
- Annex 90 Ukrainski Novini, *Assassination Attempt on Gerashchenko Could Be Staged* (22 January 2017).
- Annex 91 Criminal Code of Ukraine, 5 April 2001.
- Annex 92 Slovo i Delo, *Assassination Attempt on Anton Gerashchenko. Was It Real?* (23 January 2017).
- Annex 93 The Guardian, *Arkady Babchenko Reveals He Faked His Death to Thwart Moscow Plot* (2018).
- Annex 94 The Guardian, *Ukraine Clashes: Dozens Dead after Odessa Building Fire* (2014).
- Annex 95 BBC News, *Ukraine Crisis: Russia Condemns Attack on Kiev Embassy* (2014).
- Annex 96 NV, *"Where it will be comfortable." Kremlin called on opponents of the language law to leave Ukraine* (6 August 2021).
- Annex 97 Law No. 2827–IX “On National Minorities (Communities) of Ukraine”, 13 December 2022.
- Annex 98 Krymsky Analitik, *Photos. Crimean Tatars Demand that Yushchenko and Tymoshenko Stop Racial Discrimination in Ukraine* (18 May 2009).
- Annex 99 Ukraina.ru, *Dzhemilev and the West are trying to prevent Crimea from joining Russia* (28 November 2014).
- Annex 100 Sprotyv.info, *Traitors will flee Crimea even sooner than Russian soldiers – Chubarov* (8 May 2017).
- Annex 101 Bigmir.net, *Chubarov: It is necessary to establish criminal liability for collaborators* (10 April 2016).
- Annex 102 RIA Novosti Crimea, *The Head of the Mejlis named the condition for the resumption of water supply to Crimea* (30 June 2019).
- Annex 103 RIA Novosti Crimea, *“Right Sector” reported that “Azov” had joined the blockade of Crimea* (1 October 2015).
- Annex 104 Komsomolskaya Pravda, *“Immortal Regiment 2018” in Crimea: Route and Time* (3 May 2018).

- Annex 105 KP.ua, *Rally in Memory of Deportation Victims Took Place in Crimea* (18 May 2013).
- Annex 106 Avdet, *So that the youth remember* (26 February 2000).
- Annex 107 Mejlis, *Over 40,000 people took part in All-Crimean mourning rally dedicated to the 69th anniversary of the deportation of Crimean Tatars* (18 May 2013).
- Annex 108 Milli Firka, *Mejlismen want Mogilev's resignation* (7 May 2013).
- Annex 109 BBC, *Anniversary of deportation: Crimean Tatars want Mogilev's resignation - BBC News Ukraine* (17 May 2013).
- Annex 110 Centre for Investigative Journalism, *Mejlis gives authorities 10 days to demolish Lenin monuments in Crimea - Centre for Investigative Journalism* (23 February 2014).
- Annex 111 Haberler, *The Organising Committee Has Filed Another Application for the Celebration* (3 June 2015).
- Annex 112 Gorod 24, *Simferopol Celebrates Taras Shevchenko's Birthday* (10 March 2022).
- Annex 113 Millet, *Khizmet ve Bereket, TV Programme of 18 November 2022, Ayder Ismailov* (18 November 2022).
- Annex 114 Millet, *Prime Time. TV Programme of 24 November 2022, Eldar Seitbekirov* (25 November 2022).
- Annex 115 Millet, *Ana Yurtun – Altyn Beshik, Episode 28, Remzi Devletov* (21 November 2022).
- Annex 116 Millet, *Tek arzum Watan!, TV Programme of 17 November 2022, Eskender Tarakchiev* (21 November).
- Annex 117 Millet, *Prime Time. TV Programme of 22 September 2022. Ruslan Yakubov* (23 September 2022).
- Annex 118 Crimea Newsfeed, *Third Open Festival-Contest of Children's Folklore Groups 'Crimean Terem' held in Crimea* (3 December 2018).
- Annex 119 Kerch Education and Training Complex Boarding School-Lyceum of Arts, *"Pearl of Crimea" Dance Ensemble – Winner of the Republican Contest "Crimean Terem"* (6 December 2019).
- Annex 120 Krym Realii, *Ukrainian and European dances performed in Sevastopol (+video)* (24 March 2018).
- Annex 121 Avdet, *Crimean Tatars cherish their language so much that they don't even speak it* (24 June 2013).

- Annex 122 Interfax, *Crimean Historical Textbook to Get Rid of Chapter Insulting Crimean Tatars* (6 May 2019).
- Annex 123 Roskomnadzor, *232 Registered Media Outlets Operating in Crimea* (2 April 2015).
- Annex 124 Roskomnadzor, Letter dated 26 March 2015 No. 571-05-91.
- Annex 125 Roskomnadzor, Report on Registration of Media Outlets, 3rd Quarter of 2017.
- Annex 126 Bez Formata, *Crimean Schools Got Over 80,000 Textbooks in Crimean Tatar Language* (16 January 2018).
- Annex 127 Roskomnadzor, Report on Registration of Media Outlets, 4rd Quarter of 2017.
- Annex 128 Roskomnadzor, *232 Registered Media Outlets Operating in Crimea* (2 April 2015).
- Annex 129 BBC News, *Crimea Hit by Power Blackout and Ukraine Trade Boycott* (23 November 2015).
- Annex 130 Roskomnadzor, *483 Registered Media Outlets Operating in Crimea* (18 March 2017).
- Annex 131 Avdet, *Newspaper No 27 of 29 September 2020* (30 September 2020).
- Annex 132 Millet, *Vatan Khatirasi* (17 February 2023).
- Annex 133 Millet, *History of the Crimean Tatars Programme* (17 February 2023).
- Annex 134 Millet, *Crimean family* (17 February 2023).
- Annex 135 Millet, *Kirimda Bayram* (17 February 2023).
- Annex 136 Millet, *Millet Bereketi* (17 February 2023).
- Annex 137 Millet, *The Peoples of Crimea: Diversity of Unity* (17 February 2023).
- Annex 138 Millet, *Prime Time* (17 February 2023).
- Annex 139 Millet, *Seyaata* (17 February 2023).
- Annex 140 Millet, *Tarikh Izleri* (17 February 2023).
- Annex 141 Millet, *Tek Arzum Vatan* (17 February 2023).
- Annex 142 Millet, *Yurt Nefesi* (17 February 2023).
- Annex 143 Millet, *Yaylya Boyu* (17 February 2023).

- Annex 144 Millet, *Chalgidzhi Live* (17 February 2023).
- Annex 145 Millet, *Ana Yurtun - Altin Beshik* (17 February 2023).
- Annex 146 Millet, *Diniy Subet* (17 February 2023).
- Annex 147 Millet, *The World of Islam* (17 February 2023).
- Annex 148 Millet, *Khizmet ve Bereket* (17 February 2023).
- Annex 149 Millet, *Millet Khatirlyay* (17 February 2023).
- Annex 150 Millet, *Miras* (17 February 2023).
- Annex 151 Millet, *Yerketay* (17 February 2023).
- Annex 152 Millet, *Yuku Time* (17 February 2023).
- Annex 153 Millet, *Documentary "The Long Way Home"* (18 May 2022).
- Annex 154 Millet, *Documentary "Fevzi Bilyalov: Singer for All Times..."* (5 November 2022).
- Annex 155 Investigative Journalism Centre, *BSTRC Threatened with Discontinuation of Broadcasting in Crimea* (13 January 2014).
- Annex 156 Investigative Journalism Centre, *Employees of BSTRC, Crimea's Largest TV Company, Walked Out* (7 February 2013).
- Annex 157 Taurica.net, *BSTRC Begins Repaying Debts to RTTC* (20 January 2014).
- Annex 158 Odessa Crisis Media Center, *"We'll Return Crimea in 2016", Says Lenur Islyamov* (25 December 2015).
- Annex 159 Facebook, *ATR TV Channel, "This Is Our Second Victory. First One Was Trade Blockade of Crimea", Liza Bogutskaya Says* (17 August 2017).
- Annex 160 Tatar-inform.ru, *Mufti of Crimea: "We cannot repeat the mistake we made in 1783"* (13 August 2022).
- Annex 161 TASS, *Head of the Council of Muftis of the Russian Federation: Crimean Tatars will be able to regain ownership of their mosques* (1 April 2014).
- Annex 162 RIA, *Mufti Speaks about Restoration of Khan's Palace in Crimea* (17 February 2022).
- Annex 163 Suspilne Krym, *Second Floor of Lesya Ukrainka Museum in Occupied Yalta Closed for Almost Five Years* (25 February 2022).

- Annex 164 Mejlis, *News* (9 September 2013).
- Annex 165 Mejlis, *Procedure for Holding 18 May 2014 Memorial Events Dedicated to the Memory of Crimean Tatar People Genocide Victims* (17 May 2014).
- Annex 166 Mejlis, “*No Nation Can Exist without Its Historical Memory*”, *Refat Chubarov* (18 May 2014).
- Annex 167 Euronews, *UN Adopts Russian-drafted Resolution on Ukraine Crisis* (17 February 2015).
- Annex 168 Telegraf, *Poltorak on Disengagement: Agreements with Aggressor are Worth Nothing* (20 October 2016).
- Annex 169 Ukrinform, *Reznikov: Only Normandy Four Leaders Can Change Minsk Agreements* (11 July 2020).
- Annex 170 Ukrinform, *Poroshenko Says Minsk Agreements Partially Fulfilled Their Goal* (13 December 2019).
- Annex 171 Russia Today, *Minsk Deal Was Used to Buy Time – Ukraine's Poroshenko* (17 June 2022).
- Annex 172 Roskomnadzor, *Data on media outlets registration between 01.01.2016 and 31.12.2016*.
- Annex 173 ANO OKTRK, *Letter*, 8 February 2023.
- Annex 174 NTS, *Scientists Discover Secrets of Ancient Necropolis on Tavrida Highway near Sevastopol – Sevastopol Independent TV* (13 July 2018)
- Annex 175 Russian Gazette, *3,500+ Years Old Artefacts Found on Tavrida Highway Construction Site* (20 May 2021)
- Annex 176 AMNESTY International, *Ukraine: Ukrainian fighting tactics endanger civilians* (4 August 2022).

Annex 42

Vzglyad, *Seven Major War Crimes Committed by Ukraine against Donbass Residents* (8 May 2022)

(translation)

Translation

Vzglyad, Seven Major War Crimes Committed by Ukraine against Donbass Residents (8 May 2022), available at: <https://vz.ru/society/2022/5/8/1157166.html>.

Seven Major War Crimes Committed by Ukraine against Donbass Residents



8 May 2022 at 09:30 AM

Photo by the Office of the President of Ukraine/Reuters

Text by Arthur Pryimak and Rafael Fakhruudinov

Western media are currently eager to disseminate any Ukrainian fake news about the crimes allegedly committed by the Russian Army in Ukraine. In doing so, they neglect the crimes committed by the Armed Forces of Ukraine (AFU) and neo-Nazis during the eight years of the Donbass conflict. However, in contrast to the speculative accusations against Russia, these were real mass killings of civilians and refined tortures of innocent people.

Last Friday Russian diplomats reminded the global community about the crimes committed by Ukrainian military personnel and nationalist fighters. The UN Security Council held what is called in everyday diplomatic speech an “Arria formula” meeting where a UN Security Council member state (in this particular case, Russia) informally invites “those persons who would be useful to hear”. In this particular case, these were European and Arabic journalists who have visited the liberated areas in Donbass and Ukraine. According to a TASS report, they presented video interviews with local residents telling how AFU soldiers fired at the cars of those people trying to escape via humanitarian corridors.

“Many spectators witness that the Ukrainian Army uses civilians as hostages forming a living shield”, said Vasily Nebenzya, Permanent Representative of Russia to the United Nations. According to the eyewitnesses of the war crimes, the hostage taking was not a spontaneous excess but an action taken according to a well-established scheme: for instance, they placed armoured vehicles on the ground floors of residential buildings while holding people as a living shield on the middle floors and positioning snipers and soldiers with MANPADS on the rooftops.

“Today, we will not speak ourselves but give the floor to those people who have lived out in person what happened on the frontline to tell us how they survived and who committed the atrocities. Those words will not be ours. If you do not want to hear that, that is another story. If you prefer to remain comfortably silent, that is your choice”, Mr. Nebenzya told the participants of the meeting from Western states when they began routinely accusing the Russian delegation of “disseminating false information”.

During the last days, the West aggressively blamed Russia, including via various international organisations, for the death of civilians in the course of the special military operation and even for the alleged war crimes. “The Mission of the Office of the UN High Commissioner for Human Rights (OHCHR) continues checking the reports of violations of international law, human rights and international humanitarian law”, said Michelle Bachelet, UN High Commissioner for Human Rights, at the UN Security Council meeting on Thursday. “In the context of the armed attack by the Russian Federation on Ukraine, many of those accusations concern violations that may be recognised to be war crimes”.

Tellingly, Ms. Bachelet relayed the Ukrainian position as she mentioned the “strike” at the dramatic theatre in Mariupol (despite the fact that the visual inspection of the building showed no characteristic signs of a missile attack), the missile strike at the railway station in Kramatorsk (which was attacked by a Ukrainian Tochka-U missile), and the events at Bucha.

Russia points out that the West neglects what had happened in Donbass since the spring of 2014 when Kiev decided to respond by force to the Donbass people’s desire to gain independence (by the way, the 11th of May will be the eighth anniversary of the referendum on independence held in the Donetsk and Lugansk Peoples’ Republics). According to official data, up to 3,400 civilians were killed in the conflict zone during those years. “Over the last eight years, the AFU committed a lot of actions constituting war crimes under international humanitarian law”, Maxim Grigoriev, the head of the International Public Tribunal on Ukraine (IPTU) and a member of the Russian Public Chamber, told *Vzglyad*.

The IPTU has interrogated more than 300 eyewitnesses and sufferers of the crimes committed by the AFU and Ukrainian nationalist battalions, Mr. Grigoriev said. “For example, we conducted the relevant interviews in the liberated town of Volnovakha. The locals told us how the AFU fired at the town hospital and residential buildings. We separately investigated into the episode when a moving Ukrainian tank fired at civilians on the move and never trying to hide. It was eventually knocked out by the DPR people’s militia”, he added.

“Many reports say about wilful murders of civilians by Ukrainian military personnel”, Mr. Grigoriev said. “There are witness statements that the AFU and Azov Nationalist Battalion snipers killed children of the age of three to five together with their parents and that the Ukrainian Army fires the residential areas and mined residential buildings. They also purposefully fired at women and children trying to escape and massive human convoys leaving the places of warfighting”.

According to Mr. Grigoriev, Ukrainian forces also mined the places where people took water and did not let civilians to escape from buildings housing Ukrainian forces, including those on fire. “They also widely practise the use of civilians as a living shield. They forcedly held civilians and fire from behind of them. Massive robberies of civilians by Ukrainian military personnel are also war crimes. We are aware of dozens of thousands such events in Mariupol, Volnovakha and other cities and towns. Attacks on medical personnel and hospitals and

destruction of civil infrastructures – Ukrainian forces leave scorched earth behind them”, he noted.

The long chronicle of the crimes committed by the “champions of Ukraine” includes looting, abuse of civilians and purposeful shelling of cities and towns containing no military targets. However, some of those crimes are so cruel and inhuman that they stand out among the other horrors of war.

1. The First Air Strike against the Lugansk RSA

On 2 June 2014, Inna Kukurudza, a civilian from Lugansk, was killed by an air strike committed by the Ukrainian Air Forces when she passed by the building of the Lugansk Regional State Administration (RSA). She died *en route* to a hospital after the air bomb tore away both of her legs. On the same day, the Ukrainian air strikes at Lugansk killed eight and heavily wounded 28 civilians. The city was bombed by two Su-27 aircraft of the 831st Tactic Air Brigade. The crews were then commanded by Alexander Oksanchenko and Oleg Yalyshev. AFU Colonel Oksanchenko was killed by the Russian Army in the air on 1 March 2022.

The information on that event by Kiev media became one of the first examples of Ukrainian military fake news. Mr. Seleznyov, the then speaker of the headquarters of the “anti-terrorist operation”, stated that “ATO forces never fire at residential areas in cities and towns and never use air forces there”. In their initial comment, Ukrainian officials tried to explain the disaster by an “explosion of an air conditioner”.

2. “Madonna of Gorlovka”

On 27 July 2014, a massive shelling of a residential area in Gorlovka by the Ukrainian Army killed Kristina Zhuk, a young mother who was 27 years old, and Kira, her daughter who was only 10 months of age. Kristina Zhuk has become posthumously known in Russia and Donbass as the “Madonna of Gorlovka”. On that day, which became a day of lamenting and went down in the history of the town as “Bloody Sunday”, over 20 civilians were killed in Gorlovka.

In addition, in August 2014, Zugres, a small town of in Donbass, became a target for the Ukrainian Air Forces. The Ukrainian Army also shelled the town beach where many families with children were then taking rest. On that day, 21 people were killed, including three children, and another 40 were wounded.

3. The Ukrainian Missile Attack on Mariupol

On 24 January 2015, the AFU launched MLRS attacks on Mariupol’s residential quarters from their positions located north and west of the city. The attacks took place in the morning and daytime of that day, with the Azov Nationalist Battalion being engaged to “get things shaped up” in the places shelled. Electricity and water supply were suddenly cut off the day before in the attacked districts. According to the Mariupol ambulance service, 46 were killed and about 100 were wounded. The Kiev regime accused the “Russian troops” of that war crime.

4. The Crimes Committed by the Tornado Battalion

The Tornado Battalion, a Ukrainian police squad, has committed crimes that horrified even the Kiev authorities who had established it. In the hospitals in the settlement of Kondrashovka and

the district central town of Stanitsa Luganska as well as in the towns of Pryvillia and Lysychansk, they created torture chambers where nationalist butchers competed with each other in using the fiercest tortures against Donbass civilians. For example, Tornado took many civilians hostage after the fights for the DPR town of Maryinka in 2014.

Anatoly Matios, the former Ukrainian Military Prosecutor, witnessed: "... They beat the detainees on their legs, buttocks, hips and genitals. Men were also tortured with electric shockers. Those held in the basement were stripped naked, placed on a concrete floor and doused with water. After that, butchers touched various parts of their bodies with live wires".

"When Tornado's commanders were arrested, we seized their mobile phones where we found horrifying videos which are now part of the case file evidence. Those videos depicted various sexual orgies and rapes. I must say, even infants were there. They raped minor girls... Those people were animals, not humans", admitted Tetiana Chornovol, a former deputy of the Ukrainian Verkhovna Rada from Arseniy Yatsenyuk's People's Front.

5. The Crimes Committed by the AFU against Children

In July and August 2014, the AFU purposefully attacked School No. 7 that was used as a refuge by those Lugansk residents who had lost their homes. There were many children among the people sheltering in the school. The attack killed six people and virtually destroyed the school.

On 5 November 2014, an attack by the AFU against School No. 63 in Donetsk killed Daniil Kuznetsov (14) and Andrey Yeliseev (18) and wounded five other schoolchildren. On 5 April 2014, a homemade bomb was dropped from a Ukrainian unmanned air vehicle (UAV) and killed Vladislav Shikhov (5) walking with his grandmother in the settlement of Alexandrovskoye, DPR. The UAV was launched from the position taken by the AFU's 59th Jakiv Gandzyuk Separate Mechanised Brigade. On 31 May 2021, the AFU attacked a school and a daycare centre in the settlement of Zolotoye-5 in the LPR where there were children at that time.

6. The Use of Prohibited Weapons

On 29 July 2014, the western side of Donetsk was attacked from air by prohibited phosphorus bombs launched by the AFU. The Ukrainian Army has aggressively used phosphorus ammunition, anti-personnel landmines and other weapons prohibited by international conventions in Donbass since 2014.

It is worth noting that the AFU continue to use prohibited weapons. On 5 April 2022, they used phosphorus bombs and petal mines during the fights for the town of Popasna on the border between the LPR and the Kharkov Region.

7. The "Library" and Other Secret Concentration Camps

According to Vasily Prozorov, a former officer of the Security Service of Ukraine (SSU), the Azov Nationalist Battalion established a secret concentration camp called "Library" in the Mariupol airport. Captured militiamen of the LPR and DPR and civilians suspected of sympathy for Russia were detained there. The prisoners were kept in disabled freezers that did not allow heat and air to pass through. A prisoner could be released if his or her relatives brought a large

ransom demanded by Azov; the average amount of ransom ranged from about USD 2,000 to USD 3,000.

Standard tortures were something like this. The torturers laid a prisoner on the floor, covered his or her face with a rag so that he or she could not breathe through his or her mouth and nose and poured water on the rag. The victims usually had a micro-stroke after such torture. They also put prisoners with their palms on a rail and thrown another rail from a height so that the bones of their fingers broke. They also could sawn off their hands and feet with a grinder. The tortures were carried out by Azov during interrogations with prejudice, and SSU officers recorded the testimonies of the victims. Azov girls enrolled as “medics” were also involved in the torturing.

According to the witness statements of survivors, concentration camps like the “Library” were also operated in abandoned resorts near Mariupol where Azov, Aidar, Donbass, Tornado and other AFU and National Guard formations composed of Ukrainian nationalists were located.

In each concentration camp, the tortures were similar to those practised by Gestapo.

The AFU’s Aidar 24th Separate Assault Battalion established a secret concentration camp in the settlement of Polovinkino in the Starobelsk District of the LPR. The camp was located on the premises of the former sausage factory. The outer perimeter of the concentration camp was fenced with barbed wires, and there was a forbidden zone along the inner perimeter the crossing of which was punishable by death for the prisoner. The prisoners were kept in cramped, stuffy cells with no windows. The victims of Aidar relieved themselves in the same place where they were kept. During the so-called “quarantine”, when a prisoner only found himself in a concentration camp, he was not given any food for a week or two. A prisoner could also be poisoned to death through food. Interrogations and tortures took place in a former smokehouse. Aidar provoked prisoners to commit suicide by tortures and humiliation. The walls of the premises for the guards were covered with billboards calling for murder of all Russians and Russian-speaking people.

We may add that, over the last eight years, the Investigative Committee of Russia (ICR) has already opened about 800 criminal cases related to the events in Donbass and Ukraine. In total, 287 people have now become defendants in those cases, and almost half of them have been charged. 115 persons are involved in those crimes against the peace and security of mankind which have no period of limitation, and decisions to bring 63 of them on trial have been made, according to Alexander Bastrykin, the head of the ICR.

“Over the entire period of the investigation, more than 146,000 people have been interrogated, and more than 22,000, including over 2,400 minors, have been recognised as victims”, an ICR report says. 7,500 complaints have been submitted to the ECHR against Ukraine, RIA Novosti reports.

According to Dmitry Kalashnikov, the head of the DPR Forensic Medical Examination Bureau, about 5,000 and 2,000 examinations of the bodies of the dead have been carried out in the DPR and the LPR, respectively, with 2,000 more bodies remaining unidentified, IT reports.

Annex 43

Lostarmour, *Shelling of the Mirny and Gaevogo Quarters by Grad MLRS Units on 14 July 2014*
(29 November 2021)

(translation)

Translation

Lostarmour, *Shelling of the Mirny and Gaevogo Quarters by Grad MLRS Units on 14 July 2014* (29 November 2021), available at: https://lostarmour.info/articles/obstrel-kvartalov-mirnyy-i-gaevogo-goroda-luganska-s-primeneniem-rszo-grad-14-iyulya-2014-goda#_ftn3.

Shelling of the Mirny and Gaevogo Quarters by Grad MLRS Units on 14 July 2014



PUBLIC INVESTIGATION REPORT

Donetsk, 29 November 2021

By Ivan Kopyl

PREAMBLE

On the 13th and 14th of July 2014, Ukrainian armed formations (UAFs) made an attempt to de-block the Lugansk airport [1]. They attacked from Slovianoserbsk along the western outskirts of Lugansk. In the course of that operation, Lugansk was subjected to massive shellings that **killed and wounded civilians**, impaired infrastructure, and destroyed and damaged civilian facilities [2].

On 14 July 2014, the shellings of Lugansk resulted in at least eight civilians killed and 52 wounded [3].

This investigation will consider the shelling with the use of Grad MLRS that took place at about 18:00 on 14 July 2014. During that incident, houses in the Mirny and Gaevogo quarters were damaged. A list of the killed persons compiled based on reports from citizens has been published on the Internet [4]. It contains the names of those civilians who died during that incident. The list contains the following names of those died on 14 July 2014:

1. Bakhmach, Nikolay, born [.....], died 14.07.2014
2. Bobyor, Sergey Petrovich, born 11.1958, died 14.07.2014

3. Logachyova, Alla, born 06.1976, died 14.07.2014

Important! Since data is collected anonymously via a self-filled-in form, we cannot guarantee that it is true. If you see the name(s) of any of your beloved one(s), please also check out other sources.

To add information, please use the following link: <http://goo.gl/pk1Qxs>

Date and time of entry	Last, first and middle names	Place of death	Birth date	Approximate birth date (if the exact one is unknown)	Death date	Circumstances of death
08.12.2014 18:46:37	Bakhmach, Nikolay	Lugansk, Mirny quarter			14.07.2014	Killed by a shelling of Mirny while shielding a child
08.12.2014 22:37:24	Bobyor, Sergey Petrovich	Lugansk, Mirny quarter, near house 2	09.11.1958		14.07.2014	Killed <i>en route</i> from the bus stop (Mirny Ring) to his house No. 1 on Mirny at 50 metres from the entrance. Two metal splinters were later taken from his body. Died from blood loss. Had not used his car for two weeks. Entered by his son, Alexey Bobyor
8 12.2014 18:42:10	Logachyova, Alla	Lugansk, Mirny quarter	23.06.1976		14.07.2014	Killed by a shelling of Mirny

Fig. 1. Part of the list of the killed persons published on the Internet [5].

The list contains no information on a young man who was killed at the Vtorchermet bus stop south of the building located at 77 Andreyeva Linyova Street in Lugansk (as depicted on the relevant photo/video).

ACCIDENT SCENE

Having examined the photo and video materials published in the media and on the Internet and reviewed the statements of the witnesses of the shelling of Lugansk that took place at about 18:00 (local time) on 14 July 2014, we have managed to find 14 places hit by artillery shells. It should be noted that we only considered those places for which there is a plenty of information allowing to bring them into correlation with the time and place of the shelling. It is important to note that there were more such places, according to witness statements.

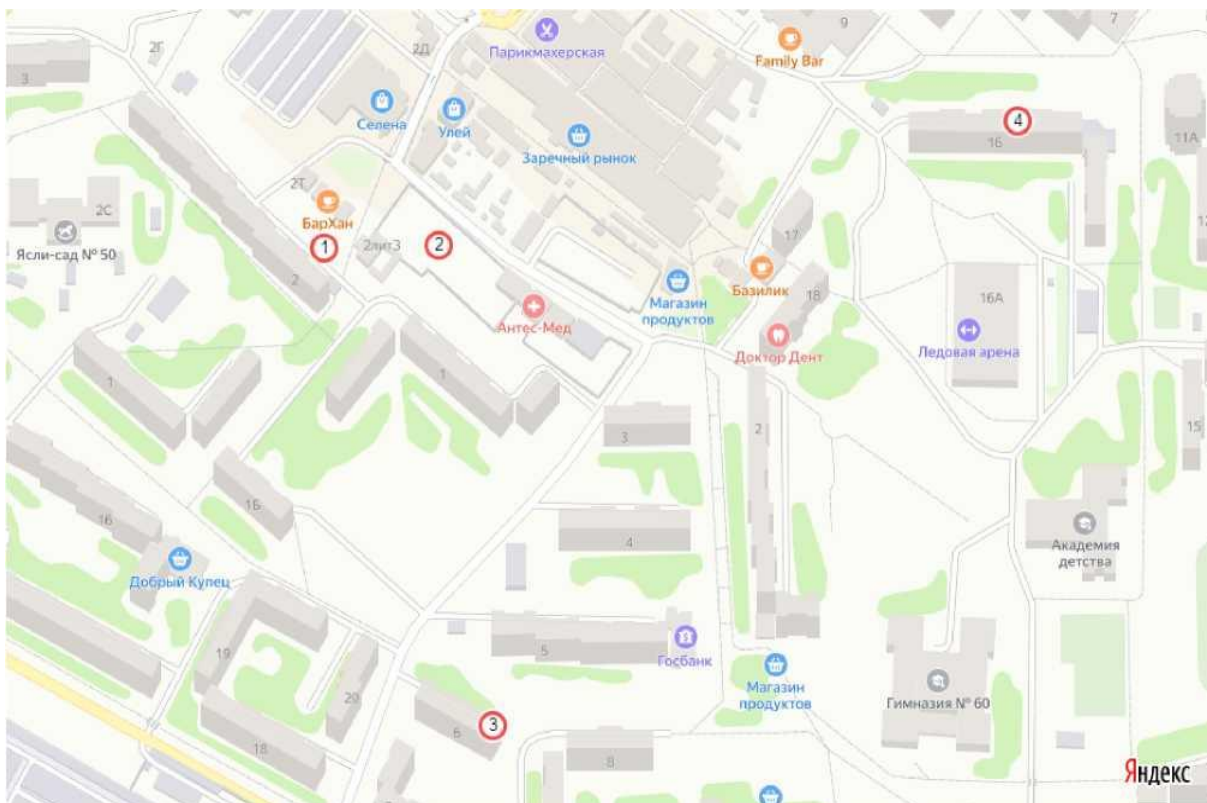

Fig. 2. Scheme of the shelling of the Mirny quarter in Lugansk that took place at about 18:00 (Moscow time) on 14 July 2014.

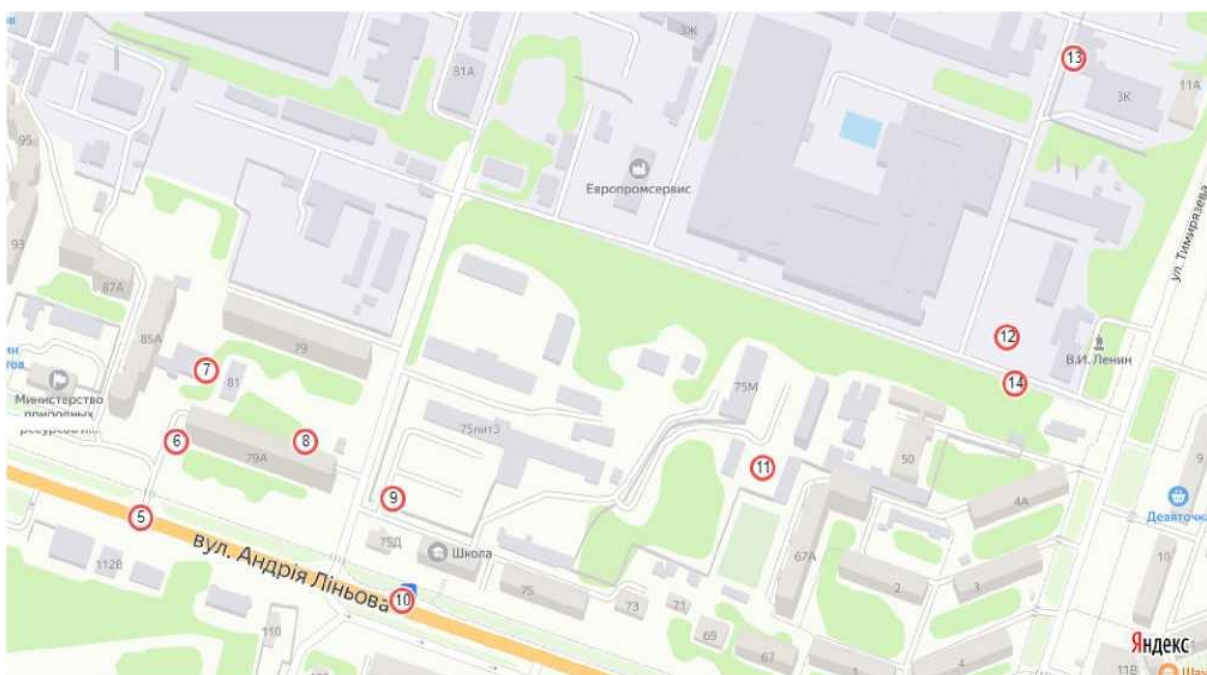

Fig. 3. Scheme of the shelling of the Gaevogo quarter in Lugansk that took place at about 18:00 (Moscow time) on 14 July 2014.

Hit Instance 1. A shell hit the lawn between the building located at 2 Mirny quarter in Lugansk and the “Karefan” café located at 2 Mirny quarter, bldg. 3 in Lugansk. As a result of its detonation, a young mother walking with her child and Nikolay Bakhmach got shrapnel wounds incompatible with life [6].



Fig. 4. The shell that hit the ground between the building located at 2 Mirny quarter and the “Karefan” café [7].



Fig. 5. The body of a man who died near the “Karefan” café [8].

Hit Instance 2. A shell hit the car parking area adjacent to the “Karefan” café from the north. As a result of detonation, several cars were set on fire.



Fig. 6. Burning cars at the parking area adjacent to the “Karefan” café from the north after it was hit by a shell [9].

Hit Instance 3. A shell hit the northern wall of a multi-storey residential building located at 6 Stepnoy quarter in Lugansk at the level of the fifth floor. Its detonation made a hole in the building wall.



Fig. 7. The northern wall of a multi-storey residential building located at 6 Stepnoy quarter hit by a shell at the level of the fifth floor [10].



Fig. 8. The northern wall of a multi-storey residential building located at 6 Stepnoy quarter hit by a shell at the level of the fifth floor [11].

Hit Instance 4. A shell hit the northern wall of a multi-storey residential building located at 16 Olkhovsky quarter in Lugansk at the level of the third floor. Its detonation made a hole in the wall of the building.



Fig. 9. The hole resulting from the detonation of the shell that hit the northern wall of a multi-storey residential building located at 16 Olkhovsky quarter at the level of the third floor [12].



Fig. 10. The hole resulting from the detonation of the shell that hit the northern wall of a multi-storey residential building located at 16 Olkhovsky quarter at the level of the third floor [13].



Fig. 11. A shell fragment found close to the place of detonation near the residential building located at 16 Olkhovsky quarter [14].

Hit Instance 5. A shell hit the road surface at the exit from Andreyva Linyova Street in front of the western end of the building located at 79A Andreyva Linyova Street. Its detonation made a crater on the road.



Fig. 12. Remains of the rocket on the road surface at the exit from Andreyva Linyova Street in front of the western end of the building located at 79A Andreyva Linyova Street [15].

Hit Instance 6. A shell hit the lawn several metres from the south-northern corner of the multi-storey residential building located at 79A Andreyva Linyova Street in Lugansk. Its detonation made a crater on the lawn.



Fig. 13. A crater resulting from the explosion of a shell on the lawn several metres from the south-northern corner of the multi-storey residential building located at 79A Andreyva Linyova Street [16].

Hit Instance 7. A shell hit a sidewalk curbstone between the residential buildings located at 85A Andreyva Linyova Street and 81 Andreyva Linyova Street in Lugansk. Its detonation made a crater on the ground.



Fig. 14. A sidewalk curbstone hit by a shell between the residential buildings located at 85A Andreyva Linyova Street and 81 Andreyva Linyova Street [17].

Hit Instance 8. A shell hit the ground several metres north of the residential building located at 79A Andreyva Linyova Street in Lugansk, between its first and second entrances. Its detonation made a crater on the ground in the yard of the building.



Fig. 15. Remains of the rocket that hit the ground several metres north of the building located at 79A Andreyva Linyova Street, between its first and second entrances [18].



Fig. 16. The crater in the yard of the multi-storey residential building located at 79A Andreyva Linyova Street, between its first and second entrances [19].

Hit Instance 9. A shell hit the northern wall of the two-storey residential building located at 75L Andreyana Linyova Street in Lugansk at the level of the second floor. Its detonation made a hole in the wall of the building.



Fig. 17. The hole resulting from the detonation of the shell that hit the northern wall of the two-storey residential building located at 75L Andreyana Linyova Street at the level of the second floor [20].

Hit Instance 10. A shell hit a curbstone in the northern part of the road near the Vtorchermet bus stop south of the house located at 77 Andreyana Linyova Street in Lugansk. Its detonation killed an unknown man at the bus stop and made a crater in the curbstone.



Fig. 18. The crater resulting from the explosion of the shell that hit the curbstone in the northern part of the road near the Vtorchermet bus stop south of the house located at 77 Andreyva Linyova Street [21].



Fig. 19. The crater resulting from the explosion of the shell that hit the curbstone in the northern part of the road near the Vtorchermet bus stop south of the house located at 77 Andreyva Linyova Street [22].



Fig. 20. The body of the man killed at the Vtorchermet bus stop south of the house located at 77 Andrey Linyova Street [23].

Hit Instance 11. A shell hit the asphalt pavement in a garage area. Its detonation made a crater 45 metres south of the south-eastern corner of the building located at 75M Andrey Linyova Street in Lugansk.



Fig. 21. The crater resulting from the explosion of a shell 45 metres south of the south-eastern corner of the building located at 75M Andrey Linyova Street [24].



Fig. 22. Remains of the rocket in the crater left by explosion of a shell 45 metres south of the south-eastern corner of the building located at 75M Andreyeva Linyova Street [25].

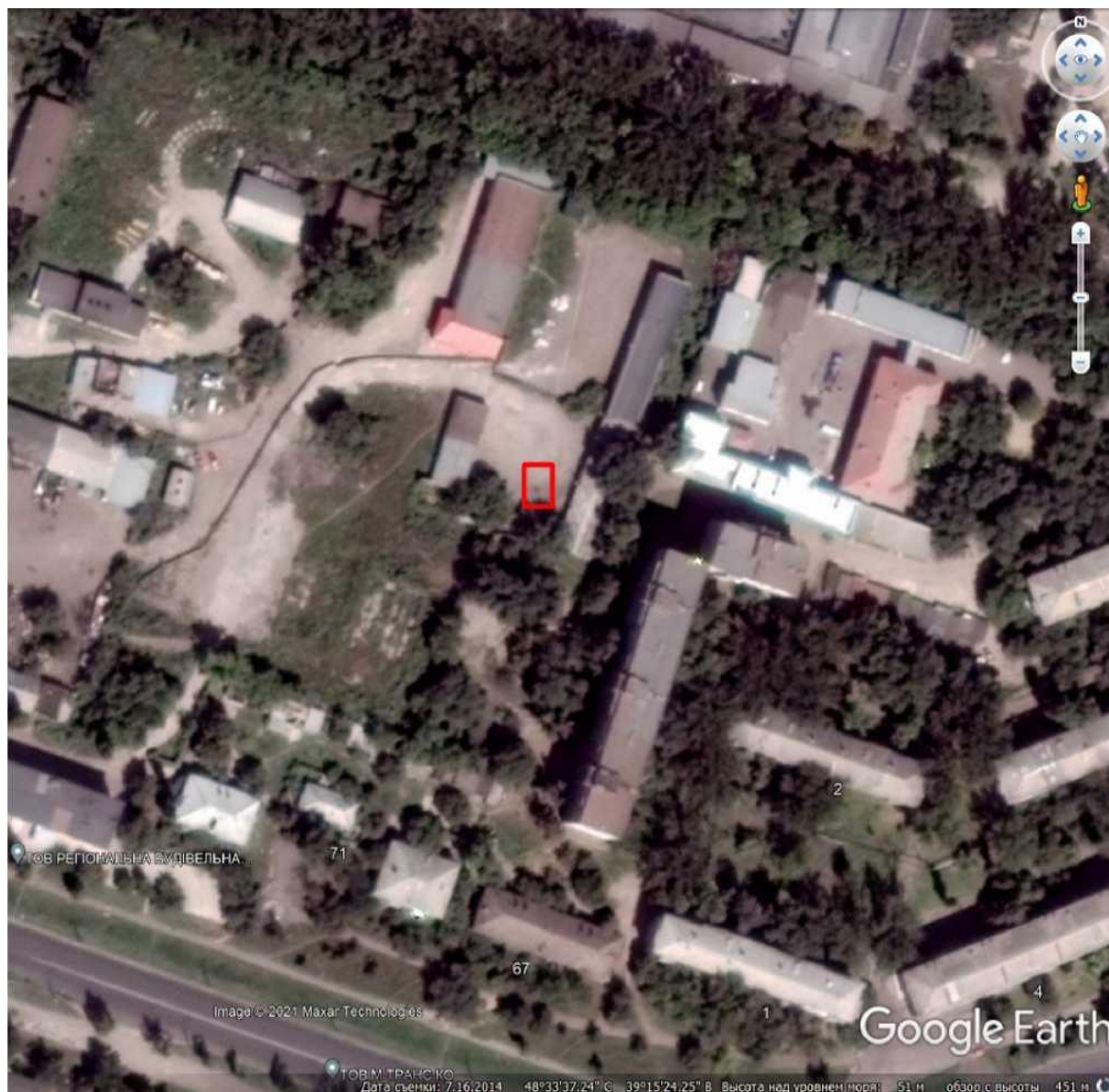

Fig. 23. The crater in the asphalt pavement in the garage area 45 metres south of the south-eastern corner of the building located at 75M Andreyva Linyova Street as seen on a satellite image dated 16 July 2014.

Hit Instance 12. A shell hit the car parking area west of the residential building located at 3G Timiryazeva Street in Lugansk. Its detonation caused a fire.



Fig. 24. The crater made by the shell that hit the car parking area west of the residential building located at 3G Timiryazeva Street [26].



Fig. 25. The crater resulting from explosion of the shell that hit the car parking area west of the residential building located at 3G Timiryazeva Street [27].

Hit Instance 13. A shell hit the roof of the utility structure north of the building located at 75 Andreyva Linyova Street, bldg. 3 in Lugansk. Its detonation made a hole in the roof.



Fig. 26. The hole resulting from the detonation of the shell in the inner wall of the utility structure north of the building located at 75 Andreyva Linyova Street, bldg. 3 [28].



Fig. 27. The hole in the roof resulting from the detonation of the shell that hit the roof of the utility structure north of the building located at 75 Andreyva Linyova Street, bldg. 3 [29].



Fig. 28. The hole in the roof resulting from the detonation of the shell that hit the roof of the utility structure north of the building located at 75 Andreya Linyova Street, bldg. 3 as seen on a satellite image dated 16 July 2014.

Hit Instance 14. A shell hit the road surface approximately 25 metres from the southwest corner of the building located at 3G Timiryazeva Street in Lugansk. Its detonation made a crater on the road.



Fig. 29. The crater resulting from the explosion of a shell approximately 25 metres from the southwest corner of the building located at 3G Timiryazeva Street [30].





Fig. 30. Remains of the rocket found near the crater approximately 25 metres from the southwest corner of the building located at 3G Timiryazeva Street [31].

TYPE OF WEAPONS

Witness Statements and Evidence

In all of the Hit Instances discussed, remains of a MLRS rocket shell were found. In Hit Instances 12 and 13, remains of the rockets having the shape of the fin assembly fastener openings characteristic of a BM-21 Grad MLRS rocket were found [32].



Fig. 31. The shape of the fin assembly fastener openings characteristic of a BM-21 Grad MLRS shell at the site of Hit Instance 12 [33].



Fig. 32. The shape of the fin assembly fastener openings characteristic of a BM-21 Grad MLRS shell at the site of Hit Instance 13 [34].

In addition, Grad MLRS rockets feature seven nozzles in contrast to one nozzle found in Smerch and Uragan MLRS rockets.

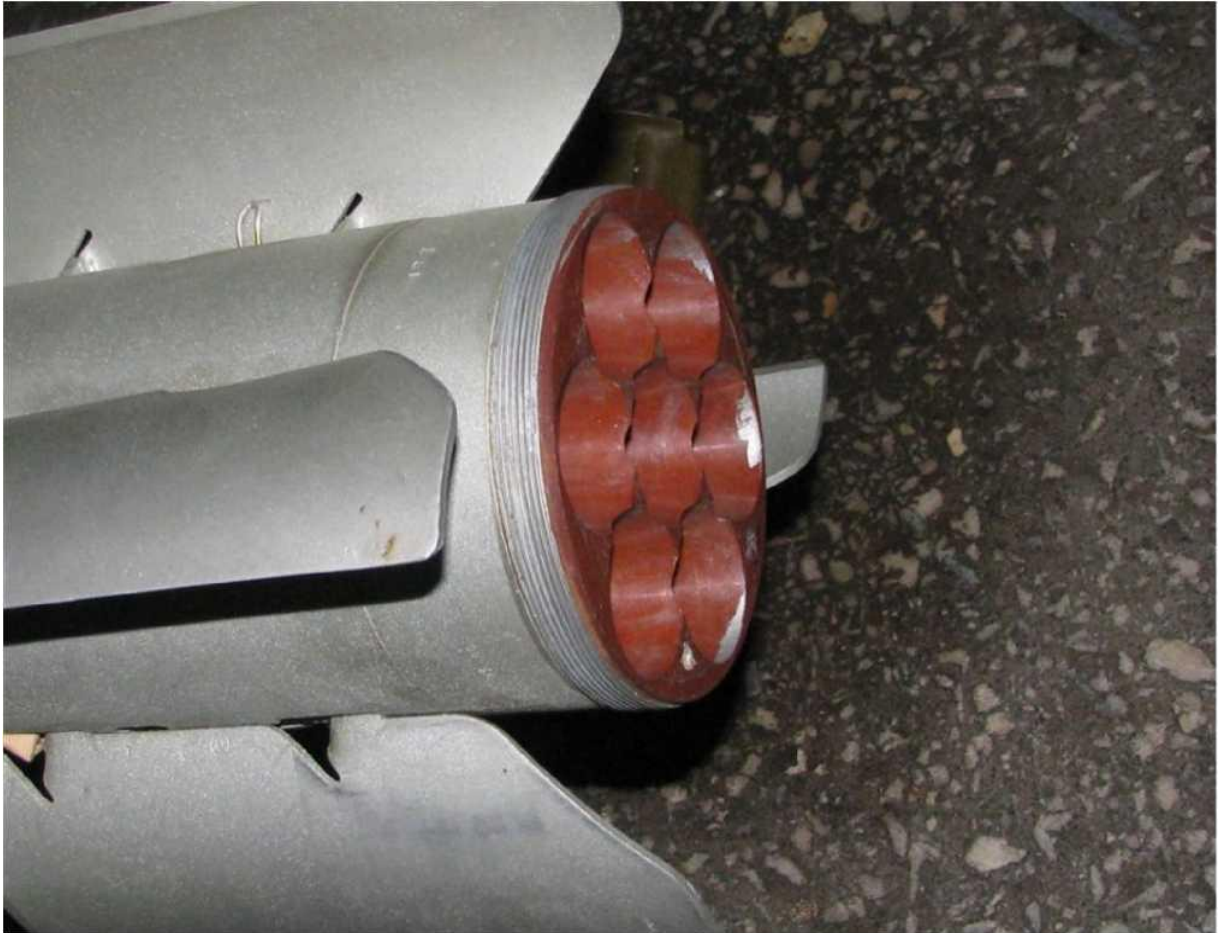

Fig. 33. View of the fin assembly and cut nozzle cluster of a 9M22M unguided dummy rocket [35].



View of the tail assembly (with the nozzle cluster) of an Uragan MLRS 220-mm unguided dummy rocket as exposed in the Military History Museum of Artillery, Engineers and Signal Corps (VIMAIViVS) (St. Petersburg, Russia). Photo: S.V. Gurov (Tula, Russia).

Fig. 34. Cutaway view of the nozzle of the rocket of an Uragan MLRS shell [36].



View of the tail assembly (with the nozzle cluster) of a Smerch MLRS 300-mm unguided dummy rocket as exposed in the Military History Museum of Artillery, Engineers and Signal Corps (VIMAIViVS) (St. Petersburg, Russia). Photo: S.V. Gurov (Tula, Russia).

Fig. 35. Cutaway view of the nozzle of the rocket of a Smerch MLRS shell [37].

Remains of the rocket shells featuring characteristic seven nozzles were found at the sites of Hit Instances 13 and 14.





Fig. 30. Remains of the rocket shell found near the crater approximately 25 metres from the southwest corner of the building located at 3G Timiryazeva Street [38].

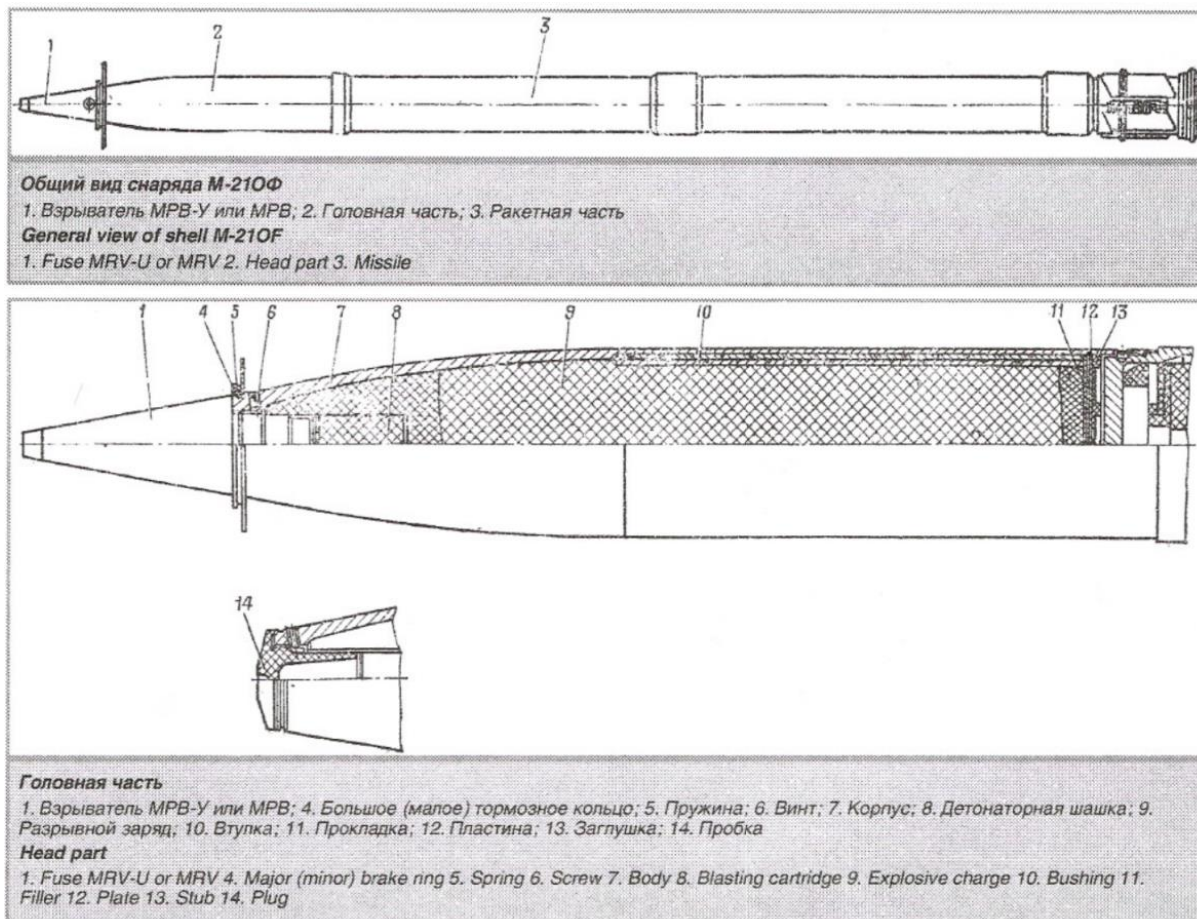

Fig. 31. The shape of the fin fastener openings characteristic of BM-21 Grad shells at the site of Hit Instance 12 [39].

The above evidence provides a good reason for us to assert that the shelling was carried out with the use of a BM-21 Grad MLRS.

BM-21 Grad MLRS

A BM-21 Grad MLRS shell consists of a fuse, a head, and a rocket. When the shell hits an obstacle, the fuse initiates an explosion of the head which blows in pieces. The rocket remains more or less intact yet deformed. It is usually found either inside or in the immediate vicinity of the crater. For clarity, the design and technical characteristics of the shell most commonly used for firing from a 9K51 Grad MLRS are shown below.



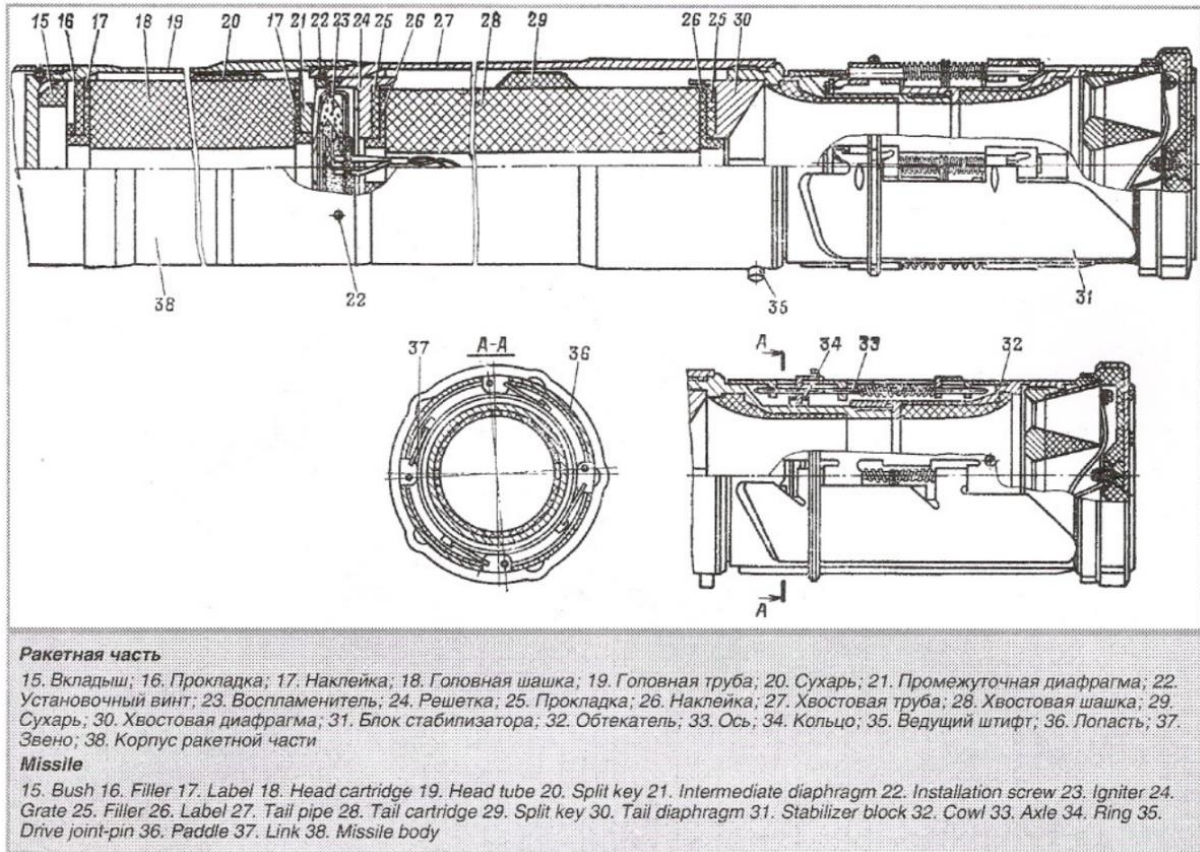

Fig. 36. Design of a M-21OF high-explosive fragmentation shell used for firing from a 9K51 Grad MLRS [40].

PROBABLE SECTOR OF FIRE

Direction

Hit Instance 4 occurred in the northern wall of the building. The damage caused to the wall by the shell fragments shows that the intersection of the plane of the wall and that the plane of the fragmentation pattern formed an almost horizontal line. Therefore, the shell flew almost square to the wall. Given the fact that House No. 16 in the Olkhovsky quarter is oriented strictly to the north, we may assert that the shell flew from the north to the south.



Fig. 38. Fragmentation pattern (Hit Instance 4) [41].

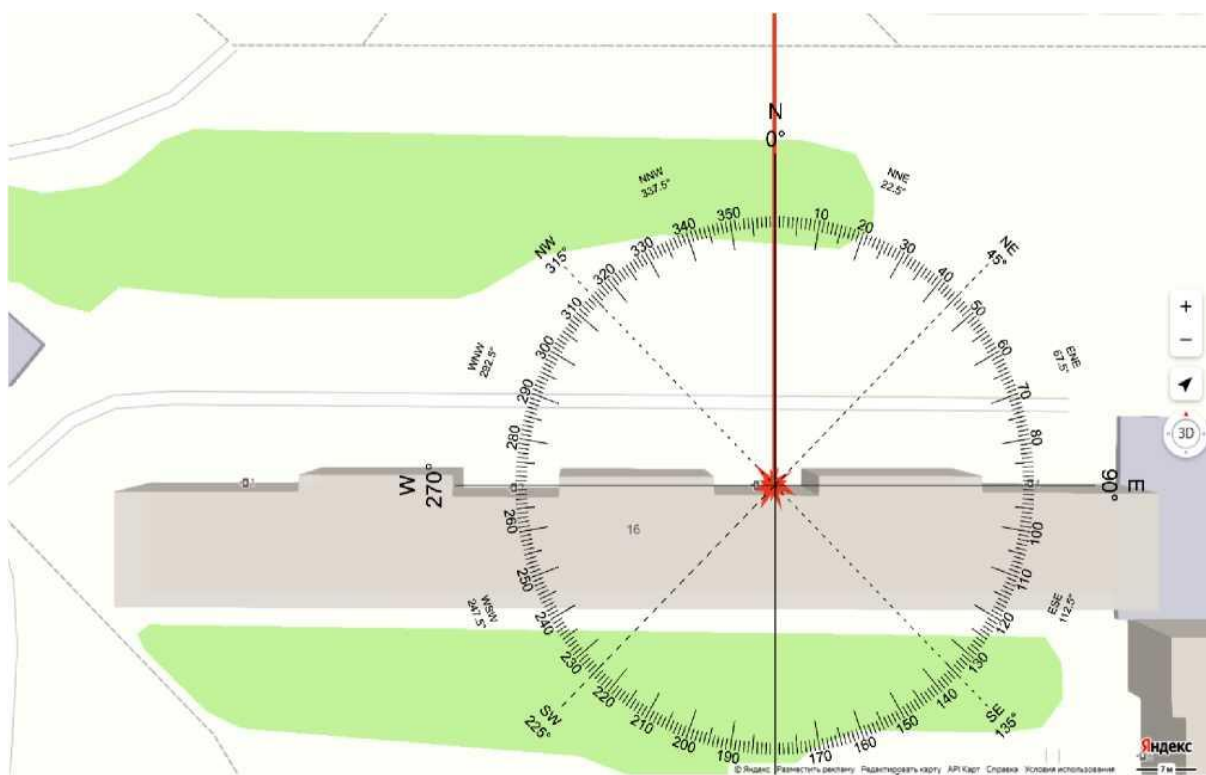

Fig. 39. Fire direction for Hit Instance 4.

Hit Instance 13 has a distinct shape of a crater resulting from the explosion of a shell contacting the surface at a small striking angle without any delay of detonation. Such craters usually have a shape pointing to the gun.

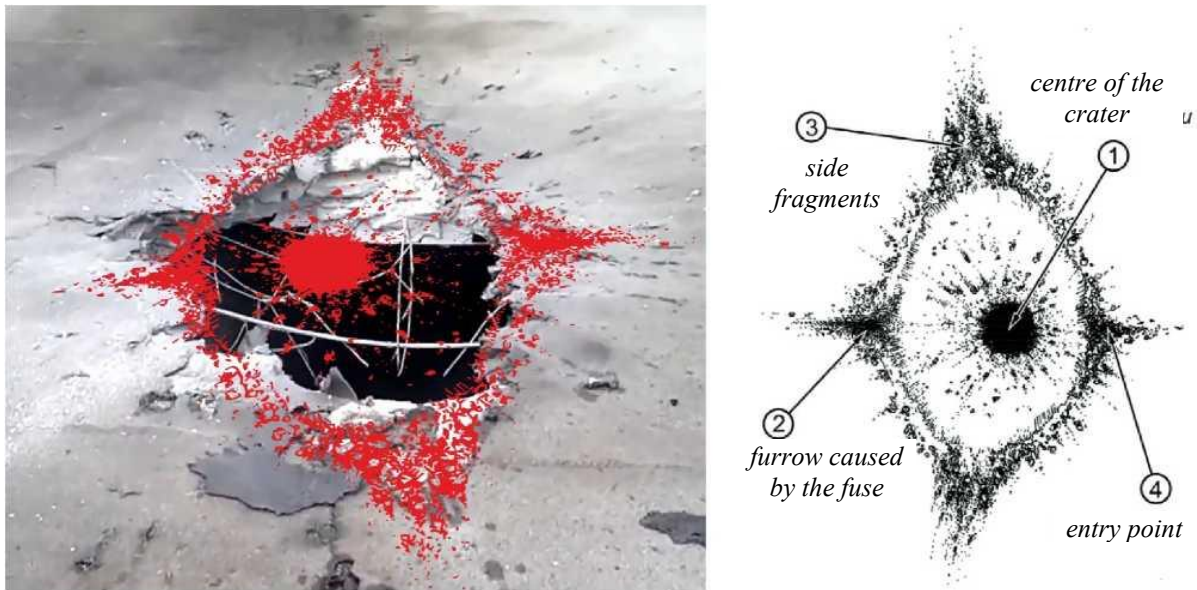

Fig. 40. The distinct shape of the crater in Hit Instance 13 [42].

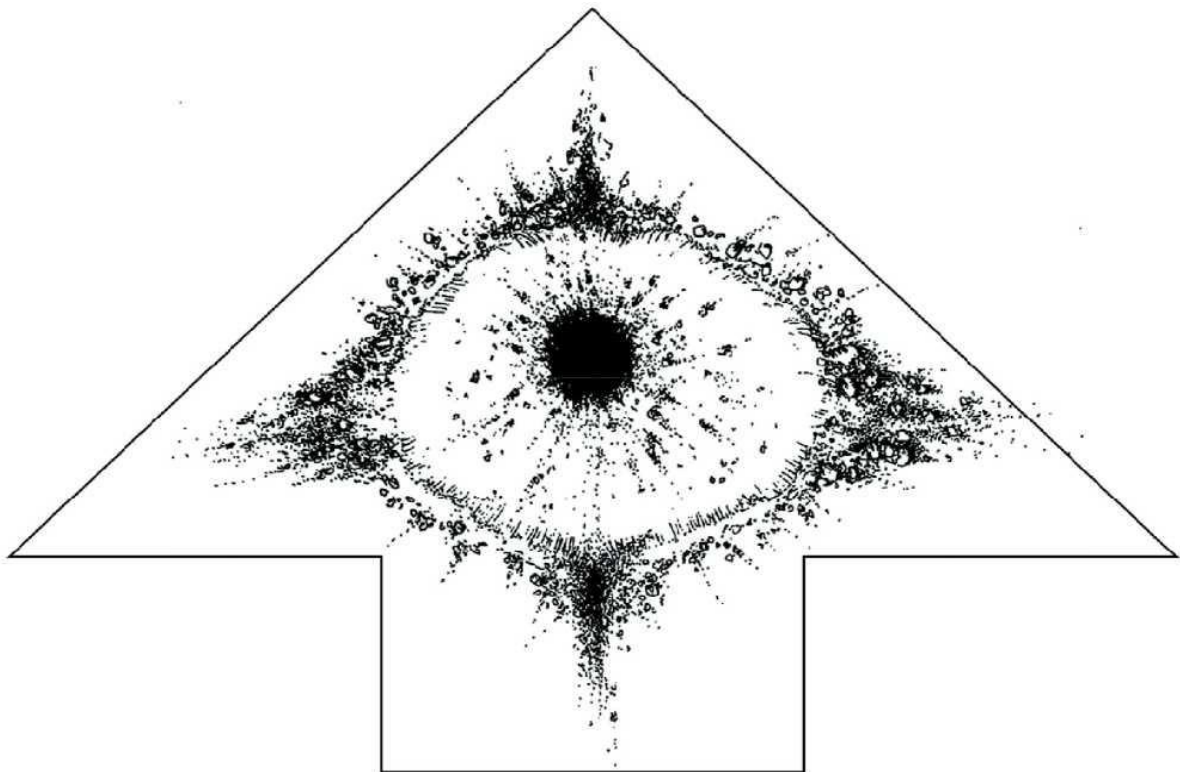

Fig. 41. The shape of the crater resulting from the explosion of a shell contacting the surface at a small striking angle without any delay of detonation allows us to determine the direction of fire [43].

This hit instance is clearly seen on a satellite image and allows us to determine the direction of fire. As in the previous instance, the fire direction was from the north to the south.



Fig. 42. Determining the direction of fire on a satellite image dated 16 July 2014 (Hit Instance 13).

It should also be noted that the northern wall of the building located at 75L Andreyeva Linyova Street was damaged in Hit Instance 9, while Hit Instance 8 occurred near the northern wall of the building located at 79A Andreyeva Linyova Street.

Furthermore, in Hit Instance 10, the shell fragments are traced predominantly on the northern side of the curbstone hit by the shell, which indicates that the direction of fire was from the north to the south.



Fig. 43. Hit Instance 10: Shell fragments are traced predominantly on the northern side of the curbstone [44].

Given the fact that, according to witness statements, all of the Hit Instances took place simultaneously and, as we will show below, with the use of one type of artillery gun, we can assert that all shells flew in the direction from the north to the south.

Sector of Fire

The firing distance of a BM-21 Grad MLRS using the most common types of unguided high-explosive fragmentation shells ranges from 5 km to 20.4 km [45].

Besides, a detailed description of the current situation at the line of contact can be found in social networks [46]. An operation battle map for 13 June 2014 and 14 June 2014 is also available there.

Important! Since data is collected anonymously via a self-filled-in form, we cannot guarantee that it is true. If you see the name(s) of any of your beloved one(s), please also check out other sources.

To add information, please use the following link: <http://goo.gl/pk1Qxs>

Date and time of entry	Last, first and middle names	Place of death	Birth date	Approximate birth date (if the exact one is unknown)	Death date	Circumstances of death
08.12.2014 18:46:37	Bakhmach, Nikolay	Lugansk, Mirny quarter			14.07.2014	Killed by a shelling of Mirny while shielding a child
08.16.2014 22:37:24	Bobyor, Sergey Petrovich	Lugansk, Mirny quarter, near house 2	09.11.1958		14.07.2014	Killed <i>en route</i> from the bus stop (Mirny Ring) to his house No. 1 on Mirny at 50 metres from the entrance. Two metal splinters were later taken from his body. Died from blood loss. Had not used his car for two weeks. Entered by his son, Alexey Bobyor
8 12.2014 18:42:10	Logachyova, Alla	Lugansk, Mirny quarter	23.06.1976		14.07.2014	Killed by a shelling of Mirny

Fig. 1. Part of the list of the killed persons published on the Internet [47].

By plotting on the map a sector showing the minimum and maximum firing distances, the azimuth of the direction of fire with an accuracy of plus or minus 15 degrees, and the demarcation line, we will get a visual representation of the area from which the shelling of Lugansk was carried out on 14 July 2014.

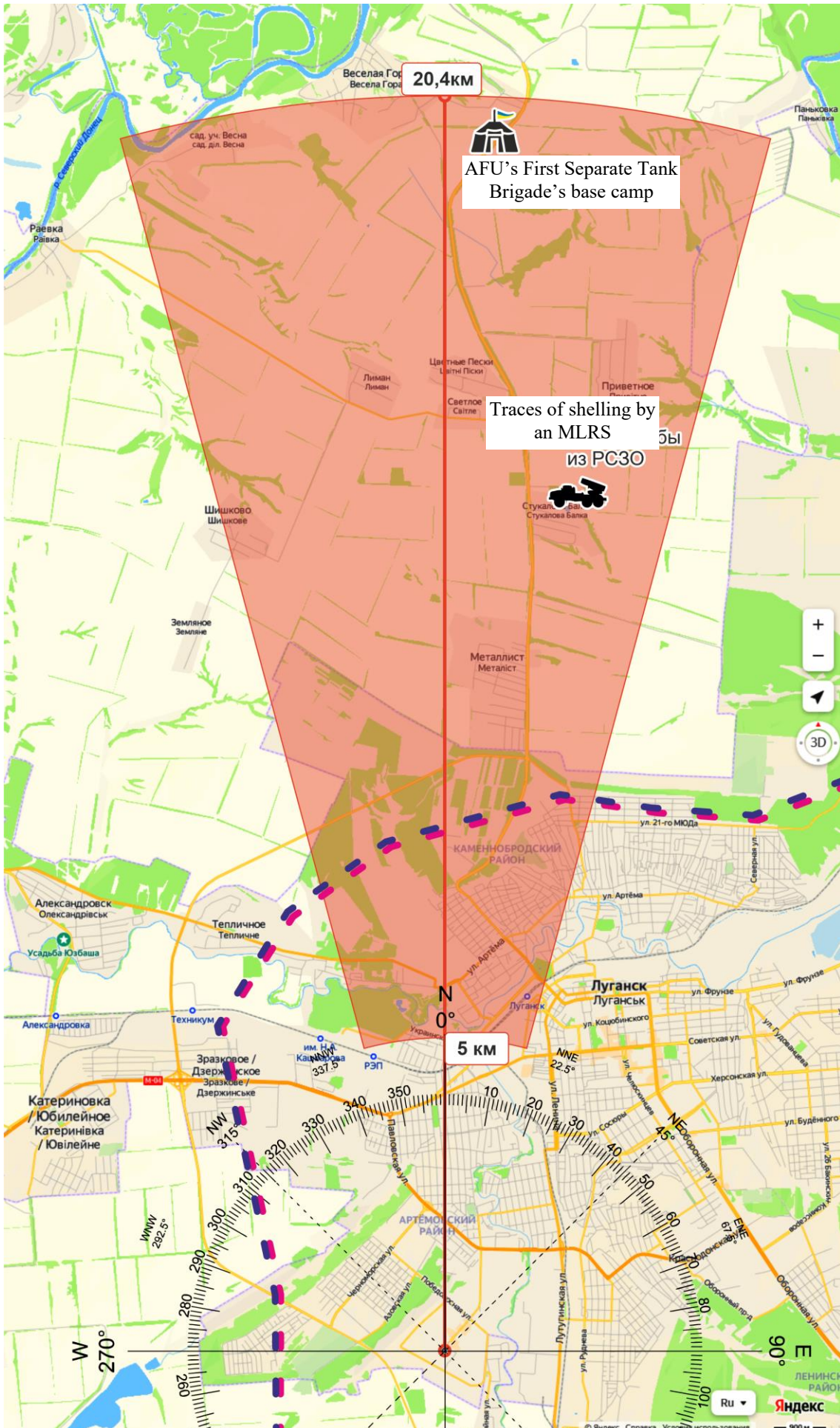



This sector has the shape of a truncated triangle with the following corners: the Vesna garden plots – the village of Pankovka – Artyomovskyy District of Lugansk – the intersection of Kirova Street, Andrey Linyova Street and Ukrainskaya Street in Lugansk. The sector goes deep into the territory controlled by the LPR’s armed formations for about three kilometres. At the same time, it should be noted that a Grade MLRS is usually placed at least three to four kilometres away from the active combat zone (to avoid the risk to the valuable equipment). Therefore, our primary attention should be drawn to that part of the sector lying north of the village of Metallist.

PRESENCE OF ARMED FORMATIONS

Armed Formations Present in the Sector

On 19 August 2014, Hromadske TV showed a video titled “Lugansk under Siege. Vesela Hora” (in Ukrainian) [48]. As follows from the subtitles, the video was filmed on 18 August 2014.

The video featured military personnel of the Sivversk First Separate Tank Brigade (First STB) of the Armed Forces of Ukraine (AFU). At the second minute of the video, a military man named Dmitry says they have been on the frontlines for more than a month. Therefore, we can assert that a base camp of the AFU’s First STB was situated in the area of Vesela Hora on 14 July 2014. Moreover, that base camp is clearly seen on a satellite image dated 17 July 2014.

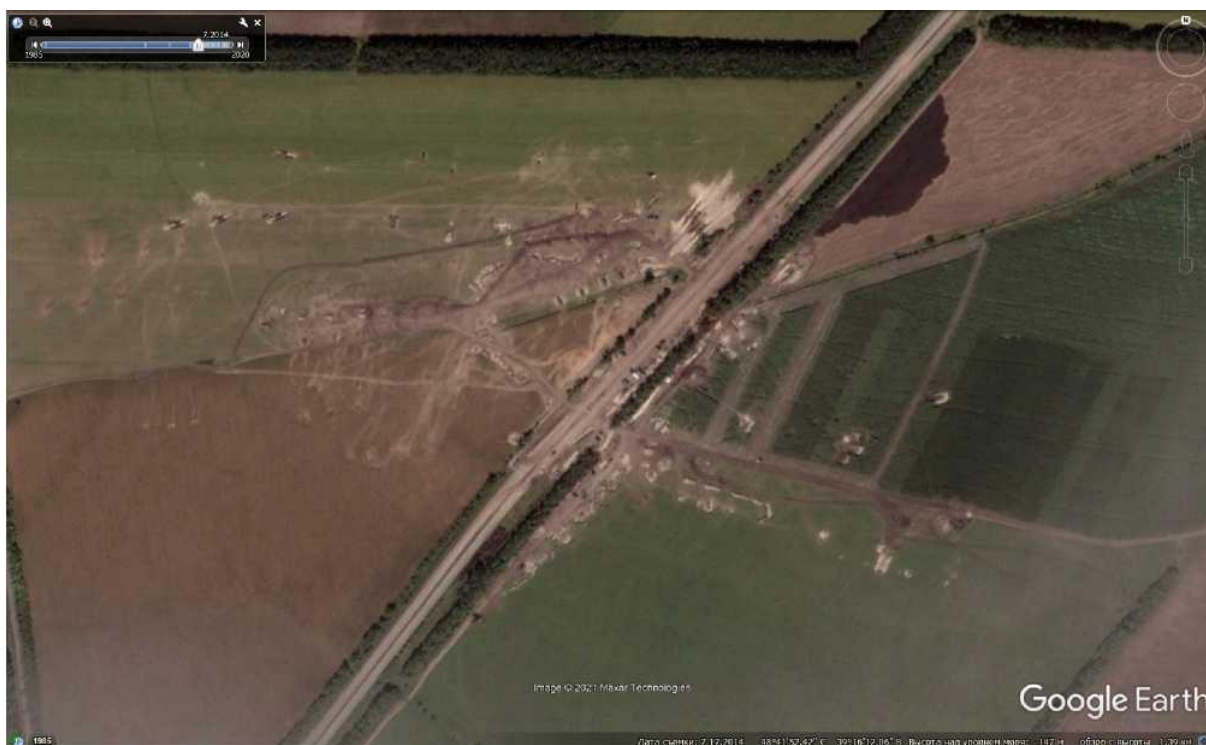

Fig. 46. Base camp of the AFU’s First STB near Vesela Hora as seen on a satellite image dated 17 July 2014.

According to the Ukrainian Wikipedia, the brigade has a rocket artillery battalion [49]. That is also confirmed by the above video featuring three Ukrainian BM-21 Grad MLRS units appearing in the frame at the seventh minute, firing shells to Lugansk from their combat positions. From the further viewing of the video, it becomes clear that these MLRS units belonged to the First STB.



Fig. 47. Ukrainian BM-21 Grad MLRS units shelling Lugansk from their positions near Vesela Hora.

In addition, a satellite image dated 17 July 2014 shows three burnt ground spots not far from Stukalova Balka. These spots are very similar to the traces left by a launch of MLRS rockets. Tracks of vehicles moving towards those spots are also seen on the ground to the north of them.



Fig. 48. Burnt ground spots and tracks of vehicles moving towards those spots from the north of Stukalova Balka (as seen on a satellite image dated 17 July 2014).

We can assume that a battery of Grad MLRS units was put forward from the base camp near Vesela Hora to take positions near Stukalova Balka to support the attack on the Lugansk airport.

Therefore, we can assume that a rocket artillery battalion of the First STB was located in the sector from which BM-21 Grad MLRS rockets were fired at Lugansk on 14 July 2014.

Siversk First Separate Brigade (Ukraine)

The Siversk First Separate Brigade (First STB) was formed in 1997 in the settlement of Honcharivske as a successor to the 92nd Guards Tank Regiment of the 72nd Mechanised Division. It was awarded the honorary name “Siversk”.

1-ша окрема танкова бригада
(з 1997)

292-й танковий полк
(1992—1997)



LOSTARMOUR
☰

Нарукавний знак бригади з 2019 р.

Засновано	1992
Країна	 Україна
Вид	 Сухопутні війська
Тип	 Танкові війська
Чисельність	бригада
У складі	 ОК «Північ»
Базування	 Чернігівська область с/мт Гончарівське
Війни/битви	Російська збройна агресія проти України <ul style="list-style-type: none"> • Війна на сході України <ul style="list-style-type: none"> • Луганський аеропорт • Донецький аеропорт • Бої за Піски • Бої за Дебальцеве
Почесні найменування	Сіверська

Fig. 49. Brief information on the AFU's First STB as contained on the Ukrainian Wikipedia website [50].

As of the beginning of 2014, the First STB had all three battalions it is authorised to have, namely, the first and third ones using T-64B Bulat tanks and the second one using T-64B, T-64BM2 and T-64BV tanks – 125 tanks in total, including 82 relatively new Bulat tanks. In addition, it had a lot (several company kits) of off-line tanks collected from disbanded formations (including at least those from the 128th Separate Mountain Infantry Brigade).

By the way, that enabled the AFU to form two separate tank battalions as part of the 169th Training Centre and compensate for combat losses during the war in late 2014.

Apart from the tank battalions, the First STB also included a mechanised battalion, a brigade artillery group, an anti-aircraft battalion (two 2S6 Tunguska batteries), and a **rocket battalion** (BM-21 Grad MLRS) [51].

In the spring of 2014, the First STB advanced to the Russian border [52]. By July 2014, it was redeployed to the Lugansk direction. Its first tactical objective was the Lugansk airport. The Brigade provided tank and artillery fire support to the 24th, 30th and 128th Mechanised Brigades, the 80th Air Mobile Brigade, and the Aidar Battalion [53].

Liabile Persons

Colonel Andrey Nikolaevich Gritskov generally commanded the First STB in the period from 2008 to 2015 [54]. It is he who is liable for the behaviour of his subordinates at the front.



Fig. 50. Colonel Andrey Nikolaevich Gritskov, Commander of the First STB, born 1972 [55].

In addition, the above-mentioned video featured several people who may be directly involved in the shelling of Lugansk. These are Lieutenant Chepiga, Commander of the First STB's Control Platoon, and Stanislav and Sergey, servicemen of the First STB. The video also featured some other unnamed persons responsible for maintaining Grad MLRS units.



Fig. 51. Lieutenant Chepiga, Commander of the First STB's Control Platoon.



Fig. 52. Personnel of the First STB involved in the Grad MLRS shelling.

CONCLUSIONS

It follows from the foregoing that the Mirny and Gaevogo microdistricts of Lugansk were shelled by Grad MLRS units at about 18:00 (local time) on 14 July 2014. The shell detonations in those microdistricts killed at least four and wounded dozens of civilians.

The 122-mm rockets were fired in the direction from the north to the south.

Upon reviewing the news videos and other information available on the Internet, we have found that units of the Siversk First Separate Tank Brigade (First STB) of the Armed Forces of Ukraine (AFU) were situated in the sector from which the shelling was carried out on 14 July 2014. The fire was most likely carried out from their positions near Stukalova Balka.

The overall command of the First STB was vested at that time in Colonel Andrey Nikolaevich Gritskov. Lieutenant Chepiga (whose first name is unknown), Commander of the First STB's Control Platoon, and Stanislav and Sergey (whose last names are unknown), servicemen of the First STB, could also be directly involved in the shelling from their positions.

References:

- [1] The AFU's attempt to break through to the Lugansk airport on 13 July 2014 and 14 July 2014 // YouTube; URL: <https://youtu.be/MDETm1SgyYU> (accessed on 29.11.2021).
- [2] Lugansk, 14 July 2014, MLRS Shelling of the City // Antimaydan; URL: https://antimaydan.info/2018/07/lugansk_14_iulya_2014_obstrel_goroda_iz_rszo.html (accessed on 29.11.2021).
- [3] Lest We Forget – How Lugansk Was Shelled in July 2014 // LiveJournal; URL: <https://kot-sapog.livejournal.com/9104932.html> (accessed on 29.11.2021).
Mirny and Gaevogo Blocks Attacked by Grad MLRS in Lugansk. PHOTOS. VIDEOS [published on 15.07.2014] // MigNews; URL: <https://mignews.com.ua/sobitiya/inukraine/3242109.html> (accessed on 29.11.2021).
- [4] List of the Killed Persons // Google Docs; URL: https://docs.google.com/spreadsheets/d/1IWV5AOyexGzrz1xCrP4H_Sj-Nvr3kKyq98CVKRo8XAA/edit#gid=306722867 (accessed on 29.11.2021).
- [5] List of the Killed Persons // Google Docs; URL: https://docs.google.com/spreadsheets/d/1IWV5AOyexGzrz1xCrP4H_Sj-Nvr3kKyq98CVKRo8XAA/edit#gid=306722867 (accessed on 29.11.2021).
- [6] 14 July 2014. LifeNews Report [published on 15.07.2014] // VKontakte; URL: https://vk.com/wall-61706629_55971 (accessed on 29.11.2021).
- [7] Lugansk, 14 July 2014, MLRS Shelling of the City // Antimaydan; URL: https://antimaydan.info/2018/07/lugansk_14_iulya_2014_obstrel_goroda_iz_rszo.html (accessed on 29.11.2021).
- [8] LUGANSK AFTER SHELLING 14.07.2014 (VIDEO) [published on 16.07.2014] // LiveInternet; URL: <https://www.liveinternet.ru/users/natashinka57/post331058644/> (accessed on 29.11.2021).
- [9] 14-15 July 2014 Summary Reports by Strelkov Igor Ivanovich [published on 15.07.2014] // Voyennoye Obozreniye; URL: <https://topwar.ru/54249-svodki-ot-strelkova-igorya-ivanovicha-14-15-iyulya-2014-goda.html> (accessed on 29.11.2021).
- [10] Destroyed Lugansk. Part 4. Southern Quarters. Photos [published on 25.07.2014] // Ukr.Media; URL: <https://ukr.media/ukrain/208023/> (accessed on 29.11.2021).

- [11] 6 Stepnoy Quarter // Wikimapia URL: <https://wikimapia.org/18850502/ru/%D0%A1%D1%82%D0%B5%D0%BF%D0%BD%D0%BE%D0%B9-%D0%BA%D0%B2%D0%B0%D1%80%D1%82%D0%B0%D0%BB-6> (accessed on 29.11.2021).
- [12] 16 Olkhovsky Quarter in Lugansk after Shelling [published on 16.07.2014] // Odnoklassniki; URL: <https://ok.ru/video/2331316729> (accessed on 29.11.2021).
- [13] 16 Olkhovsky Quarter in Lugansk after Shelling [published on 16.07.2014] // Odnoklassniki; URL: <https://ok.ru/video/2331316729> (accessed on 29.11.2021).
- [14] 16 Olkhovsky Quarter in Lugansk after Shelling [published on 16.07.2014] // Odnoklassniki; URL: <https://ok.ru/video/2331316729> (accessed on 29.11.2021).
- [15] Shelling of the Gaevogo Quarter in Lugansk by the Ukrainian National Guard on 14 July 2014 [published on 15.07.2014] // YouTube; URL: <https://youtu.be/V9nDgg4vbMM> (accessed on 29.11.2021).
- [16] Shelling of the Gaevogo Quarter in Lugansk by the Ukrainian National Guard on 14 July 2014 [published on 15.07.2014] // YouTube; URL: <https://youtu.be/V9nDgg4vbMM> (accessed on 29.11.2021).
- [17] Grad Shelling of Linyova Street in Lugansk on 14 July 2014 (Results) [published on 10.10.2014] // VKontakte; URL: https://vk.com/video7456796_170241910 (accessed on 29.11.2021).
- [18] Shelling of Vtorchermet in Lugansk on the 14th of July 18+ [published on 15.07.2014] // VKontakte; URL: https://vk.com/wall-61706629_57777 (accessed on 29.11.2021).
- [19] Shelling of Vtorchermet in Lugansk on the 14th of July 18+ [published on 15.07.2014] // VKontakte; URL: https://vk.com/wall-61706629_57777 (accessed on 29.11.2021).
- [20] Shelling of Vtorchermet in Lugansk on the 14th of July 18+ [published on 15.07.2014] // VKontakte; URL: https://vk.com/wall-61706629_57777 (accessed on 29.11.2021).
- [21] Shelling of Vtorchermet in Lugansk on the 14th of July 18+ [published on 15.07.2014] // VKontakte; URL: https://vk.com/wall-61706629_57777 (accessed on 29.11.2021).
- [22] #Lugansk. House of the Nature (between Selkhoz and the Gaevogo Quarter) [published on 14.07.2014] // VKontakte; URL: https://vk.com/wall-61706629?day=14072014&w=wall-61706629_54059 (accessed on 29.11.2021).
- [23] #Lugansk. House of the Nature (between Selkhoz and the Gaevogo Quarter) [published on 14.07.2014] // VKontakte; URL: https://vk.com/wall-61706629?day=14072014&w=wall-61706629_54059 (accessed on 29.11.2021).
- [24] Shelling of Vtorchermet in Lugansk on the 14th of July 18+ [published on 15.07.2014] // VKontakte; URL: https://vk.com/wall-61706629_57777 (accessed on 29.11.2021).

- [25] Shelling of Vtorchermet in Lugansk on the 14th of July 18+ [published on 15.07.2014] // VKontakte; URL: https://vk.com/wall-61706629_57777 (accessed on 29.11.2021).
- [26] Shelling of Lugansk on 14 July 2014 [published on 17.07.2014] // YouTube; URL: <https://youtu.be/4Xfm0453iVc> (accessed on 29.11.2021).
- [27] Shelling of Lugansk on 14 July 2014 [published on 17.07.2014] // YouTube; URL: <https://youtu.be/4Xfm0453iVc> (accessed on 29.11.2021).
- [28] Shelling of Lugansk on 14 July 2014 [published on 17.07.2014] // YouTube; URL: <https://youtu.be/4Xfm0453iVc> (accessed on 29.11.2021).
- [29] Shelling of Lugansk on 14 July 2014 [published on 17.07.2014] // YouTube; URL: <https://youtu.be/4Xfm0453iVc> (accessed on 29.11.2021).
- [30] Gaevogo Quarter, 14 July 2014. #Lugansk [published on 14.07.2014] // VKontakte; URL: https://vk.com/wall-61706629_54204 (accessed on 29.11.2021).
- [31] Gaevogo Quarter, 14 July 2014 [published on 15.07.2014] // VKontakte; URL: https://vk.com/wall-61706629?day=16072014&w=wall-61706629_56550 (accessed on 29.11.2021).
- Shelling of Vtorchermet in Lugansk on the 14th of July 18+ [published on 15.07.2014] // VKontakte; URL: https://vk.com/wall-61706629?day=16072014&w=wall-61706629_57777 (accessed on 29.11.2021).
- [32] Please see a detailed description of the characteristic shape of BM-21 Grad MLRS missile fin fasteners in the investigation “Shelling of the Town of Makiivka with the Use of BM-21 Grad MLRS Units on 19 August 2014”; URL: <https://lostarmour.info/articles/obstrel-goroda-makeevka-s-primeneniem-sistem-zalпового-огnya-bm-21-grad-19-avgusta-2014-goda/>
- [33] Shelling of Lugansk on 14 July 2014 [published on 17.07.2014] // YouTube; URL: <https://youtu.be/4Xfm0453iVc> (accessed on 29.11.2021).
- [34] Shelling of Lugansk on 14 July 2014 [published on 17.07.2014] // YouTube; URL: <https://youtu.be/4Xfm0453iVc> (accessed on 29.11.2021).
- [35] Missilery as Exposed in the Military History Museum of Artillery, Engineers and Signal Corps (VIMAIViVS) (St. Petersburg, Russia). Part III. // Missilery; URL: <https://missilery.info/gallery/raketnaya-tehnika-v-ekspozicii-voenno-istoricheskogo-muzeya-artillerii-inzhenernyh-voysk-i-1> (accessed on 29.11.2021).
- [36] Rocket Artillery Ammunition // Missilery; URL: <https://missilery.info/article/ram> (accessed on 29.11.2021).
- [37] Rocket Artillery Ammunition // Missilery; URL: <https://missilery.info/article/ram> (accessed on 29.11.2021).

- [38] Gaevogo Quarter, 14 July 2014 [published on 15.07.2014] // VKontakte; URL: https://vk.com/wall-61706629?day=16072014&w=wall-61706629_56550 (accessed on 29.11.2021).
Shelling of Vtorchermet in Lugansk on the 14th of July 18+ [published on 15.07.2014] // VKontakte; URL: https://vk.com/wall-61706629_57777 (accessed on 29.11.2021).
- [39] Shelling of Lugansk on 14 July 2014 [published on 17.07.2014] // YouTube; URL: <https://youtu.be/4Xfm0453iVc> (accessed on 29.11.2021).
- [40] Gun in Russia: BM-21 Grad // Russian Motor Books 2002, 37 pages.
- [41] 16 Olkhovsky Quarter in Lugansk after Shelling [published on 16.07.2014] // Odnoklassniki; URL: <https://ok.ru/video/2331316729> (accessed on 29.11.2021).
- [42] Shelling of Lugansk on 14 July 2014 [published on 17.07.2014] // YouTube; URL: <https://youtu.be/4Xfm0453iVc> (accessed on 29.11.2021).
- [43] Examination of Craters Resulting from Hits of High-Explosive Fragmentation Shells // Justified Protection Social Organisation; URL: <https://oosz.su/node/42> (accessed on 27.11.2021).
- [44] Shelling of Vtorchermet in Lugansk on the 14th of July 18+ [published on 15.07.2014] // VKontakte; URL: https://vk.com/wall-61706629_57777 (accessed on 29.11.2021).
- [45] Grad MLRS: History and Performance Characteristics // Gunsfriend; URL: <https://gunsfriend.ru/rszo-grad-bm-21-tehniceskie-harakteristiki-tth-opisanie-i-istoria-sozdania-reaktivnoj-sistemy-zalpovogo-ogna-dalnost-ustanvki/> (accessed on 29.11.2021).
- [46] Grad MLRS: History and Performance Characteristics // LiveJournal; URL: <https://sobolev-sv.livejournal.com/535544.html> (accessed on 29.11.2021).
- [47] List of the Killed Persons // Google Docs; URL: https://docs.google.com/spreadsheets/d/1IWV5AOyexGzrz1xCrP4H_Sj-Nvr3kKyq98CVKR08XAA/edit#gid=306722867 (accessed on 29.11.2021).
- [48] Lugansk under Siege. Vesela Hora [published on 19.08.2014] // YouTube; URL: <https://youtu.be/uuVS4gkq5tE> (accessed on 29.11.2021).
- [49] First Separate Tank Brigade (Ukraine) // Wikipedia; URL: [https://uk.wikipedia.org/wiki/1-ша_окрема_танкова_бригада_\(Україна\)#cite_note-8](https://uk.wikipedia.org/wiki/1-ша_окрема_танкова_бригада_(Україна)#cite_note-8) (accessed on 29.11.2021).
- [50] First Separate Tank Brigade (Ukraine) // Wikipedia; URL: [https://uk.wikipedia.org/wiki/1-ша_окрема_танкова_бригада_\(Україна\)#cite_note-8](https://uk.wikipedia.org/wiki/1-ша_окрема_танкова_бригада_(Україна)#cite_note-8) (accessed on 29.11.2021).
- [51] News from the Donetsk Region (Donbass) and Ukraine, 11 February 2017.

Annex 44

LiveJournal, *Lest We Forget – How Lugansk Was Shelled in July 2014* (15 July 2018)

(translation)

Translation

LiveJournal, *Lest We Forget – How Lugansk Was Shelled in July 2014* (15 July 2018), available at: <https://kot-sapog.livejournal.com/9104932.html>.

Lest We Forget – How Lugansk Was Shelled in July 2014

15 July 2018 at 12:12 PM

In the evening of 14 July 2014, the Armed Forces of Ukraine (AFU) attacked the Mirny, Gaevogo, Stepnoy and Olkhovsky quarters in Lugansk by using Grad MLRS and artillery systems. The attack killed a mother walking with a baby carriage, bodies of dead people lay on the ground, and a six-year-old child was wounded in the stomach. In total, eight civilians died that day, including one child. 52 people were hospitalised with wounds of varying degrees of severity, including four children.

Annex 45

*MigNews, Mirny and Gaevogo Quarters Attacked by Grad MLRS in Lugansk. PHOTOS.
VIDEOS (15 July 2014)*

(translation)

Translation

MigNews, *Mirny and Gaevogo Quarters Attacked by Grad MLRS in Lugansk. PHOTOS. VIDEOS* (15 July 2014), available at:

<https://web.archive.org/web/20140719045804/https://mignews.com.ua/sobitiya/inukraine/3242109.html>.

MIGNEWS

Mirny and Gaevogo Quarters Attacked by Grad MLRS in Lugansk. PHOTOS. VIDEOS

MIGnews.com.ua

As MIGnews.com.ua previously reported, the Mirny and Gaevogo quarters in Lugansk and the settlement of Roskishne were attacked by a Grad MLRS on 14 July 2014.

According to eyewitnesses, the rockets were fired from the city. A fire broke out in the parking area and the Korefan café.

Annex 46

VESTI.ru, *Airstrike at Snezhnoye: Militiamen Report Dead Civilians* (15 July 2014)

(translation)

Translation

VESTI.ru, *Airstrike at Snezhnoye: Militiamen Report Dead Civilians (15 July 2014)*, available at: <https://www.vesti.ru/article/1842254>.

VESTI

15 July 2014 at 12:49 PM

Airstrike at Snezhnoye: Militiamen Report Dead Civilians



In the early morning of 15 July 2014, the aircraft of the Armed Forces of Ukraine (AFU) bombed the centre of the town of Snezhnoye in the Donetsk Region. As a result of the air raid, civilians were killed and many wounded. According to preliminary information, the AFU's Su-25 aircraft launched at least six unguided rockets at the city centre.

In the early morning of 15 July, the AFU aircraft bombed the centre of the town of Snezhnoye in the Donetsk Region. As a result of the air raid, civilians were killed and many wounded, Interfax reports.

Initially, with reference to the information provided by the militia, it was reported that ten people had been killed. Later, with reference to the press service of the Donetsk Regional Administration, news agencies reported that four civilians died.

“According to eyewitnesses, about ten civilians were killed and many wounded”, said Konstantin Knyrik, the head of the South-Eastern Front Information Centre.

Militiamen report that the AFU aircraft had bombed the tax service's building and a five-story residential building at 14 Lenina Street. Two entrances were completely destroyed. Under the

rubble, rescuers were looking for a grandmother and her grandson. There are no casualties among the militiamen, the Anna-News agency reports.

According to preliminary information, the AFU's Su-25 aircraft launched at least six unguided rockets at the city centre.

Russkaya Vesna has published photos and videos showing the results of the airstrike at Snezhnoye.



However, according to RIA Novosti, Andrey Lysenko, the speaker of the National Security and Defence Council of Ukraine (NSDC), said he does not know whose aircraft bombed Snezhnoye in the early morning of 15 July 2014.

“Since yesterday, the AFU have not carried out a single sortie, so the morning raid on Snezhnoye is regarded as a provocation. A special investigation has been launched into this matter”, he said at his briefing today.

It is also reported that an air strike was carried out on the Mirny quarter in Lugansk in the evening of 14 July 2014. At least two people were killed: a man and a woman. Some people were also wounded, but the exact number is unknown. Windows were broken in the houses. The Vtorchermet bus stop was shelled.

The situation in Lugansk is stably tense. The National Guard is stationed in small groups in the villages of Belye and Zhyoltoye, trying to encircle the city.

In addition, militiamen report that the pilot of the Su-25 aircraft they shot down yesterday in the Krasnodon District was detained. An investigation is underway.

Another skirmish took place the day before at the Donetsk airport, battles were fought in Karlovka, and Maryinka where an oil workshop was set on fire the day before and was periodically under fire during the night. According to militiamen, Ukrainians used howitzers.

According to the information provided by Vladislav Seleznyov, the speaker of the Anti-Terrorist Operation, two Ukrainian soldiers were killed last night, and eight more injured as a result of the hostilities in the east of the country.

In addition, Dmitry Tymchuk, the arranger of the Information Resistance group, said earlier that two crew members of the An-26 aircraft shot down by militiamen on 14 July 2014 were captured, while the fate of six other crew members is unknown, according to *Ukrainskaya Pravda*.

Militiamen stated the night before that they had five crew members of the downed An-26 transport aircraft in captivity. However, Anatoly Antonov, Deputy Defence Minister of Russia, says the Ministry records that the shelling of Russian border settlements from the Ukrainian territory has intensified. Those incidents continue in the absence of any response from the official Kiev, he told reporters today.

Annex 47

RT, *“Still No Answer”*: Eighth Anniversary of Tragic Shelling of Children Beach in Zugres
(13 August 2022)

(translation)

Translation

RT, “*Still No Answer*”: Eighth Anniversary of Tragic Shelling of Children Beach in Zugres (13 August 2022), available at: <https://russian.rt.com/ussr/article/1036237-zugres-plyaj-ukraina-obstrel-vsuvosem-let>.

RT Investigates War Crimes Committed by Ukrainian Regime

13 August 2022 by RT

“Still No Answer”: Eighth Anniversary of Tragic Shelling of Children Beach in Zugres

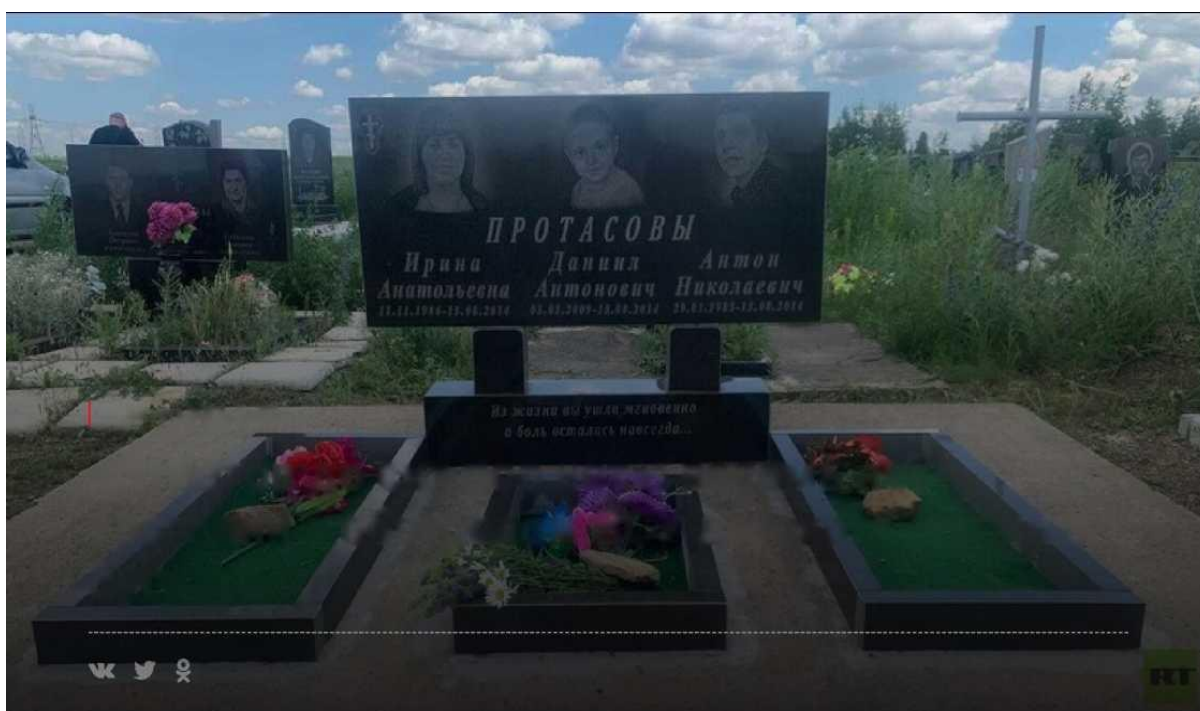

The 13th of August is a special day for the Donetsk People’s Republic (DPR). The local inhabitants recall the shelling of the children beach on the banks of the Krynka river in Zugres. The attack killed 13 civilians, including three children, and wounded more than 30. On the eighth anniversary of the tragedy, RT recollects the circumstances of what happened.

Initially, it was believed that it was the Ukrainian aircraft that struck at Zugres. But the later investigation showed that the shelling of the children beach was carried out by a Smerch MLRS, Vitaly Galakhov, a Donetsk human rights activist and lawyer, told in an interview with RT.

“Eyewitnesses saw a plane. That plane passed over the town and released heat traps. The people thought that the town was fired at by that plane. But when we started collecting photos and videos and interviewed the eyewitnesses, we came to the conclusion that cluster munitions were used,” Mr. Galakhov explained.

Smoke and Screams

Miroslava Zyuzya, a resident of Zugres, shared with RT one of her most poignant memories of the tragedy. On that day, she was relaxing on the children beach with her eight-year-old daughter Polina.

The Armed Forces of Ukraine (AFU) had already bombed the neighbouring towns of Shakhtyorsk and Ilovaisk, Miroslava recalls. But, despite those attacks, no one believed that this was their new reality.

Miroslava went into the water and little Polina was sitting on the river bank when the first shell fell.

“I heard a very sharp sound. Nobody understood anything. Then there was silence. For a while, nothing happened, and then fragments began to fall into the water and onto the beach from above, and the water began to boil around. I remember I thought that I should dive as the fragments could not move so fast in the water,” Miroslava says.

Then there were smoke and screams. Miroslava jumped out of the water and rushed to her daughter. She was terrified of what could happen to the baby. Polina looked unharmed, but only at first glance. A fragment of a Ukrainian mine hit her chest. As turned out later, it went through it, miraculously not affecting the heart and lung. The doctors managed to save the girl.

“It Looked Like a Kind of Joke”

Vitaly Sineok, an employee of the ritual service in Zugres, recalls that the 13th of August was an ordinary summer day with nothing foreshadowing the tragedy. Therefore, he initially mistook the sounds of shell explosions for a salute.

“It seemed like a kind of joke. And then a lot of dust formed on the street. My child was then walking the dog, and I ran through the yards to him. Leaves and branches were falling everywhere. When everything calmed down, the commandant of our town came to me and asked for help in delivering the wounded,” Vitaly recalls.

Dozens of people rushed to the scene of the tragedy to help the victims. According to Vitaly, anyone could stop, take a wounded person and take him or her to the hospital.

“Why did this happen? There is still no answer. And it is still before my eyes how I raised from the sand a child lying next to his father torn by a mine. This memory will stay with me for the rest of my life,” Mr. Sineok says.

The Biggest Grave

Almost the entire town came to the cemetery on the day of the funeral. The grave of the Protasov family was the largest one.

13 August 2014 was the first vacation day of Anton Protasov, a 30-year-old employee of the Zuivska TPP. Together with his wife Irina, they took their five-year-old son Daniel from the kindergarten and went to the town beach. They have not returned home.

When the shelling began, Anton's aunt Tatyana kept calling her nephew and Irina nonstop. She did not want to believe that her relatives were on the beach, but no one answered her phone calls. Then she ran to the scene of the tragedy.

Anton's friends were walking towards Tatyana. She understood everything from their faces. Anton died from multiple wounds, and Irina's artery was broken. When she was falling, she covered her son with herself, so Daniel was still alive for some time. The boy died from a head injury on the way to the hospital.

Anton and Irina were buried in closed coffins as their bodies were severely damaged by the fragments. The burial veil of little Daniel was a little ajar.

Annex 48

TASS, *Ukrainian Shelling Killed at Least 11 in Donetsk* (28 August 2014)

(translation)

Translation

TASS, *Ukrainian Shelling Killed at Least 11 in Donetsk* (28 August 2014), available at: <https://tass.ru/mezhdunarodnaya-panorama/1404809>.

TASS

28 August 2014 at 11:03 AM

Ukrainian Shelling Killed at Least 11 in Donetsk

© Reuters/RUPTLY/TASS TV

The central regional hospital, a school and houses were destroyed

DONETSK, 28 August, by ITAR-TASS. At least 11 people have died as a result of the shelling of Donetsk by Ukrainian troops since yesterday, the residents report. Ten died in a fire in the House of Culture in the city's Kalininsky District. The fire was caused by a projectile. A 23-year-old employee of DTEK repairing TPP lines came under fire and was killed.

The regional clinical hospital – the main medical institution of the city – also suffered from the shelling from a Grad multiple launch rocket system that caused significant damage. The number of the dead and wounded as a result of the shelling is currently being determined.

According to local residents, Ukrainian artillery strikes on various social facilities are usually preceded by reconnaissance drones. Approximately one day before the shelling of the hospital, eyewitnesses observed a drone “hanging” over that area.

Reconnaissance drones were also seen the day before in the Kalininsky District. Donetsk residents fear that the hospital will once again become a target for artillery fire.

Since early morning, Ukrainian aircraft have been patrolling over Donetsk. At 07:00 (Moscow time) and 08:30 (Moscow time), residents of the central districts heard a strong rumble. According to eyewitnesses, the plane dropped a cargo for the Ukrainian troops blocked in the airport area and then flew around the city for reconnaissance purposes.

The residents are now expecting new air strikes.

The shelling of the Petrovsky District continued throughout the night. The civil registration office building and residential buildings on Kirova Street and Leninsky Avenue were destroyed.

The shell hit the roof of School No. 32 causing a fire. The building was burned out beyond repair.

An information war is also being waged against the inhabitants of the city. For example, false messages are spreading on social networks that a shell hit the main filtering station again so that the city will be left without water. Fortunately, that information has not yet been confirmed. However, the water supply has not yet been restored in all districts of the city.

There are communication breakdowns in almost every part of the city.

International bus runs to Russia are now accessible from the Southern Bus Station. In particular, the traffic to Rostov has been resumed.

Annex 49

Letter from the Office of the Prosecutor-General of the Russian Federation No. 82/1-5094-15,
7 February 2017

(translation)

Translation

Letter from the Office of the Prosecutor General of the Russian Federation No. 82/1-5094-15, 7 February 2017.

To: <...>,

Head of International Legal Cooperation and
European Integration Administration,

07.02.2017 82/1-5094-15
14/3-31155-15

Office of the Prosecutor General of Ukraine

Dear <...>,

The Office of the Prosecutor General of the Russian Federation presents its compliments to the Office of the Prosecutor General of Ukraine, and forwards materials obtained in the course of the execution of your request for legal assistance under criminal case #22014000000000266.

At the same time I regret to inform you that it has not been possible to satisfy the above request in terms of identification and questioning as witnesses of A.I. Mozhaev's relatives.

In contradiction to the requirements of Art. 14 (1) (d) of the European Convention on Mutual Assistance in Criminal Matters dated 20.04.1959 and Art.7 (1) (g) of the Convention on Legal Aid and Legal Relations in Civil, Family and Criminal Cases dated 22.01.1993, the request for legal assistance does not indicate first names and surnames of witnesses, their official and actual places of residence, and their places of birth.

Annex: on 3 pages

Yours sincerely

(signature)

Acting Head, Chief Administration
of International Legal Cooperation

<...>

Executed by: <...>
Tel. (495) 982-41-55

(signed) 06.02.17

(signed) 06.02.17

(signed) 07.02.17

(Stamp)

Office of the Prosecutor General of the Russian Federation
#82/1-5094ДСП-2015/НД4109-17

05.08.2016
201-12-2016

To: Head of the Main Informational and
Analytical Centre (MIAC),
RF Ministry of Internal Affairs
Address: 67 Novocheremushkinskaya Street,
Moscow, 117418

In connection with the request for legal assistance from the competent authorities of Ukraine, please forward to our address information on any criminal record or lack thereof of the citizen of the Russian Federation Ravil Zakarievich Khalikov, date of birth 23.02.1969.

Annex: formal request to MIAC MIA RF on 1 page.

Investigator of the investigative group
of the Chief Investigative Administration (signature)
Tel. 8(495) 966-90-47

<...>

From:
Ministry of Internal Affairs
Federal Government Agency “Main
Informational and Analytical Centre of the
Ministry of Internal Affairs of the Russian
Federation (FGA MIAC MIA of Russia)”
Address: 67 Novocheremushkinskaya Street,
Moscow, 117418
Tel. (495) 332-31-77, Fax (495) 667-09-80

To: <...>, Investigator of the investigative
group of the Chief Investigative
Administration
Address: 2 Tekhnicheskij Per., Moscow,
105005

30.08.2016 #34/12/6-204-15
In response to # 201-12-2016 of 05.08.2016

On the provision of information

Your request for information regarding R.Z. Khalikov has been considered.

Hereby we are sending you the formal request with the results of the research of operative and reference records of FGA MIAC MIA of Russia.

Annex: according to above, in 1 copy, on 1 page, to addressee only.

Head of the Operative and Reference Centre,
Colonel of the Internal Service

(signature)

<...>

(Stamp)

Investigative Committee of the Russian Federation
Chief Investigative Administration
6 September 2016

(Stamp)

Investigative Committee of the Russian Federation
Date: 5 September 2016; Time: 10:45
#BXCK-25495-16/

Formal Request

MIAC MIA RF

(name of body to which request is forwarded)

1. **Surname:** Khalikov
2. **Name and patronymic:** Ravil Zakarievich
3. **Date of birth:** 23.02.1969
4. **Place of birth:** Village of Belozerye, Romodanovskiy District, Republic of Mordovia
5. **Address:** not identified
6. **Grounds for search:** request for legal assistance under criminal case No. 22014000000000266.
7. **Requested information:** record of criminal and administrative offences

Senior special investigator,
1st investigative department of the Bureau for Investigation
of Crimes related to the Use of Prohibited Means
and Methods of Warfare, Chief Investigative Administration

Major of Justice (signature) <...>

Sender's address: 2 Tekhnicheskij Per, Moscow, 105005

Name of body: Chief Investigative Administration of the Investigative Committee of the Russian Federation

Recipient's address: 67 Novocheremushkinskaya Street, Moscow, 117418

Note: Formal request must be filled in clearly and legibly; surname, name and patronymic must be written in printed letters in nominative case.

Annex 50

Letter from the Office of the Prosecutor-General of the Russian Federation No. 82/1-5100-15,
20 October 2016

(translation)

Translation

Letter from the Office of the Prosecutor General of the Russian Federation No. 82/1-5100-15, 20 October 2016.

To: <...>

Head of International Legal Cooperation and
European Integration Administration,

20.10.2016 82/1-5100-15
14/3-31158-15

Office of the Prosecutor General of Ukraine

Dear <...>,

The Office of the Prosecutor General of the Russian Federation sends its compliments to the Office of the Prosecutor General of Ukraine, and, in accordance with the European Convention on Mutual Assistance in Criminal Matters dated 20.04.1959 and Art.7 (1), (g) of the Convention on Legal Aid and Legal Relations in Civil, Family and Criminal Cases dated 22.01.1993, hereby forwards materials obtained in the course of the execution of the request of the competent bodies of Ukraine for legal assistance under criminal case #1201400000000283 against I.N. Bezler.

Annex: on 20 pages

Yours sincerely

(signature)

Head, Administration for Legal Assistance, Chief Administration of International Legal
Cooperation <...>

Executed by: <...>

Tel. <...>

(signed) 17.10.16

(signed) 18.10.16

(Stamp)

Office of the Prosecutor General of the Russian Federation
#82/1-5100ДСП-2015/НД37800-16

06.04.2016
201-12-2016

To: <...>,
Head of Address and Information Matters and Information Resources Department,
Office of the Federal Migration Service of Russia for the city of Moscow

Address: 10 Krasnoproletarskaya Street, Moscow, 127994

Dear <...>,

The Chief Investigative Administration of the Investigative Committee of the Russian Federation, in accordance with the requirements of Art. 457 of the Criminal Procedure Code of the Russian Federation, is in the process of fulfilling the request of the competent bodies of Ukraine for legal assistance under criminal case #1201400000000283 initiated in connection with the offences under Art. 258-3, Section 1, Art. 294, Section 1, Art. 258, Section 3, Art. 341, Art. 348, and Art. 349 of the Criminal Code of Ukraine.

In connection with the execution of the said request, pursuant to Art. 21, Section 4 of the Criminal Procedure Code of the Russian Federation, please provide to the Chief Investigative Administration of the Investigative Committee of the Russian Federation information on the official and actual places of residence of Igor Nikolayevich Bezler, d.b. 30.12.1965, born in Simferopol, residing at: Ukraine, Donetsk Oblast, Gorlovka, Ulitsa Rudakova, 33A; Russian passport #1102600442 (no other information about the said person has been provided by the competent bodies of Ukraine).

Please forward properly executed materials obtained in the course of fulfilling this request to the Investigative Committee of the Russian Federation at: 2 Tekhnicheskij Pereulok, Moscow, 105005, Russia.

Taking into consideration that the execution of the request for legal assistance of the competent bodies of Ukraine is under special control of the leadership of the Investigative Committee of the Russian Federation, I urgently ask you to execute it as soon as possible.

Senior investigator, Directorate for Investigation of Crimes related to the Use of Prohibited Means and Methods of Warfare, Chief Investigative Administration, Investigative Committee of the Russian Federation
Major of Justice (signature) <...>

Tel. <...>

(Round seal) (illegible)

(Stamp)
Investigative Committee of the Russian Federation
ref#ck251-10087-16/

From: Administration of the Federal Migration Service of Russia for the city of Moscow (UFMS of Russia for Moscow), Address and Information Matters and Information Resources Department

Address: 10 Krasnoproletarskaya Street, Moscow, 127994
Tel. (499) 978-35-71, fax (499) 978-31-72
<http://www.77.fms.gov.ru>

Date (illegible) 2016 # MC-9-20-3032
In response to: 201-12-2016 of 06.04.2016

On providing information as per request

In response to your request please be informed that, according to the records of UFMS of Russia for Moscow, Igor Nikolayevich Bezler, d.b. 30.12.1965, is not in migration records or registered in Moscow as a place of residence.

There is information in the records that I.N. Bezler received Russian passport ser. 1102 #600442 date of issuance: 12.07.2002, issued by Mirniy GOVD of Arkhangelsk Oblast. As of 20.04.2016 the passport is recorded as "invalid" (reported missing).

To obtain more detailed information on the place of residence of the said person, please contact UFMS of Russia for Arkhangelsk Oblast.

The search was conducted in computerized information systems.

Deputy Head (signature) <...>

(Round seal) (illegible)

(Stamp)
Investigative Committee of the Russian Federation
Chief Investigative Administration
10 May 2016

06.04.2016
201-12-2016

To: Colonel-General <...>,
Service Deputy Head,
Border Control Department Head,
Border Guard,
FSB of Russia

Address: 1 Myasnitskaya Street, Moscow 101000

Dear <...>,

The Chief Investigative Administration of the Investigative Committee of the Russian Federation, in accordance with the requirements of Art. 457 of the Criminal Procedure Code of the Russian Federation, is in the process of fulfilling the request of the competent bodies of Ukraine for legal assistance under criminal case #1201400000000283 initiated in connection with the offences under Art. 258-3, Section 1, Art. 294, Section 1, Art. 258, Section 3, Art. 341, Art. 348, and Art. 349 of the Criminal Code of Ukraine.

In connection with the execution of the said request, pursuant to Art. 21, Section 4 of the Criminal Procedure Code of the Russian Federation, please provide to the Chief Investigative Administration of the Investigative Committee of the Russian Federation information if in the period of from 01.01.2014 till present time the state border of the Russian Federation has been crossed by one Igor Nikolayevich Bezler, d.b. 30.12.1965, born in Simferopol, residing at: Ukraine, Donetsk Oblast, Gorlovka, Ulitsa Rudakova, 33A; Russian passport #1102600442 (no other information about the said person has been provided by the competent bodies of Ukraine). Please forward properly executed materials obtained in the course of fulfilling this request to the Investigative Committee of the Russian Federation at: 2 Tekhnicheskij Pereulok, Moscow, 105005, Russia.

Taking into consideration that the execution of the request for legal assistance of the competent bodies of Ukraine is under special control of the leadership of the Investigative Committee of the Russian Federation, I urgently ask you to execute it as soon as possible.

Senior investigator, Directorate for Investigation of Crimes related to the Use of Prohibited Means and Methods of Warfare, Chief Investigative Administration, Investigative Committee of the Russian Federation

Major of Justice (signature) <...>

Tel. (495) 966-95-10

(Round seal) (illegible)

(Stamp)

Investigative Committee of the Russian Federation
ref#ck251-10091-16/

From:
Federal Security Service of the Russian Federation (FSB of Russia),
BORDER GUARD

26 April 2016 # 21/7/5/2182
Moscow 101000

In response to: #201-12-2016 of 06.04.2016

To:
Major of Justice <...>,
Senior investigator, Directorate for Investigation of Crimes related to the Use of Prohibited
Means and Methods of Warfare, Chief Investigative Administration, Investigative Committee of
the Russian Federation

Address: 2 Tekhnicheskij Per., Moscow 105005

Your request with regard to I.N. Bezler has been considered by Border Control Department of
the FSB of Russia Border Guard.

Please be informed that keeping by Border Guard authorities of border crossing records by the
name of persons crossing the state border of the Russian Federation is not prescribed by the
Russian law. In accordance with Art. 30, cl. 15 of the Law of the Russian Federation "On the
State Border of the Russian Federation", the records are maintained as to the actual number of
people crossing the border.

Due to the aforesaid, it is not possible to forward information you requested.

1st Deputy Head,
Department of Border Control (signature) <...>

(Round seal) (illegible)

(Stamp)
Investigative Committee of the Russian Federation
Chief Investigative Administration
10 May 2016

06.04.2016
201-12-2016

To: <...>,
Deputy Head,
Federal Customs Service

Address: 11/5 Novozavodskaya Street, Moscow 121087

Dear <...>,

The Chief Investigative Administration of the Investigative Committee of the Russian Federation, in accordance with the requirements of Art. 457 of the Criminal Procedure Code of the Russian Federation, is in the process of fulfilling the request of the competent bodies of Ukraine for legal assistance under criminal case #1201400000000283 initiated in connection with the offences under Art. 258-3, Section 1, Art. 294, Section 1, Art. 258, Section 3, Art. 341, Art. 348, and Art. 349 of the Criminal Code of Ukraine.

In connection with the execution of the said request, pursuant to Art. 21, Section 4 of the Criminal Procedure Code of the Russian Federation, please provide to the Chief Investigative Administration of the Investigative Committee of the Russian Federation information if in the period of from 01.01.2014 till present time the state border of the Russian Federation has been crossed by one Igor Nikolayevich Bezler, d.b. 30.12.1965, born in Simferopol, residing at: Ukraine, Donetsk Oblast, Gorlovka, Ulitsa Rudakova, 33A; Russian passport #1102600442 (no other information about the said person has been provided by the competent bodies of Ukraine). Please forward properly executed materials obtained in the course of fulfilling this request to the Investigative Committee of the Russian Federation at: 2 Tekhnicheskij Pereulok, Moscow, 105005, Russia.

Taking into consideration that the execution of the request for legal assistance of the competent bodies of Ukraine is under special control of the leadership of the Investigative Committee of the Russian Federation, I urgently ask you to execute it as soon as possible.

Senior investigator, Directorate for Investigation of Crimes related to the Use of Prohibited Means and Methods of Warfare, Chief Investigative Administration, Investigative Committee of the Russian Federation
Major of Justice (signature) <...>

Tel. (495) 966-95-10

(Round seal) (illegible)

(Stamp)
Investigative Committee of the Russian Federation
ref#ck251-10090-16/

From:
Federal Customs Service (FTS of Russia)

11/5 Novozavodskaya Street, Moscow 121087
Tel. (499) 72-35; fax (499) 449-73-00, (495) 913-93-90
Teletype 611385 VETO RU
E-mail: fts@ca.customs.ru, <http://www.customs.ru>

18 April 2016 # 18-18/18237
In response to: #201-12-2016 of 06.04.2016

To:
Lieutenant Colonel of Justice <...>,
Acting Head, Directorate for Investigation of Crimes related to the Use of Prohibited Means and
Methods of Warfare, Chief Investigative Administration, Investigative Committee of the Russian
Federation

Address: 2 Tekhnicheskij Per., Moscow 105005

Dear <...>,

The Federal Customs Service has considered the letter of the Chief Investigative Administration of the Investigative Committee of the Russian Federation sent within the process of executing the request of the competent bodies of Ukraine for legal assistance under criminal case #1201400000000283 initiated in connection with the offences under Art. 258-3, Section 1, Art. 294, Section 1, Art. 258, Section 3, Art. 341, Art. 348, and Art. 349 of the Criminal Code of Ukraine.

According to the Regulations of the Federal Customs Service enacted by Resolution #809 dated 16.09.2013 of the Government of the Russian Federation, the FTS of Russia performs customs control of goods crossing the state border. Keeping records of people crossing the state border of the Russian Federation is not within the scope of competence of the FTS of Russia.

Information on the facts of crossing the state border by persons can be requested from the Border Guard authorities of the FSB of Russia, which, in accordance with the Regulations of the Federal Security Service of the Russian Federation enacted by Decree #960 dated 11.08.2003 of the President of the Russian Federation, control the compliance by individual and legal persons with the border regime at the state border of the Russian Federation.

Head,
Administration of Customs Investigations and Enquiries
Lieutenant General (signature) <...>

Ex. by <...>
(499) 449 87 35

(Stamp)
Investigative Committee of the Russian Federation
Date: 20.04.2016 Time: 15:47
Ref.#BXCK-10180-16/

06.06.2016
#201-12-2016

To:
Chief Physician <...>,
Arkhangelsk Oblast GBUZ "Mirniy Central District Hospital"

Address: 3 Dzerzhinskiy Street, Mirniy, Arkhangelsk Oblast, 164170

The Chief Investigative Administration of the Investigative Committee of the Russian Federation, in accordance with the requirements of Art. 457 of the Criminal Procedure Code of the Russian Federation, is in the process of fulfilling the request of the competent bodies of Ukraine for legal assistance under criminal case #1201400000000283 initiated in connection with the suspected offences under Art. 258-3, Section 1, Art. 294, Section 1, Art. 258, Section 3, Art. 341, Art. 348, and Art. 349 of the Criminal Code of Ukraine.

In connection with the execution of the said request, please inform if Igor Nikolayevich Bezler, d.b. 30.12.1965, born in Simferopol, registered at: Arkhangelsk Oblast, Mirniy, Ulitsa Chaikovskogo, 6, apt. 46, is registered at your hospital as a patient of a psychiatrist or a narcologist.

Please report as soon as possible.

Senior investigator, Directorate for Investigation of Crimes related to the Use of Prohibited Means and Methods of Warfare, Chief Investigative Administration, Investigative Committee of the Russian Federation
Major of Justice (signature) <...>

Tel. (495) 966-95-10

(Round seal) (illegible)

(Stamp)
Investigative Committee of the Russian Federation
ref#ck251-18176-16/

From:
Ministry of Health of Arkhangelsk Oblast,
State Budgetary Healthcare Organisation of Arkhangelsk Oblast
“Mirniy Central City Hospital”

Address: 3 Dzerzhinskiy Street, Mirniy, Arkhangelsk Oblast 164170
Tel. (81834) 5 33 20; fax: 5 34 31
E-mail: mirzdrav@muzcgb.ru

08.06.2016
#2690/01-27m

In response to: # 201-12-2016 of 06.06.2016

To: Major of Justice <...>,
Senior investigator, Directorate for Investigation of Crimes related to the Use of Prohibited
Means and Methods of Warfare, Chief Investigative Administration, Investigative Committee of
the Russian Federation

Please be informed that Igor Nikolayevich Bezler, d.b. 30.12.1965, registered at: Arkhangelsk
Oblast, Mirniy, Ulitsa Chaikovskogo, 6, apt. 46, is not registered as a patient of a psychiatrist or
a psychiatrist-narcologist.

Acting Chief Physician (signature) <...>

Ex. by <...>
<...>

(Stamp)
Investigative Committee of the Russian Federation
22 June 2016

(Round seal) (illegible)

(Stamp)
Investigative Committee of the Russian Federation
Date: 22.06.2016 Time: 10:49
Ref.#BXCK-16895-16/

06.06.2016
#201-12-2016

To:
Chief Physician <...>,
Arkhangelsk Oblast GBUZ "Arkhangelsk Psychoneurological Hospital"

Address: 271 Lomonosov Ave., Arkhangelsk, 163001

The Chief Investigative Administration of the Investigative Committee of the Russian Federation, in accordance with the requirements of Art. 457 of the Criminal Procedure Code of the Russian Federation, is in the process of fulfilling the request of the competent bodies of Ukraine for legal assistance under criminal case #2201400000000283 initiated in connection with the suspected offences under Art. 258-3, Section 1, Art. 294, Section 1, Art. 258, Section 3, Art. 341, Art. 348, and Art. 349 of the Criminal Code of Ukraine committed by Russian citizen I.N. Bezler.

In connection with the execution of the said request, please inform if Igor Nikolayevich Bezler, d.b. 30.12.1965, born in Simferopol, registered at: Arkhangelsk Oblast, Mirniy, Ulitsa Chaikovskogo, 6, apt. 46, is registered as a patient of a psychiatrist or a narcologist. Please report by snail mail as soon as possible.

Senior investigator, Directorate for Investigation of Crimes related to the Use of Prohibited Means and Methods of Warfare, Chief Investigative Administration, Investigative Committee of the Russian Federation
Major of Justice (signature) <...>

Tel. (495) 966-95-10

(Round seal) (illegible)

(Stamp)
Investigative Committee of the Russian Federation
ref#ck251-18166-16/

06.06.2016
#201-12-2016

To:
Chief Physician <...> “Arkhangelsk Psychoneurological Hospital”

Address: 271 Lomonosov Ave., Arkhangelsk, 163001

The Chief Investigative Administration of the Investigative Committee of the Russian Federation, in accordance with the requirements of Art. 457 of the Criminal Procedure Code of the Russian Federation, is in the process of fulfilling the request of the competent bodies of Ukraine for legal assistance under criminal case #2201400000000283 initiated in connection with the suspected offences under Art. 258-3, Section 1, Art. 294, Section 1, Art. 258, Section 3, Art. 341, Art. 348, and Art. 349 of the Criminal Code of Ukraine supposedly committed by Russian citizen I.N. Bezler.

In connection with the execution of the said request, please inform if Igor Nikolayevich Bezler, d.b. 30.12.1965, born in Simferopol, registered at: Arkhangelsk Oblast, Mirniy, Ulitsa Chaikovskogo, 6, apt. 46, is registered as a patient of a psychiatrist or a narcologist. Please report by snail mail as soon as possible.

Senior investigator, Directorate for Investigation of Crimes related to the Use of Prohibited Means and Methods of Warfare, Chief Investigative Administration, Investigative Committee of the Russian Federation
Major of Justice (signature) <...>
Tel. (495) 966-95-10

(Stamp)
Investigative Committee of the Russian Federation
Chief Investigative Administration
6 July 2016

(Round seal) (illegible)

(Stamp)
Investigative Committee of the Russian Federation
ref#ck251-18166-16/

(more illegible stamps and signatures)

06.06.2016
#201-12-2016

To:
Lieutenant Colonel of Police <...>,
Head, Inter-Municipal Department for Mirniy Closed Administrative and Territorial Unit (ZATO
Mirniy), MVD of Russia

Address: 36, Dzerzhinskiy Street, Mirniy, Arkhangelsk Oblast, 161170

Dear <...>,

The Chief Investigative Administration of the Investigative Committee of the Russian Federation, in accordance with the requirements of Art. 457 of the Criminal Procedure Code of the Russian Federation, is in the process of fulfilling the request of the competent bodies of Ukraine for legal assistance under criminal case #2201400000000283 initiated in connection with the suspected offences under Art. 258-3, Section 1, Art. 294, Section 1, Art. 258, Section 3, Art. 341, Art. 348, and Art. 349 of the Criminal Code of Ukraine supposedly committed by Russian citizen I.N. Bezler.

In connection with that request, I hereby forward to you an assignment for the performance of investigative measures.

Please inform the Chief Investigative Administration of the Investigative Committee of the Russian Federation of the results of the performance of this assignment within the time set by law.

Annex: according to the above, 1 page.

Senior investigator, Directorate for Investigation of Crimes related to the Use of Prohibited Means and Methods of Warfare, Chief Investigative Administration, Investigative Committee of the Russian Federation
Major of Justice (signature) <...>

Tel. (495) 966-95-10

(Round seal) (illegible)

(Stamp)
Investigative Committee of the Russian Federation
ref#ck251-18161-16/

From:
Administration of MVD of Russia for Arkhangelsk Oblast,
Inter-Municipal Department for Mirniy Closed Administrative and Territorial Unit (ZATO
Mirniy)

Address: 36, Dzerzhinskiy Street, Mirniy, Arkhangelsk Oblast, 161170
Tel. (8-81834) 5-11-88
24.06.2016
#4/b/n

In response to: Request

To:
Major of Justice <...>
Senior investigator, Directorate for Investigation of Crimes related to the Use of Prohibited
Means and Methods of Warfare, Chief Investigative Administration, Investigative Committee of
the Russian Federation

Address: 2 Tekhnicheskoy Per., Moscow 105005
Fax: 8-495-966-91-62

In response to your request, please be informed that Inter-Municipal Department for ZATO
Mirniy has performed a set of investigative measures aimed at identifying close acquaintances
and relatives of Igor Nikolayevich Bezler, d.b. 30.12.1965, born in Simferopol, registered at:
Arkhangelsk Oblast, Mirniy, Ulitsa Chaikovskogo, 6, apt. 46.

As a result of the performed measures it has been established that Igor Nikolayevich Bezler
checked out of the address of: Arkhangelsk Oblast, Mirniy, Ulitsa Chaikovskogo, 6, apt. 46,
on 24.01.2003, and left the ZATO Mirniy territory for an unknown destination.

I.N.Bezler's wife Vera Petrovna Bezler, d.b. 22.11.1969, resided at: Mirniy, Dzerzhinskiy Street,
46, apt. 56. She checked out of this address on 03.05.2007 and left the ZATO Mirniy territory for
an unknown destination.

Whereabouts of the above persons, other I.N. Bezler's close acquaintances or relatives at the
territory of ZATO Mirniy have not been established; the Criminal Investigation Department of
MVD of Russia Department for ZATO Mirniy has no further information as to their possible
whereabouts.

Sincerely yours,
Police Deputy Head for Operations,
Head, Criminal Investigation Department of MVD of Russia Department for ZATO Mirniy,
Major of Police (signature) <...>

Ex. by <...>
Tel. 8-818-34-5-11-88

(Round seal) (illegible)

Copy verified (signature)

06.06.2016
#201-12-2016

To:

<...>,

Head, Mirniy Department, Administration of FMS of Russia for Arkhangelsk Oblast

Address: 36, Dzerzhinskiy Street, Mirniy, Arkhangelsk Oblast, 161170

The Chief Investigative Administration of the Investigative Committee of the Russian Federation, in accordance with the requirements of Art. 457 of the Criminal Procedure Code of the Russian Federation, is in the process of fulfilling the request of the competent bodies of Ukraine for legal assistance under criminal case #2201400000000283 initiated in connection with the suspected offences under Art. 258-3, Section 1, Art. 294, Section 1, Art. 258, Section 3, Art. 341, Art. 348, and Art. 349 of the Criminal Code of Ukraine supposedly committed by Russian citizen I.N. Bezler.

In connection with that request, please forward to our address a properly certified copy of Form #1 of Passport Application in the name of Igor Nikolayevich Bezler, d.b. 30.12.1965 (possesses passport ser. 1115 #076740 issued 17.03.2016 by the Migration Unit of FMA of Russia Administration for Arkhangelsk Oblast and Nenets Autonomous Okrug in Mirniy).

Besides, there is information in the records that I.N. Bezler had earlier received Russian passport ser. 1102 #600442 date of issuance: 12.07.2002, issued by Mirninskoye GOVD of Arkhangelsk Oblast. As of 20.04.2016 the passport is recorded as "invalid" (reported missing).

In connection with the above, please inform of the reasons and grounds for the invalidity of the said passport and its being reported as missing (searched).

Please provide a report by snail mail as soon as possible.

Senior investigator, Directorate for Investigation of Crimes related to the Use of Prohibited Means and Methods of Warfare, Chief Investigative Administration, Investigative Committee of the Russian Federation

Major of Justice (signature) <...>

Tel. (495) 966-95-10

(Round seal) (illegible)

(Stamp)

From:
FMS of Russia,
FMS of Russia Administration for Arkhangelsk Oblast and Nenets Autonomous Okrug,
Migration Unit for Arkhangelsk Oblast and Nenets Autonomous Okrug in the town of Mirniy

Address: 36, Dzerzhinskiy Street, Mirniy, Arkhangelsk Oblast, 161170
Tel. (8-81834) 5-11-84
Fax: 5-43-95

24.06.2016
#1906

In response to: _____ dated _____

To:
Major of Justice <...>
Senior investigator, Directorate for Investigation of Crimes related to the Use of Prohibited
Means and Methods of Warfare, Chief Investigative Administration, Investigative Committee of
the Russian Federation

Address: 2 Tekhnicheskii Per., Moscow 105005
Fax: 8-495-966-91-62

In response to your request, please receive a copy of Form 1P in the name of Igor Nikolayevich
Bezler, d.b. 30.12.1965, born in Simferopol of Crimea Oblast. Please be informed that the said
passport was issued due to the loss of passport ser. 1102 #600442 issued 12.07.2002 by Mirniy
GOVD of Arkhangelsk Oblast (which is why it is recorded as missing).

Annex: 1 copy on 1 page.

Migration Unit Head,
Civil servant 3rd class assistant (signature) <...>

(Round seal) (illegible)

(Stamp)
Investigative Committee of the Russian Federation
Date: 07.07.2016 Time: 12:45
Ref.#(illegible)

APPLICATION FOR (RE)ISSUE OF PASSPORT (COPY)

Date: 17.03.2016

1. (surname, name, patronymic) Bezler Igor Nikolayevich
2. (date, month, year of birth) 30.12.1965
3. Gender – male
4. (place of birth) city of Simferopol, Crimea Oblast
5. (marital status; if married state surname, name, patronymic, date of birth of spouse, by which ZAGS and when registered) married, Samoenko Vera Petrovna, 22.11.1969, Mirniy TOA ZAGS, 31.08.2002, civil record 187
6. (surname, name, patronymic of father and mother) Bezler Nikolay Fedorovich, Bezler Lyudmila Tikhonovna
7. (place of residence-place of application: name of oblast, city, township, village, street, house, building, flat) Arkhangelsk Oblast, Mirniy, Ulitsa Chaikovskogo, 6, apt. 46.
8. (other citizenship, grounds for applying for Russian citizenship)
9. (Please re-issue passport: state reason for issue/reissue of passport, date, signature) to replace lost passport, 17.02.2016, signed.
10. (signature of) Bezler I.A. (is hereby certified) (signature)
11. Issue passport based on (type of document, series, number, when and by whom issued): passport 1102 600442, Mirniy GOVD of Arkhangelsk Oblast, 12.07.2002

(date of receipt of all documents) 17 February 2016

(signature of division employee)

(division head) signature

(passport issued by)

(passport received: surname, name, patronymic) Bezler Igor Nikolayevich

(date) 15.04.16

(signature)

12. Changed surname, name, patronymic or other records
13. Formerly had Russian passport (division code, passport series, passport number, date)
14. Issued primary document certifying the identity of a citizen beyond Russian borders: (division code, passport series, passport number, date)
15. Request received from (name of division) in connection with (state reason)
16. Information received from (name of territorial body of FMS of Russia) about destruction in connection with (state reason)
17. Passport destroyed and records made by (name of division having destroyed passport, division code, passport series, passport number, date)
18. Other information: registered from 29.08.2000 until 24.01.2003 in Mirniy, Ulitsa Chaikovskogo, 6-46.

COPY VERIFIED

Seal, stamp

To: Federal Security Service of the Russian Federation

Address: 1/3 Bolshaya Lubyanka, Moscow, 101000

05.05.2016

#201-12-2016

Letter of Commission
for the performance of investigative measures

The Chief Investigative Administration of the Investigative Committee of the Russian Federation, in accordance with the requirements of Art. 457 of the Criminal Procedure Code of the Russian Federation, is in the process of fulfilling the request of the competent bodies of Ukraine for legal assistance under criminal case #1201400000000258 initiated in connection with the offences under Art. 258-3, Section 1, Art. 294, Section 1, Art. 258, Section 3, Art. 341, Art. 348, and Art. 349 of the Criminal Code of Ukraine.

In connection with the execution of the said request, at this time it is necessary to identify close acquaintances and relatives of Igor Nikolayevich Bezler, d.b. 30.12.1965, born in Simferopol, residing at: Ukraine, Donetsk Oblast, Gorlovka, Ulitsa Rudakova, 33A; supposedly having Russian passport #1102600442 (no other information about the said person has been provided by the competent bodies of Ukraine).

Based on the above and pursuant to Art.38, section 2, cl.4 of the Criminal Procedure Code of the Russian Federation,

I hereby request:

To perform a set of investigative measures aimed at the identification of close acquaintances and relatives of Igor Nikolayevich Bezler.

Please complete this commission within the time frame set by the law.

Please execute results in accordance with the Instruction enacted by joined orders #776 of MVD of Russia, 3703 of the Ministry of Defense of Russia, #509 of FSB of Russia, #507 of FSO of Russia, #1820 of FTS of Russia, #42 of SVR of Russia, #535 of FSIN of Russia, #398 of FSKN of Russia, #68 of SK of Russia, all dated 27.09.2013.

Senior investigator, Directorate for Investigation of Crimes related to the Use of Prohibited Means and Methods of Warfare, Chief Investigative Administration, Investigative Committee of the Russian Federation

Major of Justice (signature) <...>

Tel. (495) 966-95-10

(Round seal) (illegible)

(Stamp)

Investigative Committee of the Russian Federation

ref#ck251-14247-16/

05.05.2016
#201-12-2016

To:
Major-General of Police <...>,
Head,
Chief Administration for Countering Extremism of MVD of Russia

Address: 1/2 Sadovaya-Spasskaya Street, Moscow, 107078

Dear <...>,

The Chief Investigative Administration of the Investigative Committee of the Russian Federation, in accordance with the requirements of Art. 457 of the Criminal Procedure Code of the Russian Federation, is in the process of fulfilling the request of the competent bodies of Ukraine for legal assistance under criminal case #1201400000000258 initiated in connection with the offences under Art. 258-3, Section 1, Art. 294, Section 1, Art. 258, Section 3, Art. 341, Art. 348, and Art. 349 of the Criminal Code of Ukraine.

In connection with the execution of the said request, I hereby forward to your address a letter of commission to perform investigative measures.

Please inform the Chief Investigative Administration of the Investigative Committee of the Russian Federation on the course and results of the performance of this commission.

Annex: according to the above, 1 page.

Senior investigator, Directorate for Investigation of Crimes related to the Use of Prohibited Means and Methods of Warfare, Chief Investigative Administration, Investigative Committee of the Russian Federation

Major of Justice (signature) <...>

Tel. (495) 966-95-10

(Round seal) (illegible)

(Stamp)

Investigative Committee of the Russian Federation
ref#ck251-14253-16/

From:
Ministry of Internal Affairs of the Russian Federation (MVD of Russia),
Chief Administration for Countering Extremism (GUPE)

Address: 1/2, b.1, Sadovaya-Spasskaya Street, Moscow, 107078

20/05/16 #30/2157

In response to: #201-12-2016 of 05.05.2016

To:
Lieutenant Colonel <...>,
Deputy Head,
Directorate for Investigation of Crimes related to the Use of Prohibited Means and Methods of
Warfare, Chief Investigative Administration, Investigative Committee of the Russian Federation

On performance of commission

Dear <...>,

Chief Administration for Countering Extremism of MVD of Russia, while executing the
commission for the performance of investigative measures in accordance with the request of the
competent bodies of Ukraine for legal assistance under criminal case #1201400000000258
initiated in connection with the offences under Art. 258-3, Section 1, Art. 294, Section 1, Art.
258, Section 3, Art. 341, Art. 348, and Art. 349 of the Criminal Code of Ukraine, has no
information about close acquaintances and relatives of Igor Nikolayevich Bezler, d.b.
30.12.1965.

In case of any information of interest becoming available, we will immediately inform you
thereof.

Deputy Head,
Colonel of Police (signature) <...>

(Round seal) (illegible)

(Stamp)
Investigative Committee of the Russian Federation
Date: 25.05.2016. Time: 09:52
ref#BXCK-13526-16/

05.05.2016
#201-12-2016

To:
Major-General of Police <...>,
Head,
Chief Administration for Countering Extremism of MVD of Russia

Address: 1/2 Sadovaya-Spasskaya Street, Moscow, 107078

Letter of Commission
for the performance of investigative measures

The Chief Investigative Administration of the Investigative Committee of the Russian Federation, in accordance with the requirements of Art. 457 of the Criminal Procedure Code of the Russian Federation, is in the process of fulfilling the request of the competent bodies of Ukraine for legal assistance under criminal case #1201400000000258 initiated in connection with the offences under Art. 258-3, Section 1, Art. 294, Section 1, Art. 258, Section 3, Art. 341, Art. 348, and Art. 349 of the Criminal Code of Ukraine.

In connection with the execution of the said request, at this time it is necessary to identify close acquaintances and relatives of Igor Nikolayevich Bezler, d.b. 30.12.1965, born in Simferopol, residing at: Ukraine, Donetsk Oblast, Gorlovka, Ulitsa Rudakova, 33A; allegedly having Russian passport #1102600442 (no other information about the said person has been provided by the competent bodies of Ukraine).

Based on the above and pursuant to Art.38, section 2, cl.4 of the Criminal Procedure Code of the Russian Federation,

I hereby request:

To commission subordinate officers of the Chief Administration for Countering Extremism to perform a set of investigative measures aimed at the identification of close acquaintances and relatives of Igor Nikolayevich Bezler.

Please complete this commission within the time frame set by the law.

Please execute results in accordance with the Instruction enacted by joined orders #776 of MVD of Russia, 3703 of the Ministry of Defense of Russia, #509 of FSB of Russia, #507 of FSO of Russia, #1820 of FTS of Russia, #42 of SVR of Russia, #535 of FSIN of Russia, #398 of FSKN of Russia, #68 of SK of Russia, all dated 27.09.2013.

Senior investigator, Directorate for Investigation of Crimes related to the Use of Prohibited Means and Methods of Warfare, Chief Investigative Administration, Investigative Committee of the Russian Federation

Major of Justice (signature) <...>

Tel. (495) 966-95-10

(Round seal) (illegible)

(Stamp)

Investigative Committee of the Russian Federation

ref#ck251-14254-16/14253

Formal Request
ZIC GUV D for the city of Moscow
(name of body to which request is forwarded)

1. Surname: Bezler
2. Name and patronymic: Igor Nikolayevich
3. Date of birth: 30.12.1965
4. Place of birth: city of Simferopol
5. Address: Ukraine, Donetsk Oblast, Gorlovka, Ulitsa Rudakova, 3
6. Grounds for search: investigation of criminal case #2201505000000258.
7. Requested information: record of criminal and administrative offences and punishments

Senior investigator, Directorate for Investigation of Crimes related to the Use of Prohibited Means and Methods of Warfare, Chief Investigative Administration, Investigative Committee of the Russian Federation

Major of Justice (signature) <...>

Sender's address: 2 Tekhnicheskii Per, Moscow, 105005

Name of body: Chief Investigative Administration of the Investigative Committee of the Russian Federation

Recipient's address: 38 Petrovka Street, Moscow, 127994

Note: Formal request must be filled in clearly and legibly; surname, name and patronymic must be written in printed letters in nominative case.

(Round seal) (illegible)

Formal Request
IC GU MVD of Russia for Moscow Oblast
(name of body to which request is forwarded)

1. Surname: Bezler
2. Name and patronymic: Igor Nikolayevich
3. Date of birth: 30.12.1965
4. Place of birth: city of Simferopol
5. Address: Ukraine, Donetsk Oblast, Gorlovka, Ulitsa Rudakova, 3
6. Grounds for search: investigation of criminal case #2201505000000258.
7. Requested information: record of criminal and administrative offences and punishments

Senior investigator, Directorate for Investigation of Crimes related to the Use of Prohibited Means and Methods of Warfare, Chief Investigative Administration, Investigative Committee of the Russian Federation

Major of Justice (signature) <...>

Sender's address: 2 Tekhnicheskiy Per, Moscow, 105005

Name of body: Chief Investigative Administration of the Investigative Committee of the Russian Federation

Recipient's address: 3 Nikitskiy Per., Moscow, 125009

Note: Formal request must be filled in clearly and legibly; surname, name and patronymic must be written in printed letters in nominative case.

(Round seal) (illegible)

Formal Request
MIAC MVD RF

(name of body to which request is forwarded)

1. Surname: Bezler
2. Name and patronymic: Igor Nikolayevich
3. Date of birth: 30.12.1965
4. Place of birth: city of Simferopol
5. Address: Ukraine, Donetsk Oblast, Gorlovka, Ulitsa Rudakova, 3
6. Grounds for search: investigation of criminal case #22015050000000258.
7. Requested information: record of criminal and administrative offences and punishments

Senior investigator, Directorate for Investigation of Crimes related to the Use of Prohibited Means and Methods of Warfare, Chief Investigative Administration, Investigative Committee of the Russian Federation

Major of Justice (signature) <...>

Sender's address: 2 Tekhnicheskoy Per, Moscow, 105005

Name of body: Chief Investigative Administration of the Investigative Committee of the Russian Federation

Recipient's address: 67 Novocheremushkinskaya Street, Moscow, 117418

Note: Formal request must be filled in clearly and legibly; surname, name and patronymic must be written in printed letters in nominative case.

(Round seal) (illegible)

Annex 51

Letter from the Office of the Prosecutor-General of the Russian Federation No. 82/1-5095-15,
18 November 2016

(translation)

Translation

Letter from the Office of the Prosecutor General of the Russian Federation No. 82/1-5095-15, 18 November 2016.

To: <...>,

Head of International Legal Cooperation and
European Integration Administration,

18.11.2016 82/1-5095-15
14/3-31144-15

Office of the Prosecutor General of Ukraine

Dear <...>,

The Office of the Prosecutor General of the Russian Federation sends its compliments to the Office of the Prosecutor General of Ukraine, and, in accordance with the European Convention on Mutual Assistance in Criminal Matters dated 20.04.1959 and the Convention on Legal Aid and Legal Relations in Civil, Family and Criminal Cases dated 22.01.1993, forwards materials obtained in the course of the execution of the request of GSU USB of Ukraine for legal assistance under criminal case No.22014000000000245 against A.Yu. Boroday.

Annex: on 3 pages

Yours sincerely

(signature)

Acting Head, Administration for Legal Assistance, Chief Administration of International Legal
Cooperation <...>

Executed by: <...>
Tel. (495) 982-41-55

(signed) 18.11.16

(Stamp)
Office of the Prosecutor General of the Russian Federation
No. 82/1-5095 дсп-2015/Нд41450-16

11.04.2016 #201-12-2016

To:

R.V. Davydov,
Deputy Head, Federal Customs Service of Russia
Address: 11/5, Novozavodskaya Street, Moscow 121087

Dear Ruslan Valentinovich,

The Chief Investigative Administration of the Investigative Committee of the Russian Federation, in accordance with the requirements of Art. 457 of the Criminal Procedure Code of the Russian Federation, is in the process of fulfilling the request of the competent bodies of Ukraine for legal assistance under criminal case #2201400000000245 initiated in connection with the offences under Art. 258-3, Section 1, Art. 110, Section 2, Art. 28, Section 2, and Art. 109, section 1 of the Criminal Code of Ukraine.

In connection with the necessity, in accordance with paragraph 4 of Article 21 of the Criminal Procedure Code of the Russian Federation, please inform the Chief Investigative Administration of the Investigative Committee of the Russian Federation, whether Aleksandr Yuryevich Boroday, d.b. 07.191972, crossed the border of the Russian Federation in the period from 01.01.2014 to date (no other information about this person was provided by the competent authorities of Ukraine).

In you need to clarify possible issues related to the execution of this request, please contact Timofey Vladimirovich Grachov, senior investigator of the second investigation department of the department for the investigation of crimes involving the use of prohibited means and methods of warfare of the Chief Investigative Directorate of the Investigative Committee of the Russian Federation, by phone at (495) 966-95-98.

Due to the fact that the execution of the request for legal assistance from the competent authorities of Ukraine is under the special control of the leadership of the Investigative Committee of the Russian Federation, I urgently ask you to execute it as soon as possible.

Senior investigator,
Chief Investigative Directorate,
Major of Justice

(signature)

T.V. Grachov

(Stamp)

Investigative Committee of the Russian Federation
Ref.#СК-251-10802-16/

From:
Federal Customs Service (FTS of Russia)

11/5 Novozavodskaya Street, Moscow 121087
Tel. (499) 72-35; fax (499) 449-73-00, (495) 913-93-90
Teletype 611385 VETO RU
E-mail: fts@ca.customs.ru, <http://www.customs.ru>

18 April 2016 # 18-18/18228
In response to: #201-12-2016 of 11.04.2016

To:
Lieutenant Colonel of Justice A.O. Pischulin,
Acting Head, Bureau for Investigation of Crimes related to the Use of Prohibited Means and
Methods of Warfare, Chief Investigative Administration, Investigative Committee of the Russian
Federation
Address: 2 Tekhnicheskiy Per., Moscow 105005

On forwarding information

Dear Alexey Olegovich,

The Federal Customs Service has considered the letter of the Chief Investigative Administration of the Investigative Committee of the Russian Federation sent within the process of executing the request of the competent bodies of Ukraine for legal assistance under criminal case #2201400000000245 initiated in connection with the offences under Art. 258-3(1) Art. 110(2), Art. 28(2), and Art. 109 of the Criminal Code of Ukraine.

According to the Regulations of the Federal Customs Service enacted by Resolution #809 dated 16.09.2013 of the Government of the Russian Federation, the FTS of Russia performs customs control of goods crossing the state border. Keeping records of people crossing the state border of the Russian Federation is not within the scope of competence of the FTS of Russia.

Information on the facts of crossing the state border by persons can be requested from the Border Guard authorities of the FSB of Russia, which, in accordance with the Regulations of the Federal Security Service of the Russian Federation enacted by Decree #960 dated 11.08.2003 of the President of the Russian Federation, control the compliance by individual and legal persons with the border regime at the state border of the Russian Federation.

Head,
Administration of Customs Investigations and Enquiries
Lieutenant General of the Customs Service (signature)

A.P. Kizlyk

Ex. by S.N. Netukov
(499) 449 87 35

(Stamp)
Investigative Committee of the Russian Federation
Date: 20.04.2016 Time: 16:03
Ref.#BXCK-10191-16/

INVESTIGATIVE COMMITTEE OF THE RUSSIAN FEDERATION

2 Tekhnicheskij Per., Moscow, 105005

REQUEST

for a search in the records of GIAC MVD of Russia (GIC MVD of Russia, ZIC GUVVD of Moscow, IC GUVVD of Moscow Oblast, IC UVD of Krai/Oblast

Hereby we request to conduct a search and provide a certificate:

- | | |
|-------------------------------|---|
| 1. (Surname) | Boroday |
| 2. (Name and patronymic) | Alexander Yurievich |
| 3. (Date of birth) | 25 July 1972 |
| 4. (Place of birth) | Moscow |
| 5. (Place of residence) | ----- |
| 6. (certificate requested on) | criminal record |
| 7. (request related to) | investigation of criminal case #201-12-2016 |

Senior investigator, 1st investigative department, Bureau for Investigation of Crimes related to the Use of Prohibited Means and Methods of Warfare, Chief Investigative Administration, Investigative Committee of the Russian Federation
Major of Justice (signature) T.V. Grachev

10 June 2016

From:
Psychoneurological Clinic (PND) #1,
Branch of State Budgetary Healthcare Organisation of the city of Moscow
“Psychiatric Hospital #1 Named after N.A. Alexeyev”
Department of Healthcare of Moscow
Address: 6 Mosfilmovskaya Street, Moscow 119285
Tel. (499) 143-49-20 Fax: (499) 147-22-05
E-mail: pkb1-pnd1@zdrav.mos.ru

Date: 08.07.2016 #837

In response to your request dated 08.07.2016 please be informed that there is no medical information in the records of Psychoneurological Clinic #1 concerning Alexander Yurievich Boroday, d.b. 25.07.1972, registered at: Moscow, Prospekt Vernadskogo, 97, b.1, apt.118.

Deputy Chief Physician for the Medical Section of the Branch (signature) S.A. Golubev

(Round seal) Psychoneurological Clinic #1

(pink slip 1) his address is provided

(pink slip 2) since we do not disclose info on his place of registration, PND certificate is not to be forwarded either.

Annex 52

Letter from the Office of the Prosecutor-General of the Russian Federation No. 82/1-5099-15
dated 16 November 2016

(translation)

Translation

Letter from the Office of the Prosecutor General of the Russian Federation No. 82/1-5099-15, 16 November 2016.

To: <...>,

Head of International Legal Cooperation and
European Integration Administration,

16.11.2016 82/1-5099-15
14/3-31157-15

Office of the Prosecutor General of Ukraine

Dear <...>,

The Office of the Prosecutor General of the Russian Federation sends its compliments to the Office of the Prosecutor General of Ukraine, and, in accordance with the European Convention on Mutual Assistance in Criminal Matters dated 20.04.1959 and Art.7 (1)(g) of the Convention on Legal Aid and Legal Relations in Civil, Family and Criminal Cases dated 22.01.1993, forwards materials obtained in the course of the execution of the request of the Chief Investigative Administration of the Security Service of Ukraine for legal assistance under criminal case #22014000000000286.

Annex: on 5 pages

Yours sincerely

(signature)

Acting Head, Administration for Legal Assistance, Chief Administration of International Legal
Cooperation <...>

Executed by: <...>
Tel. (495) 982-41-55

(signed) 17.11.16

(signed) 16.11.16

(Stamp)

Office of the Prosecutor General of the Russian Federation
#82/1-5099дсп-2015/Нд41135-16

From:
FMS of Russia,
Federal Migration Service Administration for the city of Moscow (UFMS of Russia for Moscow)

Address: 16/4, b.4, B. Ordynka Street, Moscow, 115035
Tel. 8(499) 230-72-24
Fax: 8(499)230-72-64
<http://www.77.fms.gov.ru>

12.05.2016 #MO-9/9-5134n

To:
<...>,
Senior investigator, 1st investigative department, Bureau for Investigation of Crimes related to
the Use of Prohibited Means and Methods of Warfare, Chief Investigative Administration,
Investigative Committee of the Russian Federation
Address: 2 Tekhnicheskyy Per., Moscow, 105005

Dear <...>,

In response to your request please be informed that, according to the Territoria PPO database,
Igor Vsevolodovich Girkin is a Russian citizen and has Russian passport ser. 4505 #502291,
issued 19.01.2016 by the UFMS of Russia department for Moscow, Bibirevo District.
Information of the issuance of a foreign passport of the Russian Federation is not available.
According to SPO Migrant-1 Central Foreign Nationals Registration Database, Igor
Vsevolodovich Girkin, d.b. 17.12.1970, is not in its records.

Respectfully,

Head,
OOIK Department (signature) <...>

(Stamp)
Investigative Committee of the Russian Federation
Date: 27.05.2016, Time: 14:29
ref#BXCK-13897-16/

From:
Ministry of Internal Affairs of the Russian Federation (MVD of Russia),
Chief Administration for the city of Moscow (GU MVD of Russia for Moscow),
Centre for Countering Extremism

Address: 38, Petrovka Street, Moscow, 124994
Tel. 8(495) 694-91-32
Fax: 8(495)698-67-82

31.05.2016 #84/1691

In response to: #201-12-2016 of 17.05.2016, AB 0762136

To:
<...>,
Senior investigator, 1st investigative department, Bureau for Investigation of Crimes related to
the Use of Prohibited Means and Methods of Warfare, Chief Investigative Administration,
Investigative Committee of the Russian Federation

On forwarding information

Dear <...>,

Please be informed that the Centre for Countering Extremism of GU MVD of Russia for
Moscow has no operationally significant information about Igor Vsevolodovich Girkin (Ivan
Ivanovich Strelkov), d.b. 17.12.1970, a native of Moscow, registered at: Moscow, Shenkurinsky
proezd, 8B, apt.136.

Respectfully,

Head,
Colonel of Police (signature) <...>

(Stamp)
Investigative Committee of the Russian Federation
Date: 08.06.2016, Time: 09:40
ref#BXCK-15254-16/

From:
Federal Customs Service (FTS of Russia)

Address: 11/5, Novozavodskaya Street, Moscow, 121087
Tel. 8(499) 449-72-35
Fax: 8(499)449-73-00
Teletype: 611385 VETO RU
E-mail: fts@ca.customs.ru, <http://www.customs.ru>

18.04.2016 #18-18/18235

In response to: #201-12-2016 of 11.04.2016

To:
Lieutenant Colonel <...>,
Acting Head, Bureau for Investigation of Crimes related to the Use of Prohibited Means and
Methods of Warfare, Chief Investigative Administration, Investigative Committee of the Russian
Federation
Address: 2 Tekhnicheskoy Per., Moscow, 105005

Dear <...>,

The Federal Customs Service has considered the letter of the Chief Investigative Department of the Investigative Committee of Russia sent in response to the request of the competent authorities of Ukraine for legal assistance in criminal case No. 220140000000286, initiated in connection with the offence under Art. 258-3, Section 1, Art. 294, Section 3, Art. 258, Art. 341, Art. 348, and Art. 349 of the Criminal Code of Ukraine.

According to the Regulations of the Federal Customs Service enacted by Resolution #809 dated 16.09.2013 of the Government of the Russian Federation, the FTS of Russia performs customs control of goods crossing the state border. Keeping records of people crossing the state border of the Russian Federation is not within the scope of competence of the FTS of Russia.

Information on the facts of crossing the state border by persons can be requested from the Border Guard authorities of the FSB of Russia, which, in accordance with the Regulations of the Federal Security Service of the Russian Federation, enacted by Decree #960 dated 11.08.2003 of the President of the Russian Federation, control the compliance by individual and legal persons with the border regime at the state border of the Russian Federation.

Head,
Administration of Customs Investigations and Enquiries
Lieutenant General of the Customs Service (signature) <...>

Ex. by <...>
(499) 449 87 35

(Stamp)
Investigative Committee of the Russian Federation
Date: 20.04.2016 Time: 15:50
Ref.#BXCK-10182-16/

To:
Major of Justice <...>,
Acting Head, Bureau for Investigation of Crimes related to the Use of Prohibited Means and
Methods of Warfare, Chief Investigative Administration, Investigative Committee of the Russian
Federation

REPORT

I hereby report that the Chief Investigative Department of the Investigative Committee of Russia, in accordance with the requirements of Art. 457 of Criminal Procedure Code of the Russian Federation, has fulfilled the request of the competent authorities of Ukraine for legal assistance in criminal case No. 22014000000286 implicating I.V. Girkin, a Russian citizen, who is suspected of committing crimes under Art. 258-3, Section 1, Art. 294, Section 3, Art. 258, Art. 341, Art. 348, and Art. 349 of the Criminal Code of Ukraine.

In the course of work under said request of legal assistance, it was not possible to interrogate I.V. Girkin and his close relatives due to the failure to establish their places of residence.

Taking into consideration the aforesaid, I think it necessary to add this report to completed materials of the request for legal assistance.

Senior Investigator,
Chief Investigative Administration,
Major of Justice (signature) <...>

(Round seal) (illegible)

INVESTIGATIVE COMMITTEE OF THE RUSSIAN FEDERATION
2 Tekhnicheskij Per., Moscow, 105005

REQUEST

for a search in the records of GIAC MVD of Russia (GIC MVD of Russia, ZIC GUVVD of Moscow, IC GUVVD of Moscow Oblast, IC UVD of Krai/Oblast

Hereby we request to conduct a search and provide a certificate:

- | | |
|----------------------------|---|
| 1. (Surname) | Girkin |
| 2. (Name and patronymic) | Igor Vsevolodovich |
| 3. (Date of birth) | 17 December 1970 |
| 4. (Place of birth) | |
| 5. (Place of residence) | Moscow, Shenkurskiy Proezd, 8B, apt. 136 |
| 6. (certificate requested) | criminal record |
| 7. (request related to) | investigation of criminal case #201-12-2016 |

Senior investigator, 1st investigative department, Bureau for Investigation of Crimes related to the Use of Prohibited Means and Methods of Warfare, Chief Investigative Administration, Investigative Committee of the Russian Federation
Major of Justice (signature) <...>

Annex 53

Letter from the Office of the Prosecutor-General of the Russian Federation No. 87-200-2015, 29
February 2016

(translation)

Translation

Letter from the Office of the Prosecutor-General of the Russian Federation No. 87-200-2015, 29 February 2016.

Prosecutor General's Office of the Russian Federation

Bolshaya Dmitrovka Street, 15a, Moscow, Russia, GSP-3, 125993

29.02.2016 #87-200-2015
In response to: 14/3-31150-15

To: <...>,
Head of International Legal Cooperation Department,
Prosecutor General's Office of Ukraine

Dear <...>,

The Prosecutor General's Office of the Russian Federation presents its compliments to the Prosecutor General's Office of Ukraine and hereby informs that the request of the Prosecutor General's Office of Ukraine for legal assistance dated 28.07.2015 on criminal case 4201400000000457 has been given consideration.

The request has been found impossible to satisfy due to the grounds provided in Art.2b of the European Convention on Mutual Legal Assistance in Criminal Matters dated 20.04.1959, Art.19 of the Convention on Legal Aid and Legal Relations in Civil, Family and Criminal Cases dated 22 January 1993, and Art. 457.4 of the Criminal Procedure Code of the Russian Federation.

Annex: on 482 pages

Head of the Department of International Cooperation on Special Cases (in right of a Directorate) of the Chief Administration for International Legal Cooperation (signature) <...>

Annex 54

Letter from the Office of the Prosecutor-General of the Russian Federation No. 82/1-2791-15,
25 September 2015

(translation)

Translation

Letter from the Office of the Prosecutor General of the Russian Federation No. 82/1-2791-15, 25 September 2015.

From: Office of the Prosecutor General of the Russian Federation,

Address: 15a, B. Dmitrovka Street, Moscow, 125993, Russia, GSP-3

25.09.2015 82/1-2791-15

To: Ministry of Internal Affairs of Ukraine

The Office of the Prosecutor General of the Russian Federation sends its compliments to the Ministry of Internal Affairs of Ukraine and informs that the requests for legal assistance sent by the Chief Investigative Department of the Ministry of Internal Affairs of Ukraine in connection with criminal case No. 120140000000290 have been examined.

The initiator of the requests asks that the following citizens of the Russian Federation be interrogated as witnesses: Verdiyana S.R., Siskevich I.E., Borisov P.G., Krylov N.E., Kuimov A.S., Stenov A.E. and Yamov N.E.

According to the results of the review the said requests were found lacking the description of the crime event of which the persons indicated in the petition were witnesses.

That is in contradiction with the requirements of Article 7(1)(h) of the Convention on Legal Aid and Legal Relations in Civil, Family and Criminal Cases of 22.01.1993, and makes it impossible to process the aforesaid requests for legal assistance.

In view of the above, the Office of the Prosecutor General of the Russian Federation returns the said requests to you without execution.

Annex: seven requests on 140 pages

Head, Administration for Legal Assistance, Chief Administration of International Legal Cooperation (signature) <...>

Executed by: <...>
Tel. (495) 982-41-55

(Stamp)
Office of the Prosecutor General of the Russian Federation
#82/1-2791-2015/HD32654-15

Annex 55

Letter from the Office of the Prosecutor-General of the Russian Federation No. 82/1-1897-17,
28 February 2019

(translation)

Translation**Letter from the Office of the Prosecutor General of the Russian Federation No. 82/1-1897-17, 28 February 2019.**

To: Office of the Prosecutor General of Ukraine,

Department of International Legal Cooperation,

Address: 13/15 Reznitskaya Street, Kyiv, 01011, Ukraine

28.02.2019 82/1-1897-17
14/3-25303-17

The Office of the Prosecutor General of the Russian Federation, in response to the request for legal assistance under criminal case No. 2201505000000021, reports the following.

For the reasons provided for in paragraph "b" of Article 2 of the European Convention on Mutual Assistance in Criminal Matters of 20.04.1959 and in Article 19 of the Convention on Legal Aid and Legal Relations in Civil, Family and Criminal Matters of 22.01.1993, the Russian Federation cannot comply with the request, because such compliance could damage the sovereignty and security of the Russian Federation, taking into account that <...>, a citizen of the Russian Federation, is a serviceman in the armed forces of the Russian Federation and in that capacity performs duties related to sovereign functions of the state in the sphere of defense and security.

Furthermore, the case in question bears the hallmarks of politically motivated persecution and poses a risk of violation of human rights.

Assisting such persecution would be incompatible with the international human rights obligations of the Russian Federation, in particular the right to a fair trial, thus contradicting the fundamental principles of the legislation of the Russian Federation, and could cause damage to its public order.

The Russian Federation objects to allegations that the Russian Federation is carrying out "occupation" and "armed aggression" against Ukraine, to which effect the Russian side has repeatedly made relevant statements.

Annex: request on 77 pages

Head, Legal Aid Directorate of the Chief Administration of International Legal Cooperation (signature) <...>

(Stamp) Office of the Prosecutor General of the Russian Federation
#82/1-1897дсп-2017/ИД7449-19

Annex 56

Letter from the Office of the Prosecutor-General of the Russian Federation No. 82/1-5598-17, 19
December 2018

(translation)

Translation**Letter from the Office of the Prosecutor General of the Russian Federation No. 82/1-5598-17, 19 December 2018.**

From: Office of the Prosecutor General of the Russian Federation,

Address: 15a, B. Dmitrovka Street, Moscow, 125993, Russia, GSP-3

To: International and Legal Cooperation Department,

Office of the Prosecutor General of Ukraine,

19.12.2018 82/1-5598-17
14/1/1-26307-17

Address: 13/15, Reznitskaya Street, Kyiv, 01011, Ukraine

The Office of the Prosecutor General of the Russian Federation, in response to the request of the Office of the Prosecutor General of Ukraine dated 05.12.2017 on the provision of legal assistance in criminal case No. 220150000000001, reports the following.

On the grounds set out in Article 2(b) of the European Convention on Mutual Assistance in Criminal Matters of 20.04.1959 and in Article 19 of the Convention on Legal Assistance and Legal Relations in Civil, Family and Criminal Matters of 22.01.1993, the Russian Federation cannot comply with the request, because the proceedings in question have the characteristics of politically motivated persecution and pose a threat in terms of human rights violations. Facilitating such persecution would not correspond to the international human rights obligations of the Russian Federation, in particular the right to a fair trial, thus contradicting the fundamental principles of the legislation of the Russian Federation, and could harm its public order. At the same time we draw the Ukrainian party's attention to the violation of norms of international law (Article 10 of the Convention on Legal Assistance and Legal Relations in Civil, Family and Criminal Matters of 22.01.1993 regarding service of documents, principles of territorial sovereignty and non-interference in internal affairs) as regards the direct postal and electronic transmission of procedural documents to G.L. Kornilov i.e. to the territory of the Russian Federation.

Annex: request on 14 pages

Head, Administration for Legal Assistance, Chief Administration of International Legal Cooperation (signature) <...>

Executed by: <...>
Tel. (495) 982-41-55

(Stamp)
Office of the Prosecutor General of the Russian Federation
#82/1-5598ДСП-2017/ИД44502-18

Annex 57

Letter from the Office of the Prosecutor-General of the Russian Federation No. 82/1-580-17,
22 June 2017

(translation)

Translation

Letter from the Office of the Prosecutor General of the Russian Federation No. 82/1-580-17, 22 June 2017.

From: Office of the Prosecutor General of the Russian Federation,

Address: 15a, B. Dmitrovka Street, Moscow, 125993, Russia, GSP-3

To: <...>,

Head of International Legal Cooperation and European Integration Administration,

22.06.2017 82/1-580-17
14/3-27044-16

Office of the Prosecutor General of Ukraine

Dear <...>,

The Office of the Prosecutor General of the Russian Federation reports that your request for legal assistance in criminal case #4201600000003990 has been considered.

It was established that the request in questions concerns criminal case #4201600000003990 of 19.12.2016.

At the same time, it follows from its content that pre-trial proceedings under criminal case No. 12014060020003033 are ongoing in relation to N.I. Kozitsyn, in which he is supposed to be served with a notice of suspicion of committing crimes and memos on the procedural rights and obligations of a suspect. However, no details of these criminal proceedings were provided in the request for legal assistance.

Besides, the submitted request lacks the connection between the description of the committed acts and their qualification, which does not meet the requirements of Art. 7(1)(g) of the Convention on Legal Assistance and Legal Relations in Civil, Family and Criminal Matters 1993, as well as Article 258-3 of the Criminal Code of Ukraine as "participation in a terrorist organisation".

The above-mentioned circumstances prevent the processing of the request at the present time.

Head, Administration for Legal Assistance, Chief Administration of International Legal Cooperation (signature) <...>

Executed by: <...>
Tel. (495) 982-41-55

(Stamp)
Office of the Prosecutor General of the Russian Federation
#82/1-580-2017/HD22873-17

Annex 58

Letter from the Office of the Prosecutor-General of the Russian Federation No. 82/1-3545-15, 11
February 2016

(translation)

Translation

Letter from the Office of the Prosecutor General of the Russian Federation No. 82/1-3545-15, 11 February 2016.

From: Office of the Prosecutor General of the Russian Federation,

Address: 15a, Bolshaya Dmitrovka, Moscow 125993, Russia, GSP-3

To: <...>

Head of International Legal Cooperation,

Office of the Prosecutor General of Ukraine

11.02.2016 82/1-3545-15
14/3-30877-15

Dear <...>,

The Office of the Prosecutor General of the Russian Federation presents its compliments to the Office of the Prosecutor General of Ukraine and informs that the request for the provision of legal assistance in connection with criminal case No. 12014030110000162 has been considered. The application includes a request to question as witnesses the Russian nationals named in the request.

In accordance with the requirements of Article 7(1)(d) of the Convention on Legal Aid and Legal Relations in Civil, Family and Criminal Cases dated 22.01.1993 and Article 14 (1)(d) of the European Convention on Mutual Assistance in Criminal Matters dated 20.04.1959, a request should specify the place of residence of witnesses and other persons, and in criminal cases - their place of birth as well.

The aforementioned information has not been provided in the submitted request, which makes execution thereof impossible at the present time.

Respectfully,

Head of the Legal Aid Administration,
Chief Administration of International Legal Cooperation (signature) <...>

Ex. <...>
Tel. (495) 982-41-55

Annex 59

Letter from the Office of the Prosecutor-General of the Russian Federation No. 82-1-2445-15,
17 February 2016

(translation)

Translation

Letter from the Office of the Prosecutor General of the Russian Federation No. 82/1-2445-15, 17 February 2016.

From: Office of the Prosecutor General of the Russian Federation,

Address: 15a, B. Dmitrovka Street, Moscow, 125993, Russia, GSP-3

To: <...>,

Head of International and Legal Cooperation Administration,

17.02.2016 82/1-2445-15
14/2/2-30679-15

Office of the Prosecutor General of Ukraine

Dear <...>,

The Office of the Prosecutor General of the Russian Federation presents its compliments to the Prosecutor General's Office of Ukraine and informs that the request for legal assistance in criminal case №220140000000328 has been considered.

It follows from the text of the request that on 24.02.2015, reports were filed putting the following officers of the Federal Security Service of the Russian Federation under suspicion of committing crimes: <...> - crimes under Article 27, part 3, Article 28, part 2 and Article 111, part 1 of the Criminal Code of Ukraine; <...>. - crimes under article 27, part 2; article 28, part 2; and article 111, part 1 of the Criminal Code of Ukraine.

The initiator requests that the above-mentioned persons be served with notices of suspicion. However, under the disposition of Article 111 (high treason) of the Criminal Code of Ukraine, only citizens of Ukraine may be recognised as perpetrators, which the officers of the Russian Federal Security Service are not.

In this regard, the Office of the Prosecutor General of the Russian Federation proposes providing us with necessary additional clarifications.

Head, Administration for Legal Assistance, Chief Administration of International Legal Cooperation
(signature) <...>

Executed by: <...>
Tel. (495) 982-41-55

Annex 60

All-Russian Population Information Classifier No. 018/2014

(excerpt, translation)

**Excerpt
Translation**

All-Russian Population Information Classifier No. OK 018/2014, available at: http://www.consultant.ru/document/cons_doc_LAW_181559/4bde797bdcec1c751aa426f4facc10f19143eed5/.

ConsultantPlus

! Amendment 21/2022 was put into effect with the right to early apply the same in legal relations arising from 8 September 2021.

**“OK 018-2014. All-Russian Classifier of Population Information”
(as adopted and adopted and put into effect by
Rosstandart Order No. 2019-st dated 12 December 2014)
(as amended on 30 August 2022)**

Facet 04. Languages of the Peoples of the Russian Federation and Foreign Languages

Facet 04 Languages of the Peoples of the Russian Federation and Foreign Languages

- 001 Abaza
- 002 Abkhazian
- 003 Avar
- 004 Agul
- 005 Adyghe
- 006 Adyghe
- 007 Azerbaijani
- 008 Aymara
- 009 Ainu
- 010 Alabuga-Tatar
- 011 Albanian
- 012 Aleutian
- 013 Altai
- 014 Aliutor
- 015 Amharic
- 016 English
- 017 Angolan
- 018 Andean
- 019 Arabic
- 020 Armenian
- 021 Archin
- 022 Assamese
- 023 Assyrian
- 024 Afar
- 025 Afrikaans
- 026 Akhvakh
- 027 Ashanti

028	Bagvalal
029	Bakwe
030	Balante
031	Balinese
032	Bamana
033	Bamileke
034	Bantu
035	Bartang
036	Basque
037	Baule
038	Bafut
039	Bashkir
040	Bezhita
041	Belarusian
042	Baloch
043	Belgian
044	Bemba
045	Bengal
046	Benin
047	Berber
048	Bethe
049	Burmese
050	Bihari
051	Bulgarian
052	Botlikh
053	Breton
054	Buryat
055	Vai
056	Welsh
057	Wakhi
058	Hungarian
059	Vepsian
060	Votic
061	Wolof
062	Vietnamese
063	Hawaiian
064	Gagauz
065	Haitian
066	Hinukh
067	Godoberi
068	Mountain Mari
069	Greek
070	Georgian
071	Guarani
072	Hunzib
073	Dagestanian
074	Dargin
075	Dari
076	Danish
077	Dahurian

078	Diula
079	Dolgan
080	Dungan
081	Hebrew
082	Zulu
083	Hebrew
084	Yiddish
085	Ido
086	Ingrian
087	Ingush
088	Indonesian
089	Interlingua
090	Inuit
091	Irish
092	Icelandic
093	Spanish
094	Italian
095	Itelmen
096	Ishkashim
097	Yoruba
098	Kabardian
099	Cape Verdean
100	Kazakh
101	Kalmyk
102	Cantonese
103	Karaite
104	Karakalpak
105	Karata
106	Karachay-Balkar
107	Karelian
107	Invalidated by ARCPI Amendment 1/2015 as approved by <i>Rosstandart</i> (click here to see the unamended text)
108	Kerek
109	Ket
110	Quechua
111	Kikuyu
112	Kyrgyz
113	Kistin
114	Chinese
115	Komi
116	Komi-Permyak
117	Congolese
118	Korean
119	Koryak
120	Kpelle
121	Creole
122	Creolean
123	Criolu
124	Crioluan
125	Kryts

126	Crimean Tatar
127	Krymchak
128	Qumanda
129	Kumyk
130	Kurdish
131	Khmer
132	Kipchak
133	Laz
134	Kal
135	Sri Lankan
136	Lao
137	Latin
138	Latvian
139	Lezgin
140	Lingala
141	Lithuanian
142	Meadow-Eastern Mari
143	Luxembourgish
144	Macedonian
145	Kashmiri

(No. 145 was introduced by ARCPI Amendment 1/2015 as approved by *Rosstandart*)

146	Malagasy
147	Malay
148	Malinke
149	Maldivian
150	Manden
151	Mansi
152	Manchurian
153	Maori
154	Mari
155	Maasai
156	Mingrelian
157	Mende
158	Moksha-Mordovian
159	Moldavian
160	Mongolian
161	Monegasque
162	Moore
163	Mordovian
164	Miao
165	Nama
166	Nanai
167	Nahuatl
168	Nganasan
169	Ndebele
170	Negidal
171	German
172	Nenets
173	Nepali
174	Nias

175	Nivkh
176	Nigerian
177	Dutch
178	Nogai
179	Nogai-Karagash
180	Norwegian
181	Nuba
182	Nuristani
183	Nyanja
184	Oromo
185	Oroch
186	Ossetian
187	Pakistani
188	Pamir
189	Punjabi
190	Papel
191	Persian
192	Polish
193	Portuguese
194	Pashto
195	Romansh
196	Rwanda
197	Romanian
198	Rusyn
199	Russian
200	Russian sign language of the deaf
201	Rutul
202	Rushan
203	Sami
204	Samoan
205	Sango
206	Sara
207	Svan
208	Selkup
209	Serbo-Croatian
210	Sesotho
211	Setswana
212	Simalur
213	Sinhalese
214	Sindhi
215	Sirenik
216	Slovak
217	Slovenian
218	Slovio
219	Somalia
220	Swahili
221	Surinamese
222	Tabasaran
223	Tagalog
224	Tajik

225	Thai
226	Talysh
227	Tamil
228	Tatar
229	Tat
230	Teleut
231	Temne
232	Tibetan
233	Tigre
234	Tigrinya
235	Tyndal
236	Tokpisin
237	Tongan
238	Tofalar
239	Tubalar
240	Tuvan
241	Turkish
242	Turkmen
243	Tho
244	Turkic
245	Udi
246	Udmurt
247	Udege
248	Uzbek
249	Uyghur
250	Uilta
251	Ukrainian
252	Olcha
254	Urdu
254	Fang
255	Fijian
256	Finnish
257	Fon
258	French
259	Frisian
260	Fula
261	Khakas
262	Khanty
263	Harari
264	Hausa
265	Khvarshin
266	Hindi
267	Hiri-motu
268	Tsakhur
269	Tsez
270	Romany
271	Chamalal
272	Chelkan
274	Chechen
274	Czech

275	Chuvash
276	Chukotka
277	Chulym-Turkic
278	Swedish
279	Shona
280	Shor
281	Shugnan
282	Ewe
28.4	Evenki
284	Even
285	Edo
286	Enets
287	Erzya-Mordovian
288	Eskimo
289	Esperanto
290	Estonian
291	Yugh
292	Yuit
293	Yukaghir
294	Yurt-Tatar
295	Yagnobi
296	Yazgulyam
297	Yakut
298	Japanese
299	Other languages

Annex 61

Code of Administrative Proceedings of the Russian Federation, 8 March 2015

(excerpt, translation)

**Excerpt
Translation**

Code of Administrative Proceedings of the Russian Federation, 8 March 2015, available at:

http://www.consultant.ru/document/cons_doc_LAW_176147/d53b6fc612510def4b17535a00dd5314b0c50d93/.

ConsultantPlus

**Code of Administrative Legal Proceedings of the Russian Federation
No. 21-FZ dated 8. March 2015
(as amended on 29 December 2022)
(with amendments effective from 1 January 2023)**

Article 12. Language of Administrative Legal Proceedings

1. Administrative legal proceedings shall be conducted in Russian as the state language of the Russian Federation. Administrative legal proceedings in federal courts of general jurisdiction located in a Republic forming part of the Russian Federation may also be conducted in the state language of that Republic.
2. The court shall explain to those persons involved in administrative legal proceedings but not speaking the language in which such proceedings are conducted that they shall have, and shall grant them, the right to familiarise themselves with the administrative case file, participate in such proceedings, make submissions, speak in the court, file petitions and complaints in their native language or a freely chosen language of communications, and make use of translation services in accordance with the procedures prescribed by this Code.
3. The judgment shall be set out in Russian and, upon request of either party to the administrative legal proceedings, shall also be translated into the language used in the proceedings.

Annex 62

Ministry of Education, Science and Youth of the Republic of Crimea, On the state of education in the state languages of the Republic of Crimea (Russian, Ukrainian, Crimean Tatar) and the study of native languages of the peoples of the Russian Federation living in the Republic of Crimea in general education institutions of the Republic of Crimea in the academic year 2021/2022

(translation)

Translation

Ministry of Education, Science and Youth of the Republic of Crimea, On the state of education in the state languages of the Republic of Crimea (Russian, Ukrainian, Crimean Tatar) and the study of native languages of the peoples of the Russian Federation living in the Republic of Crimea in general education institutions of the Republic of Crimea in the academic year 2021/2022, available at: https://monm.rk.gov.ru/uploads/txteditor/monm/attachments/d4/1d/8c/d98f00b204e9800998ecf8427e/php1laB0O_%D0%9D%D0%B0_%D1%81%D0%B0%D0%B9%D1%82%D0%B2_%D1%80%D0%B0%D0%B7%D0%B4%D0%B5%D0%BB%D0%93%D0%BE%D1%81%D1%8F%D0%B7%D1%8B%D0%BA%D0%B8.doc.

On the Status of Education in the State Languages of the Republic of Crimea (Russian, Ukrainian, and Crimean Tatar) and the Study of the Native Languages of the Peoples of the Russian Federation Living in the Republic of Crimea in General Educational Institutions in the Republic of Crimea in the 2021/2022 Academic Year

In accordance with Federal Law No. 317-FZ dated 03.08.2018 “On Amendments to Articles 11 and 14 of the Federal Law ‘On Education in the Russian Federation’”, **the language of education and the native language to be studied may be freely chosen from among the languages of the peoples of the Russian Federation**, including Russian as a native language, and the state languages of the Republics of the Russian Federation upon request of the parents (legal representatives) of minor students when being admitted (transferred) to training under preschool educational or state-accredited primary or basic general educational programmes.

The language of education for, and to be studied by, students shall be chosen by their parents (legal representatives) on a voluntary, free and informed basis; provided that such voluntariness shall not consist in a refusal to study the native language but in the possibility to choose the same (for example, from among those languages: Russian, Crimean Tatar, Ukrainian or other languages of the peoples of the Russian Federation living in the Republic of Crimea).

There are **545** general educational institutions teaching **224,600** students in the Republic of Crimea in the 2021/2022 academic year.

The education process shall be carried out in following three state languages of the Republic of Crimea: Russian, Ukrainian, and Crimean Tatar.

Education (Study) in Crimean Tatar

There are **16** general educational institutions instructing in Crimean Tatar (with **253** classes for **5,179** students), and **one** general educational institution instructing in Ukrainian (with **9** classes for **178** students):

1. Secondary School No. 18 instructing in Crimean Tatar in Yevpatoria, Republic of Crimea” (a municipal budgetary general educational institution);
2. Secondary School No. 42 named after Eshref Shemya-zade in Simferopol (a municipal budgetary general educational institution);

3. Secondary School No. 44 named after the Hero of the Russian Federation Alime Abdenanova in Simferopol (a municipal budgetary general educational institution);
4. Secondary School No. 3 instructing in Crimean Tatar in Sudak (a municipal budgetary general educational institution);
5. Bakhchisaray Secondary School No. 5 instructing in Russian and Crimean Tatar in Bakhchisaray (a municipal budgetary general educational institution);
6. Vilino Secondary School No. 2 instructing in Russian and Crimean Tatar the Bakhchisaray District (a municipal budgetary general educational institution);
7. Malovidnoye Secondary School in the Bakhchisaray District (a municipal budgetary general educational institution);
8. Belogorsk Secondary School No. 4 named after Bekir Choban-zade in Belogorsk (a municipal budgetary general educational institution);
9. Zuya Secondary School No. 2 named after Seitnafa Seitveliyev in the Belogorsk District (a municipal budgetary general educational institution);
10. Zarechnoye School and Kindergarten instructing in Crimean Tatar in the Dzhankoy District (a municipal budgetary general educational institution);
11. Maiskoye School instructing in Crimean Tatar in the Dzhankoy District (a municipal general educational institution);
12. Staryi Krym Secondary School No. 2 named after Double Hero of the Soviet Union Amet-Khan Sultan in the Kirovskoye District (a municipal budgetary general educational institution);
13. Oktyabrskoye School No. 3 name after Ismail Gasprinsky in the Krasnogvardeisky District (a municipal budgetary general educational institution);
14. Sary-Bash School named after A.M. Tipp instructing in Crimean Tatar in the Pervomaiskoye District (a municipal budgetary general educational institution);
15. Kolchugino School No. 2 instructing in Crimean Tatar in the Simferopol District (a municipal budgetary general educational institution); and
16. Sovetsky Secondary School No. 3 instructing in Crimean Tatar in the Sovetsky District (a municipal budgetary general educational institution).

In addition, **121** classes with instruction in Crimean Tatar have been opened (for **1,870** students) on the premises of the following **22** general educational institutions instructing in Russian:

1. Privetnenskoye School in Alushta (a municipal budgetary general educational institution);
2. Secondary School No 37. in Simferopol (a municipal budgetary general educational institution);
3. Gruzhevka Secondary School in Sudak (a municipal budgetary general educational institution);
4. Morskote Secondary School in Sudak (a municipal budgetary general educational institution);
5. School No. 15 in Feodosia (a municipal budgetary general educational institution);
6. Belogorsk Secondary School No. 3 in Belogorsk (a municipal budgetary general educational institution);
7. Zelenogorskoye Secondary School in the Belogorsk District (a municipal budgetary general educational institution);
8. Litvinenkovo Secondary School in the Belogorsk District (a municipal budgetary general educational institution);
9. Tsvetochnoye Secondary School in the Belogorsk District (a municipal budgetary general educational institution);

10. Mironovka School in the Dzhankoy District (a municipal budgetary general educational institution);
11. Zhuravki Secondary School in the Kirovskoye District (a municipal budgetary general educational institution);
12. Kraznoznamenka School in the Krasnogvardeisky District (a municipal budgetary general educational institution);
13. Beryozovka Secondary School in the Razdonloye District (a municipal budgetary general educational institution);
14. Zhuravli Secondary School in the Saki District (a municipal budgetary general educational institution);
15. Trudovoye Secondary School in the Saki District (a municipal budgetary general educational institution);
16. Denisovka School in the Simferopol District (a municipal budgetary general educational institution);
17. Dobroye Gymnasium School named after Y.A. Slonimsky in the Simferopol District (a municipal budgetary general educational institution);
18. Malenkoye School in the Simferopol District (a municipal budgetary general educational institution);
19. Teplovka School in the Simferopol District (a municipal budgetary general educational institution);
20. Urozhnayoye School named after K.V. Varlygin in the Simferopol District (a municipal budgetary general educational institution);
21. Ilyichyovo Secondary School in the Sovetsky District (a municipal budgetary general educational institution); and
22. Pushkino Secondary School in the Sovetsky District (a municipal budgetary general educational institution).

Education (Study) in Ukrainian

There is one general educational institution instructing in Ukrainian (in **9** classes for **178** students) functioning in the Republic of Crimea in the current academic year:

School No. 20 in Feodosia (a municipal budgetary general educational institution).

In addition, the Simferopol Academic School (a municipal budgetary general educational institution) in Simferopol offers classes with instruction in Ukrainian (**2** classes for **34** students).

Thus, **217,313** students (**96.8%** of the total number of students) are taught in Russian, **7,049** students in **374** classes (**3.1%**), in Crimean Tatar, and **212** students in **11** classes (**0.1%**), in Ukrainian in the current academic year.

Study of Native Languages

General educational institutions in the Republic of Crimea offer the study of the following **7** native languages of the peoples of the Russian Federation living in the Republic of Crimea are offered in the 2021/2022 academic year:

- Armenian (for **70** students);
- Bulgarian (for **48** students);
- Greek (for **211** students);

- Crimean Tatar (for **31,205** students);
- German (for **77** students);
- Russian (for **185,193** students); and
- Ukrainian (for **3,780** students).

Pre-school Education

554 educational institutions implementing pre-school educational programmes in the Republic of Crimea taught 73,900 children in the 2021/2022 academic year, of which 72,600 (98.3%) were taught in Russian, 1,400 (1.9%), in Crimean Tatar, and 93 (0.1%), in Ukrainian.

Annex 63

Ministry of Education, Science and Youth of the Republic of Crimea, Information on the Students Studying in the State Languages of the Republic of Crimea (Russian, Ukrainian, Crimean Tatar) in General Educational Institutions of the Republic of Crimea in the 2022/2023 School Year

(translation)

Translation

Ministry of Education, Science and Youth of the Republic of Crimea, Information on the Students Studying in the State Languages of the Republic of Crimea (Russian, Ukrainian, Crimean Tatar) in General Educational Institutions of the Republic of Crimea in the 2022/2023 School Year, available at:
https://monm.rk.gov.ru/uploads/txteditor/monm/attachments//d4/1d/8c/d98f00b204e9800998ecf8427e/phpLLvgNW_на%20САЙТ.doc.

**Information on the Students Studying in the State Languages
of the Republic of Crimea (Russian, Ukrainian, and Crimean Tatar)
in General Educational Institutions of the Republic of Crimea
in the 2022/2023 School Year**

In the 2022/2023 school year there are 545 general educational institutions teaching 230 300 students the Republic of Crimea.

The education process is carried out in three state languages of the Republic of Crimea: Russian, Ukrainian, and Crimean Tatar languages.

There are 528 general education institutions with Russian language of instruction ()

There are 16 general education institutions instructing in Crimean Tatar (in 261 classes for 5 462 students). In addition, 119 classes with instruction in Crimean Tatar (for 1 905 students) have been opened on the premises of 21 general education institutions instructing in Russian.

One general education institution (9 classes for 175 students) continues to instruct in Ukrainian. In addition, a class with instruction in Ukrainian (for 15 students) has been opened on the premises of the Simferopol Academic Gymnasium in Simferopol.

Thus, there are 222 800 students studying in Russian (96.7% of the total number of students), 7 300 students studying in Crimean Tatar (3.2%), and 197 students studying in Ukrainian (0.1%).

In the 2022/2023 school year seven native languages of the peoples of the Russian Federation living in the Republic of Crimea will be taught and studied in the general education institutions of the Republic of Crimea:

- Armenian (134 students),
- Bulgarian (49 students),
- Greek (142 students);
- Crimean Tatar (33 351 students),
- German (117 students),
- Russian (178 454 students),
- Ukrainian (3 486 students).

In the 2022/2023 school year, in 562 educational institutions of the Republic of Crimea which implement programmes of preschool education, there are 78 600 children, including 72 600 taught in Russian (98.33 %), 1 300 in Crimean Tatar (1.63 %) and 31 in Ukrainian (0.04 %).

Annex 64

Crimean Federal University, *Allocation of budgetary places in the bachelor's and specialist's programme in 2023 (full-time programmes)*

(translation)

Translation

Crimean Federal University, Allocation of budgetary places in the bachelor's and specialist's programme in 2023 (full-time programmes), available at: <https://priem.cfuv.ru/bachelor/direction/cfu>.



ADMISSION COMMITTEE
V.I. VERNADSKY CRIMEAN FEDERAL UNIVERSITY

ALLOCATION OF STATE-FUNDED PLACES IN THE BACHELOR'S AND SPECIALIST'S PROGRAMMES IN 2023

Admission will be according to the competitive entry groups

<u>Full-time education</u>						
Field of study (major)	Total full-time places - state-funded	Including privileged persons	Special quota	Employer-funded places	Detailed employer-funded admission quota	Total full-time places - fee-paying
01.03.01 Mathematics (Mathematical methods of digital technologies in DataScience) (https://cloud.cfuv.ru/index.php/s/SxG2tScXP5nGWN5)	25	3	3			5
01.03.02 Applied mathematics and computer science (Mathematical support and software for artificial intelligence systems) (Augmented and virtual reality methods and technologies) (https://cloud.cfuv.ru/index.php/s/NoqEqsKyWTtyAoM)	50	5	5			10
03.03.02 Physics (Modern physics technologies) (https://cloud.cfuv.ru/index.php/s/5RGn6XKeMY2ePP9)	20	2	2			5
03.03.03 Radiophysics (Computer-aided information communication technologies) (https://cloud.cfuv.ru/index.php/s/KZACNe3RQcMz9PJ)	20	2	2			5

04.03.01 Chemistry (Modern aspects of Chemistry) (https://cloud.cfuv.ru/index.php/s/ZDTyd9mpYWbozjk)	39	4	4			11
05.03.02 Geography (Theory and practice of Geography) (https://cloud.cfuv.ru/index.php/s/8NxaiqentFpf84F)	20	2	2			5
05.03.06 Ecology and natural resources management (Geoecology and sustainable nature management) (Biological safety and Environmental protection) (https://cloud.cfuv.ru/index.php/s/KF82mbJ4AgZ6atw)	30	3	3			5
06.03.01 Biology (Modern aspects of Biology) (https://cloud.cfuv.ru/index.php/s/xCMMWTn8CnLmTPM)	58	6	6			2
07.03.04 Urban planning (Urban planning design) (https://cloud.cfuv.ru/index.php/s/ktBe2xLTj2CrzPb)	50	5	5			10
08.03.01 Civil engineering (Industrial and civil engineering) (Production and application of building materials, products and structures) (Utility systems in construction) (Real property expert assessment and management) https://cloud.cfuv.ru/index.php/s/Es4BRKSWqFrgDQR	100	10	10			20
09.03.01 Computer science and computing machines (Computer science and computing machines) https://cloud.cfuv.ru/index.php/s/iPWx5Y3Q8LcgApj	50	5	5			10
09.03.04 Software Engineering Software Engineering https://cloud.cfuv.ru/index.php/s/NNM6REWsWd78nrH	75	8	8			15
13.03.02 Electrical power engineering and equipment (Electric power supply for industrial facilities, urban and rural communities) https://cloud.cfuv.ru/index.php/s/gM4GZZ	25	3	3			5

386rxNem6						
16.03.01 Technical physics (Functional materials) https://cloud.cfuv.ru/index.php/s/p7NtGCPaAFA7qC3	25	3	3			5
19.03.02 Food products from vegetable raw materials (Fermentation and winemaking technology) (Essential oils and perfumery/cosmetic product technology) https://cloud.cfuv.ru/index.php/s/nFXeCH8aKApCFed	37	4	4			10
19.03.03 Food product of animal origin (Milk and dairy product technology) https://cloud.cfuv.ru/index.php/s/wKKG4YbztN5sw8d	13	2	1			5
20.03.02 Environmental management and water use (Irrigation, land reclamation and protection) https://cloud.cfuv.ru/index.php/s/rRj7JrELkjCSNA9	17	2	2			5
21.03.02 Land management and cadastres (Land management and cadastres) https://cloud.cfuv.ru/index.php/s/moyJWb33dmykF4A	25	3	3			5
21.03.03 Geodetics and remote sounding (Geodetics) https://cloud.cfuv.ru/index.php/s/esNfs43XkSmdF6j	25	3	3			5
27.03.03 System analysis and management (Automated data processing systems and management) https://cloud.cfuv.ru/index.php/s/PLD7ZZ7R2xBDrD4	25	3	3			5
35.03.01 Forestry (Forestry) https://cloud.cfuv.ru/index.php/s/nXMrxfsbDZqiwsT	20	2	2			5
35.03.04 Agronomics (Agronomics) https://cloud.cfuv.ru/index.php/s/YAeraRWWsb6Ze42	20	2	2			5
35.03.05 Horticulture (Fruit/vegetable)	20	2	2			5

farming and viticulture) https://cloud.cfuv.ru/index.php/s/9RpcnY83f8GoWe6						
35.03.06 Agro-engineering (Robotic agricultural production systems) (Agro-engineering) https://cloud.cfuv.ru/index.php/s/gi4mQTiLcRGQZq4	40	4	4			5
35.03.10 Landscape architecture (Gardening and landscape design) https://cloud.cfuv.ru/index.php/s/dEtK5B3cr4FkDDW	25	3	3			5
37.03.01 Psychology (Psychology) https://cloud.cfuv.ru/index.php/s/dzGtcB26kxLQbbD	40	4	4			20
38.03.01 Economics. (Banking and financial services) (Accounting, analysis and audit) (Foreign trade activities) (State and municipal finances) (Economics of enterprises and organisations) https://cloud.cfuv.ru/index.php/s/spdMSGxELcaAyKG	120	12	12			30
38.03.02 Management. (Management of organisations) https://cloud.cfuv.ru/index.php/s/G6nj3jkPZqANQMQ	48	5	5			10
38.03.03 Personnel Management. (Human resources management and labour economics) https://cloud.cfuv.ru/index.php/s/p929tTfGDwdw7P	24	3	2			5
38.03.04 Public and Municipal Administration. (Public and municipal administration) https://cloud.cfuv.ru/index.php/s/E8g5nritRncEkgy	48	5	5			10
38.03.05 Business informatics (Digital economy analysis technologies) https://cloud.cfuv.ru/index.php/s/64BnRFwRm79AjjW	25	3	3			5
38.03.06 Trading business (Marketing, trading and purchasing business) https://cloud.cfuv.ru/index.php/s/C7cRg4Nfb3XZMtT	25	3	3			5

40.03.01 Jurisprudence (Jurisprudence) https://cloud.cfuv.ru/index.php/s/AMNzLtPWxpGYMQD	50	5	5			75
41.03.04 Political science (Political science) https://cloud.cfuv.ru/index.php/s/gTi8pWYi9Zsc5KL	21	3	2			5
42.03.01 Advertising and public relations (Advertising and public relations) (Marketing and business communications on the Internet and in mass media) https://cloud.cfuv.ru/index.php/s/GCRHMcZaMEjFr6s	14	2	1			45
42.03.02 Journalism (New Media) https://cloud.cfuv.ru/index.php/s/CBXPkajWrWR7FnM	14	2	1			15
42.03.03 Publishing* (Media industry) https://cloud.cfuv.ru/index.php/s/6x9tgkW26yJ99fw	20	2	2			5
43.03.02 Tourism (Tourism business) https://cloud.cfuv.ru/index.php/s/ZZSbfsQkLtSmg69	50	5	5			10
43.03.03 Hotel business (Hotel business) https://cloud.cfuv.ru/index.php/s/KMCRRYWoYoko7Yf	25	3	3			5
45.03.01 Philology. https://cloud.cfuv.ru/index.php/s/DDeTfBgkc4zk88b (Russian language and literature)	60	6	6			35
45.03.01 Philology. https://cloud.cfuv.ru/index.php/s/DDeTfBgkc4zk88b (Crimean Tatar language and literature. Second language (English / German/ French / Spanish / Arabic / Turkish / Persian / Ukrainian / Russian)	13	2	1			
45.03.01 Philology. https://cloud.cfuv.ru/index.php/s/DDeTfBgkc4zk88b (Ukrainian language and literature. Second language (English / French / German / Modern Greek / Spanish / Arabic / Turkish / Persian / Russian / Crimean Tatar)	12	2	1			

45.03.01 Philology. https://cloud.cfuv.ru/index.php/s/DDeTfBgkc4zk88b (English language and literature. Second language (German / French / Modern Greek / Spanish / Arabic / Turkish / Persian / Ukrainian / Crimean Tatar))	45	5	5			
45.03.01 Philology. https://cloud.cfuv.ru/index.php/s/DDeTfBgkc4zk88b (German language and literature). Second language (English / French / Modern Greek / Spanish / Arabic / Turkish / Persian / Ukrainian / Crimean Tatar)	23	3	2			
45.03.01 Philology. https://cloud.cfuv.ru/index.php/s/DDeTfBgkc4zk88b (French language and literature. Second language (English / German / Modern Greek / Spanish / Arabic / Turkish / Persian / Ukrainian / Crimean Tatar))	22	3	2			
46.03.01 History (History) https://cloud.cfuv.ru/index.php/s/9j2Lst6MB7Hbr5G	50	5	5			10
46.03.02 Documentation and archival science (Documentation support for management) https://cloud.cfuv.ru/index.php/s/s7PHSmNMe76WDeB	25	3	3			5
47.03.01 Philosophy (Social and humanitarian technologies) https://cloud.cfuv.ru/index.php/s/bFE7rFCBgHQf7Qs	13	2	1			5
47.03.03 Religious studies (Religious studies) https://cloud.cfuv.ru/index.php/s/2ijWcH3oMb9TKy2	13	2	1			5
49.03.01 Physical education (Physical education and sports coaching technologies) https://cloud.cfuv.ru/index.php/s/srLzjWax2XHRrSe	25	3	3			5
49.03.02 Physical education for persons with disabilities (adaptive physical education) (Physical education for persons with disabilities (adaptive physical education)) https://cloud.cfuv.ru/index.php/s/JbYjRyY	25	3	3			5

PT9FyH88					
51.03.01 Cultural studies (Cultural studies) https://cloud.cfuv.ru/index.php/s/2YPrtGk267Cbr2Q	14	2	1		5
31.05.01 General medicine (General medicine) (General medicine (taught in English)) https://cloud.cfuv.ru/index.php/s/zGqqCQncHypi59B	323	33	32		770
31.05.02 Pediatrics (Pediatrics) https://cloud.cfuv.ru/index.php/s/ZoBRE7tK6GZSZNJ	98	10	10		50
31.05.03 Dentistry (Dentistry) https://cloud.cfuv.ru/index.php/s/3Yk2BfrGWm7Qt5c	23	3	2		130
33.05.01 Pharmacy (Modern aspects of pharmacy) https://cloud.cfuv.ru/index.php/s/ykkkDp7yqLTrLiR	28	3	3		2
36.05.01 Veterinary medicine (Veterinary medicine) https://cloud.cfuv.ru/index.php/s/4mMJeJyqjCd9Xn9	75	8	8		15
54.05.03 Graphic art (Animation and computer graphics artist) https://cloud.cfuv.ru/index.php/s/wcGLB29CLGQNdEZ	23	3	2		15

Extramural education

Part-time education

List of admission exams by competitive admission groups (/bachelor/entrance-exams)

Contacts

Address: 4 Academy Member Vernadsky Avenue, Simferopol, 295007, Republic of Crimea

(<https://yandex.ru/maps/-/CBe5JZB9tD>)

Open hours: Mon-Fri 9:00 - 16:00

Phone: 8(3652)51-65-65

Our social network: <https://vk.com/pkcfu>

Branches

The Humanitarian and Pedagogical Academy at the V.I. Vernadsky CFU
(<http://gpa.cfuv.ru/>)

The Yevpatoria Institute of Social Sciences at the V.I. Vernadsky CFU
(<http://eism.cfuv.ru/>)

The Pedagogical Education and Management Institute at the V.I. Vernadsky CFU
(<http://ipomkfu.ru/>)

The Sevastopol Economic and Humanitarian Institute at the V.I. Vernadsky CFU
(<http://segi.cfuv.ru/>)

Annex 65

Crimean Federal University, *Allocation of budgetary places in the bachelor's and specialist's programme in 2023 (extramural programmes)*

(translation)

Translation

Crimean Federal University, Allocation of budgetary places in the bachelor's and specialist's programme in 2023 (extramural programmes), available at: <https://priem.cfuv.ru/bachelor/direction/cfu>.



ADMISSION COMMITTEE
V.I. VERNADSKY CRIMEAN FEDERAL UNIVERSITY

ALLOCATION OF STATE-FUNDED PLACES IN THE BACHELOR'S AND SPECIALIST'S PROGRAMMES IN 2023

Admission will be according to the competitive entry groups

Full-time education					
Extramural education					
Field of study (major)	Total extramural places – state-funded	Including privileged persons	Special quota	Employer-funded places	Total extramural places – fee-paying
09.03.01 Computer science and computing machines (Computer science and computing machines) https://cloud.cfuv.ru/index.php/s/iPWx5Y3Q8LcgApj	25	3	3		5
19.03.02 Food products from vegetable raw materials (Fermentation and winemaking technology) (Essential oils and perfumery/cosmetic product technology) https://cloud.cfuv.ru/index.php/s/nFXeCH8aKApCFed	13	2	1		10
19.03.03 Food product of animal origin (Milk and dairy product technology) https://cloud.cfuv.ru/index.php/s/wKKG4YbztN5sw8d	12	2	1		10
21.03.02 Land management and cadastres (Land management and cadastres) https://cloud.cfuv.ru/index.php/s/moyJWb33dmykF4A	25	3	3		5
35.03.04 Agronomics	17	2	2		5

(Agronomics) https://cloud.cfuv.ru/index.php/s/YAeraRWWsb6Ze42					
35.03.05 Horticulture (Fruit/vegetable farming and viticulture) https://cloud.cfuv.ru/index.php/s/9RpcnY83f8GoWe6	16	2	2		5
35.03.06 Agro-engineering (Robotic agricultural production systems) (Agro-engineering) https://cloud.cfuv.ru/index.php/s/gi4mQTiLcRGQZq4	17	2	2		5
40.03.01 Jurisprudence (Jurisprudence) https://cloud.cfuv.ru/index.php/s/AMNzLtPWxpGYMQD					20
43.03.02 Tourism (Tourism business) https://cloud.cfuv.ru/index.php/s/ZZSbfsQkLtsmg69	12	2	1		15
43.03.03 Hotel business (Hotel business) https://cloud.cfuv.ru/index.php/s/KMCrRYWoYoko7Yf	13	2	1		15
45.03.01 Philology. https://cloud.cfuv.ru/index.php/s/DDeTfBgkc4zk88b (Russian language and literature)	10	1	1		10
45.03.01 Philology. https://cloud.cfuv.ru/index.php/s/DDeTfBgkc4zk88b (Crimean Tatar language and literature. Second language (English / German/ French / Spanish / Arabic / Turkish / Persian / Ukrainian / Russian)	10	1	1		
46.03.02 Documentation and archival science (Documentation support for management) https://cloud.cfuv.ru/index.php/s/s7PHSmNMe76WDeB	20	2	2		5
49.03.01 Physical education (Physical education and sports coaching technologies) https://cloud.cfuv.ru/index.php/s/srLzjWax2XHrRse	20	2	2		5

Part-time education

List of admission exams by competitive admission groups (/bachelor/entrance-exams)

Contacts

Address: 4 Academy Member Vernadsky Ave., Simferopol, 295007, Republic of Crimea
(<https://yandex.ru/maps/-/CBe5JZB9tD>)

Open hours: Mon-Fri 9:00 - 16:00

Branches

The Humanitarian and Pedagogical Academy at the V.I. Vernadsky CFU
(<http://gpa.cfuv.ru/>)

The Yevpatoria Institute of Social Sciences at the V.I. Vernadsky CFU
(<http://eisn.cfuv.ru>)

The Pedagogical Education and Management Institute at the V.I. Vernadsky CFU
(<http://ipomkfu.ru>)

The Sevastopol Economic and Humanitarian Institute at the V.I. Vernadsky CFU
(<http://segi.cfuv.ru/>)

Annex 66

Crimean Engineering and Pedagogical University, *Number of places for admission for the
2023/2024 academic year*

(translation)

Translation

Crimean Engineering and Pedagogical University, Number of places for admission for the 2023/2024 academic year, available at: <https://kipu-rc.ru/downloads/2022/priem/11.pdf>.

Field of study (major)	Fevzi Yakubov Crimean Engineering and Pedagogical University, number of places for admission for the 2023/2024 academic year						List of Unified State Exams and admission tests for applicants with a general secondary or higher education	List of admission tests for applicants with a secondary vocational education
	full-time education		part-time education		extramural education			
	state-funded	fee-paying	state-funded	fee-paying	state-funded	fee-paying		
BACHELOR'S PROGRAMMES								
09.03.03 Applied computer science Major: Applied computer science in IT	40	25	-	-	-	25	Mathematics (major) Computer science & ICT or Physics Russian language Mathematics (major) Computer science & ICT or Physics Russian language Mathematics (major) Computer science & ICT or Physics Russian language Mathematics (major)	Fundamentals of algorithmisation and programming Computer architecture Russian language Materials science Material processing technologies Russian language Materials science Material processing technologies Russian language Materials science
15.03.01 Mechanical engineering. Major: Electromechanics and welding	25	10	-	-	10	25	Computer science & ICT or Physics Russian language Mathematics (major)	Material processing technologies Russian language Materials science
15.03.05 Process design support of mechanical engineering facilities "Broad coverage programme"	25	10	-	-	10	25	Computer science & ICT or Physics Russian language Mathematics (major)	Material processing technologies Russian language Materials science
20.03.01 Human-made environment safety Major: Process safety	25	10	-	-	10	25	Computer science & ICT or Physics Russian language Mathematics (major)	Occupational safety Russian language Fundamentals of safety
23.03.03 Operation of transportation and process machines and packages Major: Automobiles and automotive industry	25	10	-	-	10	25	Computer science & ICT or Physics Russian language Mathematics (major)	Russian language Automobile design Automobile maintenance and repair
37.03.01 Psychology. "Broad coverage programme"	40	25	10	10	-	-	Russian language Social science Biology	Russian language Fundamentals of the State and society General pedagogy

38.03.01 Economics. Major: Accounting, analysis and audit	25	25	-	-	-	-	-	-	Russian language	Russian language	Russian language
									Mathematics (major) Social science or History	Mathematics (major) Social science or History	Economics Fundamentals of entrepreneurship
38.03.01 Economics. Major: Global economy	25	25	-	-	-	-	-	-	Russian language	Russian language	Russian language
									Mathematics (major) Social science or History	Mathematics (major) Social science or History	Economics Fundamentals of entrepreneurship
38.03.01 Economics. Major: Taxes and taxation	25	25	-	-	-	-	-	-	Russian language	Russian language	Russian language
									Mathematics (major) Social science or History	Mathematics (major) Social science or History	Economics Fundamentals of entrepreneurship
38.03.01 Economics. Major: Digital economy	25	25	-	-	-	-	-	-	Russian language	Russian language	Russian language
									Mathematics (major) Social science or History	Mathematics (major) Social science or History	Economics Fundamentals of entrepreneurship
38.03.02 Management. Major: Management (hotel, resort and tourism business)	25	25	-	-	-	-	-	-	Russian language	Russian language	Russian language
									Mathematics (major) Social science or History	Mathematics (major) Social science or History	Economics Fundamentals of entrepreneurship
38.03.02 Management. Major: Logistics and supply chain management	25	25	-	-	-	-	-	-	Russian language	Russian language	Russian language
									Mathematics (major) Social science or History	Mathematics (major) Social science or History	Economics Fundamentals of entrepreneurship
42.03.02 Journalism “Broad coverage programme”	20	25	-	-	-	-	-	-	Russian language	Russian language	Russian language
									Literature	Literature	Fundamentals of journalism Creative test (essay)
44.03.01 Pedagogical education. Major: Technology	15	10	-	-	-	-	-	-	Russian language	Russian language	Russian language
									Social science	Social science	Fundamentals of the State and society
44.03.01 Pedagogical education. Major: Primary education	25	25	-	-	-	-	-	-	Biology	Biology	General pedagogy
									Russian language	Russian language	Russian language
44.03.01 Pedagogical education. Major: Preschool education	25	25	-	-	-	-	-	-	Russian language	Russian language	Russian language
									Social science	Social science	Fundamentals of the State and society

44.03.01 Pedagogical education. Major: Biology	15	10	-	-	-	-	-	-	-	-	Biology	General pedagogy
											Russian language Social science	Russian language Fundamentals of the State and society
44.03.01 Pedagogical education. Major: Chemistry	15	10	-	-	-	-	-	-	-	-	Biology	General pedagogy
											Russian language Social science	Russian language Fundamentals of the State and society
44.03.01 Pedagogical education. Major: Mathematics	20	10	-	-	-	-	-	-	-	-	Chemistry or Biology Russian language	General pedagogy Russian language
											Social science	Fundamentals of the State and society
44.03.01 Pedagogical education. Major: Computer Science	15	10	-	-	-	-	-	-	-	-	Mathematics (major) or Computer science & ICT	General pedagogy
											Russian language Social science	Russian language Fundamentals of the State and society
44.03.01 Pedagogical education. Major: Physics	15	10	-	-	-	-	-	-	-	-	Computer science & ICT or Mathematics (major)	General pedagogy
											Russian language Social science	Russian language Fundamentals of the State and society
44.03.01 Pedagogical education. Major: Musical education	20	10	-	-	-	-	-	-	-	-	Physics or Mathematics (major)	General pedagogy
											Russian language Social science	Russian language Fundamentals of the State and society
44.03.01 Pedagogical education. Major: Safe living	20	10	-	-	-	-	-	-	-	-	Creative test Russian language	General pedagogy Russian language
											Social science	Fundamentals of the State and society
44.03.03 Education of handicapped persons. Major: Education of oligophrenics	15	25	-	-	-	-	-	-	-	-	Proficiency test Russian language	General pedagogy Russian language
											Social science	Fundamentals of the State and society
44.03.03 Education of handicapped persons. Major: Speech-language	30	25	-	-	-	-	-	-	-	-	Biology Russian language	General pedagogy Russian language
											Social science	Fundamentals of the State and society

therapy											Biography	General pedagogy
											Russian language	Russian language
44.03.04 Vocational training (by industry). Major: Decorative and applied art and design, Major: Fashion technology and design	25	10	-	-	10	10	10	-	10	10	Mathematics (major) Proficiency test (Product design)	Specialist's targeted career Proficiency test (Product design)
											Russian language	Russian language
45.03.01 Philology. Major: Teaching of linguistics disciplines (Crimean Tatar language and literature, English language and literature)	15	10	-	-	10	10	10	-	10	10	Proficiency test (Crimean Tatar language)	Proficiency test (Crimean Tatar language)
											Russian language	Russian language
45.03.01 Philology. Major: Teaching of linguistics disciplines (Crimean Tatar language and literature, Russian language and literature)	15	10	-	-	10	10	10	-	10	10	Literature	Fundamentals of the State and society
											Russian language	Fundamentals of the State and society
45.03.01 Philology. Major: Teaching of linguistics disciplines (Crimean Tatar language and literature, Turkish language and literature)	10	10	-	-	10	10	10	-	10	10	Proficiency test (Crimean Tatar language)	Proficiency test (Crimean Tatar language)
											Russian language	Russian language
45.03.01 Philology. Major: Teaching of linguistics disciplines (English language and literature, Russian language and literature)	10	10	-	-	10	10	10	-	10	10	Literature	Fundamentals of the State and society
											Russian language	Fundamentals of the State and society
45.03.01 Philology. Major Philology of foreign languages (English language and literature, German language and literature)	20	10	-	-	10	10	10	-	10	10	Proficiency test (English language)	Proficiency test (English language)
											Russian language	Russian language
45.03.01 Philology. Major: Teaching of linguistics disciplines (Russian language and literature, Ukrainian language and literature)	10	10	-	-	10	10	10	-	10	10	Literature	Fundamentals of the State and society
											Russian language	Fundamentals of the State and society
46.03.01 History, "Broad coverage programme"	25	10	-	-	10	10	10	-	10	10	Proficiency test (Ukrainian language)	Proficiency test (Ukrainian language)
											Russian language	Russian language
											History	History of global and Russian civilization
											Social science	Fundamentals of the State and society

20.04.01 Human-made environment safety Master's program "Human-made environment safety. Occupational Health and Safety"	10	10	-	-	-	-	-	-	Comprehensive proficiency test
23.04.03 Operation of transportation and process machines and packages Master's program "Automobile transport maintenance and operation"	10	10	-	-	-	-	-	-	Comprehensive proficiency test
37.04.01 Psychology. Master's programme "Developmental psychology, age psychology"	-	-	10	10	-	-	10	-	Comprehensive proficiency test
37.04.01 Psychology. Master's program "Social Psychology"	10	10	-	-	-	-	-	-	Comprehensive proficiency test
38.04.01 Economics. Master's program "Accounting, Analysis and Audit"	10	10	-	-	-	-	-	10	Comprehensive proficiency test
38.04.01 Economics. Master's program "Global Economy and International Economic Relations"	10	10	-	-	-	-	-	10	Comprehensive proficiency test
38.04.01 Economics. Master's program "Tax Administration and Consulting"	10	10	-	-	-	-	-	10	Comprehensive proficiency test
38.04.02 Management. Master's programme "Production management"	10	10	-	-	-	-	-	10	Comprehensive proficiency test
42.04.02 Journalism. Master's programme "Journalism and media communication in a multicultural society"	10	10	-	-	-	-	-	-	Comprehensive proficiency test
44.04.01 Pedagogical education. Master's programme "Primary education"	10	10	-	-	-	-	10	10	Comprehensive proficiency test
44.04.01 Pedagogical education. Master's programme "Management of preschool education"	10	10	-	-	-	-	10	10	Comprehensive proficiency test
44.04.01 Pedagogical education. Master's programme "Methodology guidance in preschool education"	10	10	-	-	-	-	10	10	Comprehensive proficiency test
44.04.01 Pedagogical education. Master's programme "Computer	10	10	-	-	-	-	-	-	Comprehensive proficiency test

science and IT in education"																								
44.04.01 Pedagogical education. Master's programme "Health and safety management"	10	10	-	-	-	-	-	-	-	10	-	-	-	-	-	10	-	-	10	Comprehensive proficiency test				
44.04.01 Pedagogical education. Master's programme "Music education"	-	-	-	-	-	-	-	-	-	10	10	10	15	15	10	10	-	-	10	Comprehensive proficiency test				
44.04.03 Education of handicapped persons. Master's program "Psychological and pedagogical guidance for education of persons with disabilities"	10	10	-	-	-	-	-	-	-	10	10	15	15	10	10	10	-	-	10	Comprehensive proficiency test				
44.04.01 Vocational training (by industry). Master's programme "Strategic management and innovation in education"	-	-	-	-	-	-	-	-	-	10	-	10	10	10	10	10	-	-	10	Comprehensive proficiency test				
44.04.01 Vocational training (by industry). Master's programme "Technology and design of light industry products"	10	10	-	-	-	-	-	-	-	10	10	-	-	-	-	-	-	-	10	Comprehensive proficiency test				
45.04.01 Philology. Master's programme "Theory of translation and intercultural communication"	10	10	-	-	-	-	-	-	-	10	10	10	10	10	10	10	-	-	10	Comprehensive proficiency test				
45.04.01 Philology. Master's programme "Modern discourse of philological educational environment"	10	10	-	-	-	-	-	-	-	10	10	10	10	10	10	10	-	-	10	Comprehensive proficiency test				
45.04.01 Philology. Master's programme "Theoretical and practical aspects of Crimean Tatar philology"	10	10	-	-	-	-	-	-	-	10	10	-	-	-	10	10	-	-	10	Comprehensive proficiency test				
46.04.01 History. Master's programme "National history"	10	10	-	-	-	-	-	-	-	10	10	10	10	10	10	10	-	-	10	Comprehensive proficiency test				
53.04.01 Musical instrument art. Master's program "National musical instruments of the peoples of Russia"	10	10	-	-	-	-	-	-	-	10	10	10	10	10	10	10	-	-	10	Comprehensive proficiency test				
53.04.04 Conducting. Master's programme "Conducting an academic choir"	10	10	-	-	-	-	-	-	-	10	10	10	10	10	10	10	-	-	10	Comprehensive proficiency test				
54.04.02 Decorative and applied arts and crafts. Master's programme	10	10	-	-	-	-	-	-	-	10	10	10	10	10	10	10	-	-	10	Comprehensive proficiency test				

									"Decorative art in the context of national cultural heritage"
--	--	--	--	--	--	--	--	--	---

Annex 67

The Council of Ministers of the Republic of Crimea. Decree No. 658 “On Approval of the Regulations on the Remuneration System for Employees of State Budgetary and Autonomous Educational Organizations of the Republic of Crimea”, 30 December 2014

(translation)

Translation

The Council of Ministers of the Republic of Crimea. Decree No. 658 “On Approval of the Regulations on the Remuneration System for Employees of State Budgetary and Autonomous Educational Organizations of the Republic of Crimea”, 30 December 2014, available at: <https://rk.gov.ru/ru/document/show/736>.

**RESOLUTION OF
THE COUNCIL OF MINISTERS OF THE REPUBLIC OF CRIMEA
No. 658 dated 30 December 2014**

On the Approval of the Regulation on the Labour Compensation System for the Employees of State Budgetary and Autonomous Educational Institutions in the Republic of Crimea

In accordance with Article 144 of the Labour Code of the Russian Federation, Article 41 of the Law of the Republic of Crimea No. 5-ZRK dated 29 May 2014 “On the System of State Executive Bodies of the Republic of Crimea”, Article 1 of the Law of the Republic of Crimea No. 14-ZRK/2014 dated 28 November 2014 “On Labour Compensation for the Employees of State Institutions of the Republic of Crimea”, the Council of Ministers of the Republic of Crimea **hereby resolves** that:

1. The Regulation on the Labour Compensation System for the Employees of State Budgetary and Autonomous Educational Institutions in the Republic of Crimea (the “Regulation”) as attached hereto be approved.
2. The costs to pay wages and salaries to the employees of state budgetary and autonomous educational institutions in the Republic of Crimea shall be financed within the limits of the budget allocations made, budget liabilities of the Republic of Crimea and proceeds from other income-generating activities.
3. The Ministry of Education, Science and Youth of the Republic of Crimea shall:
 - 3.1. ensure that the state budgetary and autonomous educational institutions in the Republic of Crimea co-ordinate their efforts to implement the Regulation; and
 - 3.2. ensure that the compliance with the terms of labour compensation for the employees of state budgetary and autonomous educational institutions in the Republic of Crimea is monitored.
4. The heads of the state budgetary and autonomous educational institutions shall bring the terms of labour compensation for the employees of state budgetary and autonomous educational institutions in compliance with the Regulation within three months of the official publication of this Resolution.
5. A. Pashkunova, Deputy Chair of the Council of Ministers of the Republic of Crimea, shall be entrusted with monitoring the implementation of this Resolution.
6. This Resolution shall become effective on 1 January 2015.

S. AKSYONOV,
Head of the Republic of Crimea and
Chair of the Council of Ministers of the Republic of Crimea

L. OPANASYUK,
Deputy Chair of the Council of Ministers of the Republic of Crimea and
Chief of Staff of the Council of Ministers of the Republic of Crimea

Appendix to Resolution of the Council
of Ministers of the Republic of Crimea
No. 658 dated 30 December 2014

**Regulation on the Labour Compensation System for the Employees of State Budgetary
and Autonomous Educational Institutions in the Republic of Crimea**

1. General

- 1.1. This Regulation shall govern the legal relations in the field of labour compensation for the employees of state budgetary and autonomous educational institutions in the Republic of Crimea.
- 1.2. The labour compensation system for the employees of state budgetary and autonomous educational institutions in the Republic of Crimea (“educational institutions”) shall include the amounts of the official salaries (wage rates) and compensatory and incentive payments and shall be established by a collective agreement, individual employment agreements and local regulations in accordance with the labour laws of the Russian Federation containing the rules of labour law as well as this Regulation.
- 1.3. The following terms used in this Regulation shall have the following meanings:
 - “official salary” means a fixed amount of pay due and payable to an employee for the performance of his or her labour (official) duties of a certain complexity, exclusive of any compensatory, incentive, social or other payments provided for by this Regulation;
 - “base unit” means a unit used to calculate the official salaries and salary rates for employees;
 - “base coefficient” means a relative value depending on the level of education;
 - “work specificity coefficient” means a relative value depending on the working conditions, type of institution and its structural divisions;
 - “qualification coefficient” means a relative value depending on the level of qualifications of an employee;
 - “management scale coefficient” means a relative value depending on the pay group determined based on certain volumetric indicators according to Table 6;
 - “management level coefficient” means a relative value depending on the position attributed to Management Levels 1 through 4;
 - “compensatory payments” means payments made to increase the wages payable to those employees engaged in hard works or working under harmful and/or dangerous, abnormal or other special working conditions or in areas with special climatic conditions, and other payments;
 - “incentive payments” means payments made to motivate employees to achieve high-quality results or for the work done; and

“social payments” means payments that involve costs to provide social benefits to employees in the form of a financial aid for their leaves to prevent diseases.

- 1.4. The wage of the employees of educational institutions consists of:
 - official salary rate;
 - compensatory payments;
 - incentive payments; and
 - social payments.
- 1.5. In order to prevent wages from being paid in amounts below the minimum wage in the Republic of Crimea, the head of an educational institution shall make additional monthly payments to those employees whose wages are less than a specified value, provided that said employees fully meet the applicable labour standards and work the monthly number of working hours.

The employer shall adjust the amounts of wages payable to low-paid employees to the minimum wage within the limits of the budget allocations made, budget liabilities of the Republic of Crimea and proceeds from other income-generating activities.
- 1.6. When forming an annual fund for compensatory and incentive payments, the funds for the payment of the official wages and salaries shall be annually provided in the following amounts:
 - up to 30% for educational institutions of all types; and
 - up to 10% for social payments.
- 1.7. Where and as provided for by the collective agreement, individual employment agreement or local regulation, in consultation with the Ministry of Education, Science and Youth of the Republic of Crimea, one-time bonuses for anniversaries and holidays may be paid to employees out of reasonable savings of the budgeted wage fund or out of proceeds from income-generating activities.
- 1.8. The base unit shall amount to RUB 6,200. The amount of the base unit shall be subject to indexation as and when determined by the Council of Ministers of the Republic of Crimea.
- 1.9. The wages and salaries due and payable to the employees shall be paid out of the payroll fund formed from the subsidies granted to and received by each educational institution in accordance with the prescribed procedure from the budget of the Republic of Crimea, or out of proceeds from other income-generating activities.

2. Salaries of Managers, Experts and Employees

- 2.1. The salary of the chief executive manager, deputy chief executive managers and managers of the structural divisions of an educational institution shall be calculated by summing up the monthly increment for the academic degree, the increment for the supply of books, other printed products and periodicals, the product of the base unit, the base coefficient, and the sum of the work specificity coefficient, qualifications coefficient, management scale coefficient and management level coefficient, which sum is then increased by one.
- 2.2. The salary of an expert of an educational institution shall be calculated by summing up the monthly increment for the academic degree, the increment for the supply of books, other printed products and periodicals, the product of the base unit, the base coefficient, and the sum of the work specificity coefficient and qualification coefficient, which sum is then increased by one.
- 2.3. The salary of an employee of an educational institution shall be calculated as the product of the base unit, the base coefficient and the works specificity coefficient, which product is then increased by one.
- 2.4. The monthly increment for the academic degree shall be established in the following amounts, provided that it corresponds to the profile of the institution or the position held:
 - 20% of the base unit for the academic degree of Doctor of Sciences and 10% of the base unit for the academic degree of Candidate of Sciences for the employees of higher vocational and supplementary vocational educational institutions; and
 - 10% of the base unit for the academic degree of Doctor of Sciences and 5% of the base unit for the academic degree of Candidate of Sciences for the employees of educational institutions other than higher vocational and supplementary vocational ones.

The monthly increment for the academic degree shall be established by order (instruction) of the head of each educational institution based on the documents proving said degree.

The monthly increment for the academic degree shall be accrued based on the actual hours worked with due regard for the applicable workload.

- 2.5. The increment for the supply of books, other printed matter and periodicals shall be provided for teachers (including managers whose activities are associated with the educational process) in order to facilitate their efforts to supply books, other printed matter and periodicals to their education institution.

The monthly increment for the supply of books, other printed matter and periodicals shall be established in the following amounts:

- RUB 150 in higher vocational and supplementary vocational educational institutions; and

- RUB 100 in other educational institutions.

The increment for the supply of books, other printed matter and periodicals shall be accrued on a monthly basis based on the actual hours worked with no regard for the applicable workload. This increment shall be included in the calculation of the average earning in accordance with the prescribed procedure.

- 2.6. The prescribed values of the base coefficient are shown in Table 1 below.

Table 1. Prescribed values of the base coefficient

Education level of the manager, experts or employee	Prescribed value of the base coefficient
Higher vocational education proved by the admittance a person successfully passing the final certification to the qualification (degree) of “expert”, “master or “bachelor”	1.50
Secondary vocational education under mid-level expert training programmes or incomplete higher education (with a diploma)	1.30
Secondary vocational education under skilled workers (employees) training programmes	1.20
Secondary general education	1.10
Primary general education	1.00

- 2.7. The prescribed values of the work specificity coefficient are shown in Table 2 below.

Table 2. Prescribed values of the work specificity coefficient

Type of educational institution, type of activity, and employee category	Prescribed value of the work specificity coefficient
1. Preschool educational institutions	
1.1. The work carried out by a teacher to manage methodological associations (the coefficient is applied to the work rate)	0.05
1.2. The work carried out by an educator to perform the functions of working with families of pupils	0.1
1.3. The work carried out by a teacher in groups of children with the use of national languages (Crimean Tatar or Ukrainian) (the coefficient is applied to the actual workload)	0.1
1.4. The work carried out by a teacher to manage a speech therapy centre (the coefficient is applied to the work rate)	
1.5. The work carried out by a teacher in groups of children with disabilities (the coefficient is applied by the actual workload)	
1.6. The work carried out by a teacher in compensatory groups (the coefficient is applied on the actual workload)	
1.7. The work carried out by an assistant or junior educator in compensatory groups type (the coefficient is applied by the actual workload)	

Type of educational institution, type of activity, and employee category	Prescribed value of the work specificity coefficient
2. General educational institutions	
2.1. Chief librarian and librarians for working with educational collections (the coefficient is applied to the work rate)	0.05
2.2. The work carried out by Level 1 and Level 2 managers whose activities are directly associated with educational activities, teachers of gymnasiums, lyceums, sanatorium schools, schools with in-depth study of certain subjects, and boarding schools	
2.3. The work carried out by a teacher in association with the following activities: <ul style="list-style-type: none"> • the checking of notebooks for teachers of primary classes, literature, Russian, mathematics, drawing, foreign and national languages (Crimean Tatar and Ukrainian) (the coefficient is applied to the actual workload); • the management of an educational or methodical office, workshop, class, laboratory, educational consulting office or experimental site (the coefficient is applied to the work rate); and • the management of methodological associations (the coefficient is applied to the work rate) 	
2.4. The work carried out by a teacher to perform the duties of a homeroom teacher (the coefficient is applied to the work rate)	
2.5. The work carried out by a teacher (the coefficient is applied to the actual workload): <ul style="list-style-type: none"> • in classes (groups) for children with disabilities; and • in classes (groups) with compensatory education 	
2.6. Teaching of national languages (Crimean Tatar and Ukrainian) (the coefficient is applied according to the actual workload)	0.1
2.7. The work carried out by of a teacher to manage a speech therapy centre (the coefficient is applied to the work rate)	
2.8. The work carried out by a preschool group teacher to perform the functions of working with families of pupils (the coefficient is applied to the work rate)	
2.9. The work carried out by an assistant or junior educator in compensatory preschool groups (the coefficient is applied by the actual workload)	
3. Supplementary educational institutions	
3.1. The work carried out by Level 1 and Level 2 managers whose activities are directly associated with educational activities and teachers of: <ul style="list-style-type: none"> • specialised children and youth Olympic reserve sports schools; and • high sports mastery schools 	0.05

Type of educational institution, type of activity, and employee category	Prescribed value of the work specificity coefficient
4. Vocational educational institutions	
4.1. Chief librarian and librarians for working with educational fund (the coefficient is applied to the work rate)	0.05
4.2. The work carried out by a teacher in association with the following activities: <ul style="list-style-type: none"> • the checking of notebooks for teachers of literature, Russian, mathematics, drawing, foreign and national languages (Crimean Tatar and Ukrainian) (the coefficient is applied to the actual workload); • the management of an educational or methodical office, workshop, class, laboratory, educational consulting office or experimental site (the coefficient is applied to the work rate); and • the management of methodological associations or cycle commissions (the coefficient is applied to the work rate) 	
4.3. The work carried out by a teacher to perform the duties of a homeroom teacher (the coefficient is applied to the work rate)	
4.4. Teaching of national languages (Crimean Tatar and Ukrainian) (the coefficient is applied to the actual workload)	
5. Higher vocational educational institutions	
5.1. Chief librarian and librarians for working with educational collections (the coefficient is applied to the work rate)	0.05
5.2. Subject matter experts for the management of subject matter, cycle and methodological commissions and classes	
5.3. Teaching of national languages (Crimean Tatar and Ukrainian) (the coefficient is applied to the actual workload)	0.1
5.4. The work carried out by scientists (researchers) engaged in arranging for and carrying out research and development works	
6. Supplementary vocational educational institutions	
6.1. Chief librarian and librarians for working with educational collections (the coefficient is applied to the work rate)	0.05
6.2. Subject matter experts for the management of subject matter, cycle and methodological commissions (the coefficient is applied to the work rate)	
6.3. Teaching of national languages (Crimean Tatar and Ukrainian) (the coefficient is applied to the work rate)	0.1

2.8. The qualification coefficient consists of:

- the qualification category coefficient;
- the academic title coefficient; and
- the state award coefficient for state awards (such as orders, medals, badges, honorary titles, sports titles and certificates of honour) of the Russian Federation, the USSR, Ukraine, and the RSFSR, for awards and honorary titles of the Republic of Crimea, or for departmental labour insignia of the Russian Federation, the USSR, Ukraine, and the RSFSR.

The qualification coefficient for the employees of educational institutions shall be calculated by summing up the qualification category coefficient, the academic title coefficient and the state award coefficient (for state awards such as orders, medals, badges, honorary titles, sports titles and certificates of honour) of the Russian Federation, the USSR, Ukraine, and the RSFSR, for awards and honorary titles of the Republic of Crimea, or for departmental labour insignia of the Russian Federation, the USSR, Ukraine, and the RSFSR.

2.8.1. The qualification category coefficient shall be assigned for:

- experts; and
- managers of educational institutions.

The prescribed values of the qualification category coefficient are shown in Table 3 below.

Table 3. Prescribed values of the qualification category coefficient

Ground for assigning the qualification category coefficient	Prescribed value of the qualification category coefficient	
	Educational institutions other than higher and supplementary vocational institutions	Higher and supplementary vocational educational institutions
Qualification category:		
• Higher	0.25	—
• First	0.15	—
• Second*	0.10	—
Research activity qualification category:		
• Chief Research Fellow	—	0.50
• Lead Research Fellow	—	0.40
• Senior Research Fellow	—	0.30
• Research Fellow	—	0.20
• Junior Research Fellow	—	0.10

Ground for assigning the qualification category coefficient	Prescribed value of the qualification category coefficient	
	Educational institutions other than higher and supplementary vocational institutions	Higher and supplementary vocational educational institutions
Educational activity qualification category:		
• Professor	–	0.25
• Associate Professor	–	0.20
• Senior Teacher	–	0.15
• Teacher	–	0.10
• Assistant	–	0.05

* For the period of three months following the official publication of this Regulation until the relevant teachers are confirmed to meet the requirements for their positions based on an assessment of their professional activities (according to Ministry of Education and Science of the Russian Federation Order No. 276 dated 07.04.2014).

2.8.2. The prescribed values of the academic title coefficient are shown in Table 4 below.

Table 4. Prescribed values of the academic title coefficient

Ground for assigning the academic title coefficient	Prescribed value of the academic title coefficient**	
	Educational institutions other than higher and supplementary vocational ones	Higher and supplementary vocational educational institutions
Academic title:		
• Professor	-	0.35
• Associate Professor	-	0.20

** The academic title coefficient is subject to compliance with the profile of the institution's activities or the position held.

2.8.3. The state award coefficient for state awards (such as orders, medals, badges, honorary titles, sports titles and certificates of honour) of the Russian Federation, the USSR, Ukraine, and the RSFSR, for awards and honorary titles of the Republic of Crimea, or for departmental labour insignia of the Russian Federation, the USSR, Ukraine, and the RSFSR shall be assigned to managers and experts of educational institutions.

The prescribed values of the state award coefficient for state awards (such as orders, medals, badges, honorary titles, sports titles and certificates of honour) of the Russian Federation, the USSR, Ukraine, and the RSFSR, for awards and honorary titles of the Republic of Crimea, or for departmental labour insignia

of the Russian Federation, the USSR, Ukraine, and the RSFSR are shown in Table 5 below.

Table 5. Prescribed values of the state award coefficient

Ground for assigning the state award coefficient	Prescribed value of the state award coefficient
State awards (such as orders, medals, badges, honorary titles, sports titles and certificates of honour) of the Russian Federation, the USSR, Ukraine, and the RSFSR, including:	
• orders, medals, and badges	0.40
• honorary and sports titles:	
• “People’s...”	0.40
• “Merited...”	0.30
• “Master of Sports...”	0.10
• “World-Class Master of Sports...”	0.25
• “Grandmaster...”	0.10
• “RF Presidential Prize Winner”	0.25
• certificates of honour from a Russian, Ukrainian, USSR or RSFSR executive authority performing management functions in the field of education	0.05
• honorary titles in the field of culture, including:	
• laureate of international competitions or exhibitions	0.25
• laureate of all-Russian competitions or exhibitions supported by the Russian Ministry of Culture	0.10
Departmental labour insignia of the Russian Federation, the USSR, Ukraine, and the RSFSR, including:	
• K.D. Ushinsky Medal	0.20
• “Honorary Worker...” badge or “Honorary Worker...” title	0.05
• other badges	0.05

If there are several grounds for assigning the state awards coefficient, it shall be assigned on one of those grounds in the maximum value.

- 2.9. The management scale coefficient shall be assigned based on the attribution of an institution to a labour compensation group by order of the Ministry of Education, Science and Youth of the Republic of Crimea.

The prescribed values of the management scale coefficient are shown in Table 6 below.

Table 6. Prescribed values of the management scale coefficient

Labour compensation group	Prescribed value of the management scale coefficient
Group 1	0.30
Group 2	0.20
Group 3	0.10
Group 4	0.05

- 2.10. The management level coefficient shall be assigned to an employee based on the attribution of his or her position to a management level.

The list of managerial positions as broken down by management level shall be approved by order of the Ministry of Education, Science and Youth of the Republic of Crimea.

The prescribed values of the management level coefficient are shown in Table 7 below.

Table 7. Prescribed values of the management level coefficient

Management level	Prescribed value of the management level coefficient
Level 1 (Chief Executive Manager)	1.00
Level 2 (Deputy Chief Executive Manager)	0.80
Level 3 (Manager of a Structural Division)	0.30

3. Salary Rates for Workers

- 3.1. The wages and salaries due and payable to the workers shall be paid in accordance with the Salary Rate Scale for the Workers of Educational Institutions, which is shown in Table 8 below.

Table 8. The Salary Rate Scale for the Workers of Educational Institutions

Labour compensation grade	1	2	3	4	5	6	7	8
Worker's salary, RUB	6,200	6,310	6,420	6,530	6,650	6,770	6,900	7,130

- 3.2. The professions of the workers of educational institutions shall be tariffed in accordance with the Unified Directory of Salary Rates and Qualifications of Works and Worker Professions.
- 3.3. Depending on the working conditions, compensatory payments may be made to workers as provided for in Section 5 of this Regulation.
- 3.4. In order to stimulate the high-quality results of labour, increase the efficiency of professional activities and reward for the work done, incentive payments may be made to workers as provided for in Section 6 of this Regulation.

4. Hourly Wages

- 4.1. Hourly wages shall be paid to teachers of educational institutions:
- for the teaching hours worked in the performance of the duties of a temporarily absent teacher for a period not exceeding two months; and

- for 300 teaching hours worked per year on a part-time basis for one or more other educational institutions in excess of the teaching workload.

The wage payable for one hour of such teaching work shall be calculated by dividing the official salary payable to a teacher for the prescribed number of teachings hours worked per week by the average monthly number of working hours.

- 4.2. The chief executive managers of educational institutions may attract, within the limits of the funds available to them, highly qualified experts to conduct training sessions with students, including for a short period, to deliver individual classes, courses, lectures, etc.

The wage payable for one hour of work shall be calculated by multiplying the base unit by the hourly wage coefficient.

The hourly wage coefficients for the employees engaged to conduct training sessions at educational institutions are shown in Table 9 below.

Table 9. Hourly wage coefficients for the employees engaged to conduct training sessions at educational institutions

No.	Indicator	Hourly wage coefficient		
		Professor or Doctor of Sciences	Associate Professor or Candidate of Sciences	No academic degree
1	Hourly wage coefficients for the employees engaged to conduct training sessions for students	0.12	0.10	0.05
2	Hourly wage coefficients for the employees engaged to conduct training sessions for graduate students and students of educational institutions offering advanced trainings for employees and experts	0.15	0.12	0.07

The wages payable to the members and reviewers of competition and contest juries shall be calculated by multiplying the base unit by the hourly wage coefficient for those persons conducting training sessions for students.

5. Compensatory Payments

- 5.1. The compensatory payments shall include:

- payments to employees engaged in hard works or working under harmful and/or dangerous and other special working conditions;
- payments for working in areas with special climatic conditions;

- payments for working under abnormal conditions (when performing works requiring various skills, combining professions/positions, working overtime, at night, on weekends or non-working public holidays or when otherwise working under other abnormal conditions);
 - increments payable for working with information constituting a state secret, classifying and declassifying such information or working with ciphers.
- 5.2. Payments to employees engaged in hard works or working under harmful and/or dangerous and other special working conditions shall be determined in accordance with Article 147 of the Labour Code of the Russian Federation based on the results of certification of workplaces.
- 5.3. Payments for working in areas with special climatic conditions shall be determined in accordance with Article 148 of the Labour Code of the Russian Federation.
- 5.4. Payments for working under abnormal conditions (when performing works requiring various skills, combining professions/positions, working overtime, at night, on weekends or non-working public holidays or when otherwise working under other abnormal conditions) shall be made in accordance with Articles 149 through 154 of the Labour Code of the Russian Federation.
- 5.5. The payments mentioned in Section 5.1 above shall be added to the official wage or salary and shall not constitute an increase in said official wage or salary for the purposes of calculation of other payments, increments or allowances.

6. Incentive Payments

- 6.1. The incentive payments shall include payments intended to encourage employees to achieve high-quality results of their work and payments for the work done, namely:
- payments for a high intensity and outstanding results of work;
 - payments for the high quality of the work done;
 - bonus payments based on the results of the work done;
 - long-service bonuses to teachers; and
 - other incentive payments.
- 6.2. Payments for a high intensity and outstanding results of work may be made for:
- a high efficiency of work;
 - taking an individual approach to students in classroom activities when implementing general education curricula;
 - participating in important works and socially significant events; and

- ensuring trouble-free and uninterrupted operations of all services of the educational institution.

The amount of a payment for a high intensity and outstanding results of work shall be calculated as a percentage of an employee's official wage or salary. The procedure for making such payment shall be prescribed by a regulation issued by the educational institution (with due regard for the recommendations contained in Letter No. AP-1073/02 dated 20 June 2013 from the Ministry of Education and Science of the Russian Federation). Such payment may be made during a period not exceeding one year.

- 6.3. The amount of a payment for the high quality of the work done shall be determined in accordance with the indicators and criteria for assessing the efficiency of each employee's performance as approved by local regulations of the educational institution.

Indicators showing the participation by each employee in efforts to create and use human, material, technical, financial, technological and information resources of the educational institution shall be used as criteria for assessing the quality of his or her performance.

Such indicators must be presented in a calculable form (in units, pieces, shares, percentage, etc.) so that they can be efficiently used as a tool for assessing performance.

Activities shall be subject to an indicator-based assessment based on statistical data as well as results of diagnostics, measurements, surveys, etc.

The assessment tools (criteria, types of work, indicators, and the weight of each indicator) shall be chosen depending on the analytical indicators applied to the activities of the educational institution.

The amount of a payment for the high quality of the work done shall be determined as a percentage of the official wage or salary of each employee. The procedure for making such payment shall be prescribed by a regulation issued by the educational institution. Such payment may be made during a period not exceeding one year.

- 6.4. Bonus payments based on the results of the work done may be made to reward employees for the overall results of their work during a fixed period.

The amount of a bonus payment based on the results of the work done by an employee shall be determined with due regard for:

- the successful and faithful performance by such employee of his or her job duties during such period (absence of complaints from his or her supervisor(s));
- the achievement or exceedance of the planned or specified performance indicators;

- the initiative, creativity and application of modern forms and methods of labour organisation in the work; and
- participation in any important works or socially significant events.

The bonus payments based on the results of work shall be made within the limits of the budget allocations made, the limits of budget liabilities of the Republic of Crimea and the proceeds from other income-generating activities. The amount of a bonus payment based on the results of work of each employee shall be determined as a percentage of the official wage or salary of such employee or as an absolute value.

6.5. The monthly long-service bonuses due and payable to teachers may be made as the following percentages of the base unit:

- 10% if the length of service exceeds 3 years;
- 20% if the length of service exceeds 10 years; and
- 30% if the length of service exceeds 20 years.

The main document for determining the length of an employee's teaching service shall be his or her employment record book.

The length of an employee's teaching service shall be proved by records in his or her employment record book and may be determined based on duly executed certificates signed by the chief executive manager(s) of his or her educational institution(s), sealed by the official seal(s) of such educational institution(s) and issued based on documents proving the length of his or her service in the profession (such as orders, service records, rate lists, staff registers, time record books, archival records, etc.). Each such certificate must state the name of the educational institution, the position and time worked therein, the date of issuance of the certificate, and the reason why such certificate was issued.

6.6. The other incentive payments shall include those payments not directly affecting the quality and efficiency of an employee's activities and intended to develop the staff of the educational institution. The procedure for making such payments shall be prescribed by a regulation issued by the educational institution.

7. Social Payments

7.1. The social payments shall include a financial aid for the prevention of diseases.

7.2. When employees of educational institutions go on an annual paid leave once in a calendar year, they are provided with a financial aid for the prevention of diseases.

Such financial aid for the prevention of diseases shall be paid within the limits of the budget appropriations made, the limits of budget liabilities of the Republic of Crimea and the proceeds from other income-generating activities available for the payment of wages and salaries.

A decision to pay such financial aid for the prevention of diseases to an employee shall be made by the chief executive manager of the relevant educational institution and formalised by his or her order.

In the event that an annual (regular) paid leave is split into parts in accordance with the prescribed procedure, the financial aid for disease prevention shall be paid when any such part of at least 14 calendar days is provided.

The financial aid for the prevention of diseases shall be paid to an employee upon a written request made by such employee at his or her main place of work and in his or her main position held.

The amount of any financial aid for the prevention of diseases shall be determined by a collective agreement, individual employment agreement or regulation issued by educational institution.

The payment of the financial aid for the prevention of diseases to an employee shall not depend on the results of such employee's performance assessment.

Those employees who have yet not worked a full calendar year shall be entitled to a financial aid for the prevention of diseases in an amount proportional to the time worked, including:

- the newly hired employees; and
- those employees dismissed at their own request, including in connection with their retirement.

No financial aid for the prevention of diseases shall be paid to:

- those employees hired on a part-time;
- those employees who have entered into a fixed-term employment contract (for a period of up to two months); and
- those employees dismissed for culpable acts.

8. Labour Compensation Terms for the Chief Executive Manager, Deputy Chief Executive Managers and Chief Accountant of an Educational Institution (Branch Thereof)

- 8.1. The wage of the chief executive manager, deputy chief executive managers and chief accountant of an educational institution (branch thereof) shall consist of his or her official salary as well as the compensatory, incentive and social payments provided for in this Regulation.
- 8.2. The official salary as well as the compensatory, incentive and social payments due and payable to the chief executive manager of an educational institution shall be determined by order of the Ministry of Education, Science and Youth of the Republic

of Crimea in accordance with this Regulation and specified in his or her employment contract.

8.3. The official salaries as well as the compensatory, incentive and social payments due and payable to the chief executive manager of a branch, the deputy chief executive managers and the chief accountant of an educational institution shall be determined by orders of the chief executive manager of such educational institution in accordance with this Regulation and specified in their employment contracts.

8.4. The wage due and payable to the chief executive manager of an educational institution shall be determined in accordance with the terms of this Regulation and may not exceed:

- four times the average wage of the employees of such educational institution if it is:
 - a preschool educational institution;
 - a general educational institution;
 - a supplementary educational institution for children; and
- six times the average wage of the employees of such educational institution if it is:
 - a secondary vocational educational institution;
 - a higher vocational educational institution; or
 - a supplementary vocational educational institution.

L. OPANASYUK,
Deputy Chair of the Council of Ministers of the Republic of Crimea and
Chief of Staff of the Council of Ministers of the Republic of Crimea

Annex 68

International Affairs, *Republic of Crimea: Education in Native Languages* (12 November 2019)

(excerpt, translation)

**Excerpt
Translation**

International Affairs, *Republic of Crimea: Education in Native Languages* (12 November 2019), available at: <https://interaffairs.ru/jauthor/material/2290>.

The Republic of Crimea: education in native languages

Aider Ablyatipov, Deputy Minister of Education, Science and Youth of the Republic of Crimea, Candidate of Pedagogical Sciences, Associate Professor

[...]

In 333 general education institutions, 410 teachers teach the Crimean-Tatar language, while 320 teachers teach the Ukrainian language in 181 general education institutions.

[...]

Annex 69

Supreme Court of the Russian Federation, Cassation Ruling No. 33-UD22-11-A2, 28 June 2022

(excerpt, translation)

Excerpt
Translation

Supreme Court of the Russian Federation, Cassation Ruling No. 33-UD22-11-A2, 28 June 2022, available at: https://vsrf.ru/stor_pdf.php?id=2134162.

**THE SUPREME COURT OF THE RUSSIAN
FEDERATION**

NO. 33-UD22-11-A2

CASSATION DECISION

Moscow, June 28, 2022

The Judicial Collegium for Criminal Cases of the Supreme Court of the Russian Federation composed of the presiding judge Abramov S.N., judges Romanova T.A., Peysikova E.V. with Mameichik M.A. as secretary of the judicial session with the participation of the prosecutor of the General Prosecutor's Office of the RF Fedchenko Y.A., the victim P and the convicted Orlov E.S. (via video-conference communication) and in defense of his interests - the lawyer Prokhorova N.A.

has considered at an open court hearing the criminal case on cassation appeals of convicted Orlov E.S. and victim P. against the sentence of the Leningrad Regional Court of May 21, 2021 and the appeal decision by the judicial panel for criminal cases of the Second Appeal Court of General Jurisdiction of August 16, 2021.

There are no scientifically based methods for psychophysiological examination using a polygraph, necessity of which Victim P. addresses in her complaint, and the results cannot be used as evidence in the case.

На основании изложенного, руководствуясь ст. 401.14 УПК РФ, Судебная коллегия
О П Р Е Д Е Л И Л А :

On the basis of the foregoing and in accordance with Article 401.14 of the RF CCrP, the Judicial Collegium HAS DECIDED:

The sentence of the Leningrad Regional Court of May 21, 2021 and the appeal decision by the judicial panel for criminal cases of the Second Court of Appeal of August 16, 2021 against Evgeny Sergeevich Orlov shall be upheld, the appeals of the convicted Orlov E.S. and the victim P shall be dismissed.

Presiding judge

Judges

Annex 70

Unian, Ukraine Cannot Do without Coal from the Occupied Territories - Head of the SBU
(26 January 2017)

(translation)

Translation

Unian, Ukraine cannot do without coal from the occupied territories - head of the SBU (26 January 2017), available at: <https://www.unian.ua/politics/1744361-ukrajina-ne-moje-obiytisya-bez-vugillya-z-okupovanih-teritoriy-glava-sbu.html>.

Ukraine cannot do without coal from the occupied territories - head of the SBU

UNIAN editorial office

He stated this to the journalists at a briefing, reports Espresso.TV.

“There are things that are extremely necessary for our economy. Coal is extremely necessary for our economy. The SBU does not regulate who will supply coal to the Kiev-controlled territory and in what quantities. But we cannot do without this coal, as far as I know from the officials of the Ministry of Ecology”, said Grytsak.

According to him, the process of shipping across the demarcation line, including coal, was controlled by the SBU from the very beginning of the war in Donbass, but then it initiated the creation of an interdepartmental group, which was supposed to reduce the risks of corruption when moving goods across the demarcation line.

Grytsak said that now this decision has already been canceled and the SFS has the role of controlling the process of moving goods across the demarcation line, and the role of the SBU is the control over the actions of the SFS officials.

As UNIAN reported, ATO veterans plan to block another railway route as part of the trade blockade of the occupied regions of Donbass.

It is to be recalled that on 25 January, ATO veterans began the third stage of the blockade of trade with the occupied territories of Donbass, blocking the road Lugansk - Popasna.

Annex 71

Zaxid.net, Deputy Prime Minister says how much coal Ukraine buys from the occupied territories (16 December 2016)

(translation)

Translation

Zaxid.net, Deputy Prime Minister Says How Much Coal Ukraine Buys from the Occupied Territories (16 December 2016), available at: https://zaxid.net/vitsepremyer_povodomiv_skilki_vugillya_kupuye_ukrayina_z_okupovanih_teritoriy_n1412782.

Deputy Prime Minister says how much coal Ukraine buys from the occupied territories

Yulia Polikovskaya



Up to 9 million tons of coal are supplied to Ukraine from the occupied territories of Donbass per year.

Ukraine buys up to 9 million tons of coal a year in the occupied territories of Donbass. This was announced by Deputy Prime Minister Vladimir Kistion on the air of the “24” TV channel.

"We receive coal from the occupied territories in the amount of up to 9 million tons per year", – he said.

According to Kistion, the suppliers of this coal are Ukrainian companies that are registered on the territory of Ukraine and pay taxes to the state budget.

"These are not just Akhmetov's companies," the Deputy Prime Minister said.

At the same time, he said that Ukraine no longer buys coal from Russia.

Annex 72

Cenzor.net, *Chernysh is Against Ban on Goods Transportation Through Contact Line* (26
December 2019)

(translation)

Translation

Censor.net, *Chernysh Is Against Ban on Goods Transportation through Contact Line* (26 December 2019), available at:

https://censor.net/ru/news/421058/chernysh_protiv_zapreta_na_provoz_tovarov_cherez_li_niyu_soprikosnoveniya_na_donbasse_neobhodimo_imet.

Chernysh Is Against the Ban on the Transportation of Goods through the Contact Line in Donbass: "It Is Necessary to Be Able to Move Coal, Otherwise We Will Have a Problem All Over the Country"

Censor.NET

Minister for the Temporarily Occupied Territories and Internally Displaced Persons, Vadim Chernysh, opposes a possible ban on the transportation of goods through the contact line in Donbass, because this could lead to power outages in the controlled territory of Ukraine.

"If you want the country to live through the autumn-winter period without blackouts throughout the whole territory of Ukraine, then it is necessary to have the possibility to move the coal, otherwise, we will have a problem across the country," the Minister said in the interview to "Interfax-Ukraine", commenting on the idea of a ban on the transportation of goods across the contact line, informs Censor.NET.

According to him, 9-9.2 million tons of coal are supplied from uncontrolled territories per year, because the thermal power plants were built to work with a certain type of coal - anthracite, which mainly uncontrolled territories have. At the same time, such coal is extracted at mines owned by Ukrainian companies and burned at Ukrainian enterprises.

The Minister does not believe that such a ban will contribute to the process of releasing the hostages.

Previously, Deputy Prime Minister for ATO and the Occupied Territories questions Vladimir Kistion declared that Ukraine buys up to 9 million tons of coal from the occupied territories per year.

Annex 73

*Ukrainian railway, Due to the blocking of train traffic in the Donbass, Ukraine did not receive almost 240 thousand tons of thermal coal, and the industry suffered UAH 53.5 million in losses
(15 February 2017)*

(translation)

Translation

Ukrainian railway, *Ukraine did not receive nearly 240,000 tons of thermal coal due to the blocking of trains in Donbass, and the industry suffered UAH 53.5 million in losses* (15 February 2017), available at:

https://web.archive.org/web/20220328103230/https://www.uz.gov.ua/press_center/up_to_date_topic/445344/.

15.02.2017

Ukraine did not receive nearly 240,000 tons of thermal coal due to the blocking of trains in Donbass, and the industry suffered UAH 53.5 million in losses

Due to the actions of unknown persons, the regional branch of “Donetsk Railway” suffered UAH 53.5 million in losses from the blocking of train traffic, and Ukrainian thermal power plants and TPPs did not receive almost 240,000 tons of thermal coal. In total, in Donbass, unknown persons blocked 3 sections, seized 3 locomotives, 57 empty cars and 47 cars with coal.

The regional branch of “Donetsk Railway” once again appealed to the Main Directorate of the National Police in the Donetsk and Lugansk regions, to the Main Directorate of the Security Service of Ukraine in the Donetsk and Lugansk regions with a request to urgently take measures to unlock the three sections.

It is to be recalled that since 10 February 2017, the Fenolna - Krivoy Torets section has been blocked, traffic has been completely stopped. Outsiders seized the electric locomotive, established control over it and put it into operation. The blockers removed the locomotive crew to the non-working cabin of the locomotive and prevented railway workers from performing their duties.

On 2 February, the Kurdiunivka - Bakhmut-2 section was blocked. The very first section, Shypylove-Svitlanove, was blocked on 25 January 2017.

Annex 74

Slovo i dilo, *Coal case of Poroshenko-Medvedchuk: details of procurement announced by SBI*

(17 January 2022)

(translation)

Translation

Slovo I Dilo, Coal case of Poroshenko-Medvedchuk: the SBI announced the details of the purchases (17 January 2022), available at:

<https://www.slovoidilo.ua/2022/01/17/novyna/polityka/vuhilna-sprava-poroshenka-medvedchuka-dbr-ozvuchyly-vytraty-derzhbyudzhetu>.

Coal case of Poroshenko-Medvedchuk: the SBI announced the details of the purchases

The fifth president, Petr Poroshenko, along with Viktor Medvedchuk, Sergey Kuziara, and Vladimir Demchishin, in 2015, purchased coal with budget money from the “L/DPR” enterprises with a previous conspiracy.

The SBI representative, Tatiana Sapien, talked about this on Monday, 17 January, at a briefing in Kiev.

According to her, in general, during 2015, Ukraine transferred at least UAH 205.391 million for coal deliveries from the occupied territories of the so-called “LPR” and “DPR”, in addition to cash payments. According to the signed agreements, more than UAH 3.168 billion was to be paid from the budget.

According to the investigation, actions initiated by Poroshenko in 2014 were the main reason for the unilateral refusal of Steel Mont trading ltd to supply coal from South Africa.

Then, according to Sapien, Centerenergo found itself in artificially created conditions, under which it had the opportunity to import coal only from the Russian Federation. At the same time, the Russian Federation blocked coal supplies, leaving the possibility of coal supplies exclusively from the Russian-occupied territories of Ukraine.

From November 2014 to January 2015, Viktor Medvedchuk began work on the organization of coal deliveries by enterprises whose property was under the control of the so-called “LPR” and “DPR”. In turn, Viktor Medvedchuk and Petro Poroshenko exerted administrative pressure on employees of the Ministry of Energy and the Coal Industry, the National Bank of Ukraine and Central Energy to pay money directly to the leaders of the so-called “LPR” and “DPR” and conclude direct contracts for the purchase and sale of coal with terrorists.

As Sapien emphasized, as a result of these actions, the energy sector of Ukraine became dependent on the Russian Federation and the enterprises in the Russian-occupied territories of Ukraine.

Details of the functioning of the criminal scheme of coal supply from the Russian-occupied territories of Ukraine and assistance to “L/DPR” terrorist organizations State Bureau of Investigation

It is to be recalled that, on 20 December 2021, Petro Poroshenko was informed of suspicion of treason and facilitating the activities of terrorist organizations.

The former president is suspected of terminating contracts for the supply of coal from South Africa and organizing the supply of coal from the Russian-occupied territories of Ukraine.

On the 6th of January the court seized all of Poroshenko's property.

Today, on 17 January, Poroshenko returned from Poland to Ukraine.

The People's Deputy said the day before that he was not afraid of a possible arrest.

Annex 75

Hromadske, "*Coal case*": *Poroshenko was appointed a personal obligation* (19 January 2022)

(translation)

Hromadske, *Coal case*”: Poroshenko was assigned a personal recognizance (19 January 2022), available at: <https://hromadske.ua/posts/vugilna-sprava-poroshenka-vidpustili-pid-osobiste-zobovyazannya>.

hromadske

“Coal case”: Poroshenko was assigned a personal recognizance

[Iryna Sitnikova](#)

[Viktoriia Roschyna](#) 19 January 2022 14:18



The fifth president of Ukraine, Petr Poroshenko, in the courtroom, 17 January 2022
Viktoriia Roschyna / hromadske

The Pechersk District Court of Kiev chose a preventive measure against the fifth president of Ukraine, Petr Poroshenko, in the case of the purchase of coal from the occupied territories in the form of a personal recognizance. Poroshenko's lawyers plan to appeal this decision.

This is [stated](#) in the broadcast from the courtroom.

Prosecutors [asked](#) to take Petro Poroshenko into custody for two months with the possibility of a bail of UAH 1 billion. Instead, the court ordered a personal recognizance until 19 March 2022. After the end of this term the preventive

measure can be changed.

Personal recognizance is the mildest preventive measure. According to it, the suspect must fulfill the duties assigned to him by the court:

- not to leave Kiev and the Kiev region without the permission of the investigator, prosecutor or the court;
- to report a change of job or place of residence;
- to deposit a passport for travel abroad.

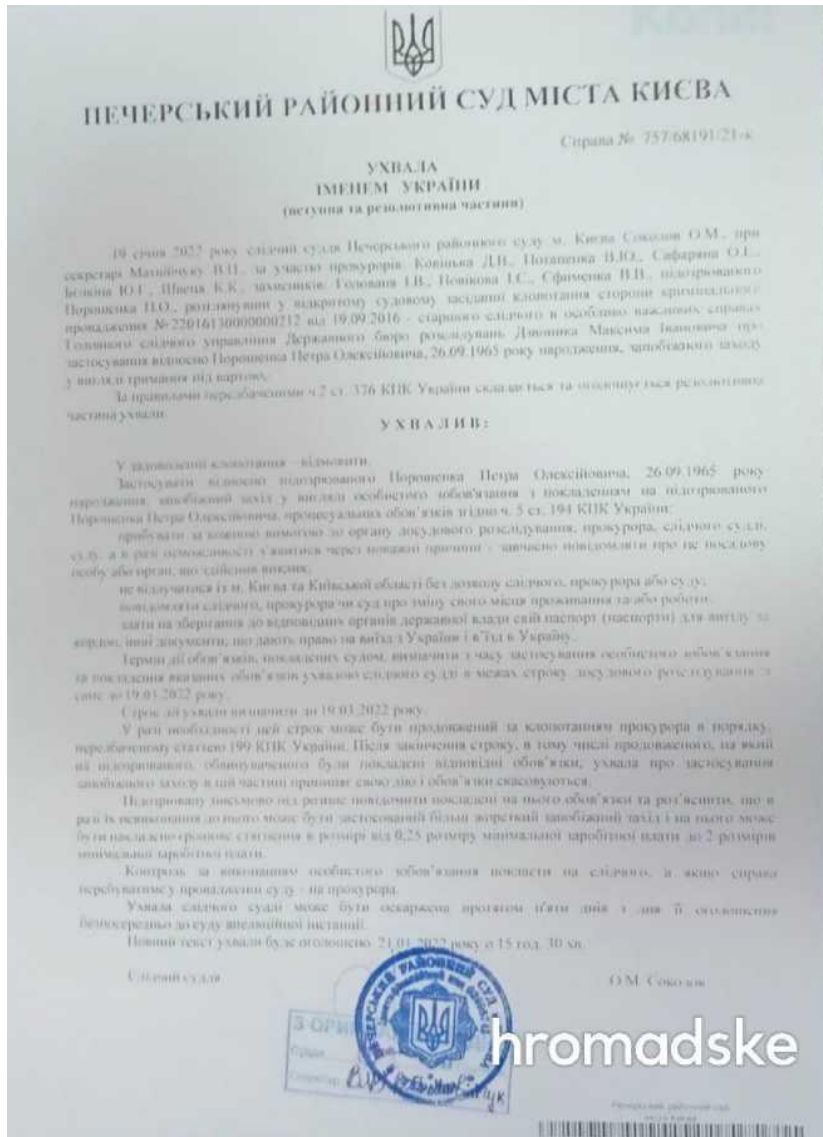

The text of the court decision Viktoriia Roschyna / hromadske

The suspect is informed about these obligations and it is explained that in case of non-fulfillment of them, a stricter preventive measure and a fine can be applied – from 0.25 to 2 times the subsistence minimum for able-bodied persons (from UAH 620 to UAH 4,962).

Lawyer Iliia Novikov, who represents the interests of Poroshenko, [stated](#) that the court's decision will be appealed. Poroshenko himself said that the court's decision will hinder his political work. He said he was invited for at least three foreign events.

Updated. The State Bureau of Investigation [stated](#) that a personal recognizance “*will not ensure the proper behavior of the suspect Petro Poroshenko*”, and therefore the prosecution can file an appeal.



The fifth president of Ukraine Petr Poroshenko in the courtroom, 19 January 2022 Viktoriia Roschyina / hromadske

After the announcement of the court's decision, the Ukrainian national anthem was sung in the hall, and Poroshenko made a speech in which he declared that he “*does not celebrate the victory*”.

Poroshenko also spoke before a crowd of several thousand gathered in support of the politician, after which his supporters went to a rally near the President's Office.

What is Poroshenko accused of?

On 20 December 2021 Petro Poroshenko was served with charges under three articles of the Criminal Code: regarding the financing of terrorism, treason and facilitating the activities of a terrorist organization. He faces up to 15 years in prison with possible confiscation of property. It is about a scheme for the supply of coal from the temporarily occupied territories for UAH 1.5 billion and assistance to terrorist organizations “LPR” and “DPR”.

Poroshenko is suspected of facilitating the activities of the “L/DPR”, and also in the purchase of coal in the occupied territories with state funds, based on a prior conspiracy with a group of people (in particular, representatives of the Russian top management). According to the investigation, by their actions, the perpetrators made Ukraine energy dependent on the Russian Federation and militants in Donbass.

In this case, besides Poroshenko, people's deputy Viktor Medvedchuk, former Minister of Energy and Coal Industry Vladimir Demchishin and businessman in the coal sector Sergey Kuziara are already involved.

Poroshenko's defense rejects the accusations. The ex-president's lawyers and he himself consider the case to be politically motivated.

Annex 76

NRC, Aid workers are staying in Afghanistan - as they do in crises globally. We must protect them (30 August 2021)

Aid workers are staying in Afghanistan - as they do in crises globally. We must protect them

Published 30. Aug 2021

As the world watches the unfolding crisis in Afghanistan, aid workers are staying to help while bracing for troubling times ahead. More must be done to protect humanitarians on the frontlines across the globe.

By United Nations Under-Secretary-General for Humanitarian Affairs and Emergency Relief Coordinator, Martin Griffiths, and the Secretary General of the Norwegian Refugee Council, Jan Egeland.

This opinion piece was originally published by [The Telegraph](#).

In June, two missiles hit one of the largest hospitals in northern Syria, killing 19 civilians, including three children and four humanitarian workers. An additional 11 hospital staff were injured.

Rockets hit the emergency room and delivery ward, reducing them to rubble. Al-Shifa'a hospital is now inoperable, and thousands of Syrians have been cut off from life-saving medical assistance.

Later that same month, three aid workers, clearly identified as working for an international aid organisation, were killed in Ethiopia's Tigray region.

Tragically, attacks like these have become commonplace. Every week, humanitarian workers across the world are killed, injured, sexually assaulted, kidnapped or detained as they work to help the world's most vulnerable people.

Humanitarian needs today are at a record high. Some [235 million](#) people need aid across 56 countries. This is due to the crippling combined effects of prolonged conflict, the climate crisis and COVID-19.

But reported attacks on aid workers have increased almost tenfold over the past 20 years according to Humanitarian Outcomes.

Last year, 475 aid workers were attacked and 108 of them killed in 41 countries – the vast majority of them national aid workers working on the front lines of conflicts.

Humanitarian groups are often forced to temporarily suspend activities or relocate staff, depriving communities of life-saving aid deliveries and protection.

Robust international laws of war exist to protect relief operations and aid workers, and facilitate

aid reaching the people who need it to survive. But too often fighting parties – both states and non-state armed groups – brazenly flout them. And when they do, they face few consequences.

As humanitarian needs soar, we need urgent action to get aid workers and supplies out of the line of fire, and ensure relief gets to where it's needed.

First, states and non-state armed groups participating in armed conflict must live up to their fundamental obligations under international humanitarian law.

Experience shows that incorporating the laws of war in training and the rules of engagement for armies and armed groups works. As does adopting strong military policy and practice to ensure civilians and humanitarian access are protected.

States have many means of influence to get conflict parties to respect international humanitarian and human rights laws, ranging from political dialogue to withholding arms transfers where there is a clear risk that the arms will be used to commit serious violations of those laws. They need to consistently apply them.

Second, allegations of serious violations of international humanitarian law must be systematically and independently investigated, and perpetrators held to account. War crimes that go unpunished embolden perpetrators to commit further violations.

Third, governments must recognize the need for humanitarian organizations to neutrally engage with all parties, including non-state armed groups, to safely help people in need. This means that humanitarian organizations must be able to speak to whoever controls territories where populations are in need, so families living in areas under their control can receive humanitarian assistance.

A 2016 [study](#) commissioned by the aid group Geneva Call found that non-state armed groups expressed greater acceptance of international humanitarian law when there had been active in long-term engagement with humanitarians. These armed groups were more likely to deny access and even attack aid workers when humanitarian organizations were perceived to be supporting a political agenda.

One of us – Martin Griffiths – will soon appoint a special adviser on the preservation of humanitarian space and access. This is an opportunity to speed up progress on these critical areas. It will also need governments to take bold, practical steps to ensure respect for international law and facilitate humanitarian access.

And fourth, counter-terrorism measures must not impede humanitarian action, and should include clear exemptions to preserve the ability of humanitarian organizations to help people in need, wherever they are.

Counter-terrorism measures have often hindered humanitarian work in areas where armed groups are present, and at times have even criminalized legitimate aid activities, depriving civilians of life-saving aid precisely when international law entitles them to it.

Aid workers are staying in Afghanistan - as they do in crises globally... <https://www.nrc.no/opinions-all/aid-workers-are-staying-in-afghanista...>

National legislation in several countries, including recently in Chad and Switzerland, has excluded humanitarian activities from the application of counter-terrorism measures under criminal law. This is a step forward.

Today, World Humanitarian Day, is a moment to commemorate aid workers who have fallen. Taking meaningful and immediate action to protect each and every aid worker operating today is the best way we can honour their legacy.

Annex 77

AIF.RU, Ukrainian Barbarians. Ukrainian Nationalists Demolish Lenin Monument in Kharkov (29 September 2014)

(translation)

Translation

AIF.RU, *Ukrainian Barbarians. Ukrainian nationalists demolish Lenin monument in Kharkov* (29 September 2014), available at: <https://aif.ru/euromaidan/prediction/1348374>.

29 September 2014 12:05 Andrey Sidorchik

Ukrainian Barbarians. Nationalists Demolish Lenin Monument in Kharkov

Good old fashioned vandalism

Despite **Petr Poroshenko's** pompous statements about 60 reforms which will open the door to the European Union for Ukraine, creativity is clearly not the strong point of the Euromaidan adherents.

The mass murders, robbery, looting and racketeering, on the other hand, are what the "Ukrainian patriots" have excelled at in recent months.

And, of course, good old-fashioned vandalism, without which the "heroes of Ukraine" cannot live a day.

On 28 September, vandals attacked a monument to Lenin on Kharkov's main square. The monument, a 20-metre bronze figure cast by sculptors Oleynik and Vronsky, was unveiled in November 1963.

The largest monument to the leader of the world proletariat was first attacked by Euromaidan supporters in February 2014, but opponents of the demolition managed to repel the vandals then.

However, a lot has changed in Kharkov since February. Opponents of the new Kiev authorities were jailed by the hundreds and there were several "mop-ups" in the city, carried out by nationalists with the full connivance of the authorities.

The latest action to intimidate dissidents took place on 27 September. An attempt by Kharkov Communists to hold a "Peace March" in the city was brutally dispersed by representatives of the security services. Ukrainian Interior Ministry officers detained **Alla Aleksandrovskaya, first secretary of the Kharkov regional committee of the Communist Party of Ukraine**, and several dozens of protesters.

World experience teaches us that where communists are suppressed by the authorities, the extreme right excels. In Kharkov this rule was proved most clearly.

Nazi with an angle grinder

On 28 September, a rally called "Kharkov is Ukraine" was held in the city, which, according to police estimates, attracted around 3,000 participants. The core of the rally were Ukrainian Nazis, who believed that this was a good opportunity to complete what they failed to do in February 2014.

The attack on the monument started around 7pm. It was not difficult to identify the political affiliation of the attackers - they were not hiding Nazi symbols or flags of the Nazi Azov and UPA (Ukrainian Insurgent Army) battalions.

Beforehand, the abbreviation IN (a popular sign among the Ukrainian far-right that stands for "Idea of a Nation") was carved into the pedestal, after which participants turned to the figure of the leader himself.

It was decided to collapse the monument by sawing its leg off with a angle grinder. Needless to say that no safety precautions were taken in the process.

Since what was happening was clearly outside the law, the police officers, while not intervening in the process, nevertheless tried to label the actions of the right-wing radicals as illegal.

"Idol" and the minister

The Kharkov police said they had opened a criminal case over "the destruction of or damage to cultural heritage objects and property".

It followed from the statement made by the police that they attempted to explain to the protesters the illegality of their actions, but the protesters ignored the policemen's words.

But while the Kharkov police were claiming that it was illegal to demolish the monument, **Ukrainian Interior Minister Arsen Avakov** actually supported them in a post on his favourite Facebook network: "Lenin? Let it fall... As long as people don't get hurt. As long as this bloody communist idol does not add new names to his victims' list when walking away. As long as the scoundrels and rascals don't take advantage of Kharkov residents' storm of feelingst to incite another clash... I gave the command to the police to ensure the safety of people ONLY, not the idol...".

Unfortunately, the monument to Lenin could not answer Avakov. And there was something that could be said in reply to his words. For example, one could wonder whether an Armenian boy born in Azerbaijan could have made such an astounding career in Ukraine had it not been for Vladimir Lenin and his "proletarian internationalism". Not to mention that Ukraine's very existence within its current borders would not have been possible without the "bloody communist idols".

"Ah, Arsen, Arsen... You ungrateful bastard," the monument to Lenin in Kharkov seemed to say reproachfully to the head of the Ukrainian Interior Ministry before it fell.

Tail-wags-the-dog

It must be said that the destruction of the monument in Kharkov showed once again that the authorities in Ukraine are unable to resist actions of the Nazis in any way.

The head of the Kharkov regional administration, Igor Baluta, after learning about what was happening on the square, signed an order to... dismantle the Lenin monument.

The monument was "retroactively" ordered to be removed from Ukraine's register of monuments to give it the appearance of legality.

As modern Ukrainian officials should, Mr. Baluta delighted journalists with a glowing statement, saying that the demolition of the monument was carried out by... professionals.

"I think it was handled by professionals, but not at the level it should have been: I was worried about people, about possible casualties, but everything, thank God, is fine. Thank God there were no casualties, no injuries" Baluta said.

Apparently, as the head of the Kharkov region sees it, demolishing a monument by sawing it off with an angle grinder is professionalism. In all appearances, a difficult winter awaits not only people in Kiev and Mayor Klitschko, but also people in Kharkov under the reign of Mr Baluta.

As for the "professionalism" of those who demolished the monument, the following fact is telling: one of the nationalists had his eye knocked out with a broken rope in the process of demolishing the monument.

The Kharkov Nazis will not be held liable for anything other than physical injuries, of which the restless Arsen Avakov hastened to notify people on Facebook: "Given the issuance of the governor's directive to demolish the monument, I have given the command to end the criminal case for damage to the monument.

SS Leibstandarte Square

Of course, the Kharkov police were forced to comply with the decision of the governor and the head of the Interior Ministry.

In connection with Directive No. 517 of **the governor of Kharkov region Igor Baluta** "On Resolving the Situation in the Region Regarding Monuments of the Age of Totalitarianism" dated 28 September 2014, the investigator decided to terminate criminal proceedings under Article 298(2) ("Demolition or Destruction of or Damage to Cultural Heritage Objects") of the Criminal Code of Ukraine," Ukrainian Interior Ministry's public relations department in Kharkov Region stated.

To rid itself completely of the legacy of totalitarianism, Kharkov now needs just to rename the central square where the demolished Lenin monument stood.

In Soviet times it was called Dzerzhinsky Square, after the collapse of the USSR it was called Independence Square, and now it is called Freedom Square. During the Nazi occupation, it was called SS Leibstandarte Square. Isn't that name that may be restored? In today's realities, there is no more appropriate name.

Annex 78

Ukrainian Pravda, *Journalist Babchenko is Alive, the Murder is Staged* (30 May 2018)

(translation)

Translation

Ukrainian Pravda, *Journalist Babchenko is alive, the murder is staged* (30 May 2018), available at: <https://www.pravda.com.ua/rus/news/2018/05/30/7181836/>.

UKRAINSKAYA PRAVDA**JOURNALIST BABCHENKO ALIVE, MURDER STAGED**

WEDNESDAY, 30 MAY 2018, 17:21

Russian journalist Arkady Babchenko is alive, it was an SBU special operation.

This was reported by SBU chief Vasiliy Grytsak at a briefing on 30 May.

He said that the Security Service had received information about an attempt on Arkady Babchenko's life in advance.

"I can now report the details of a special operation by the Security Service of Ukraine, thanks to which we managed not only to foil the cynical provocation, but also to document the preparation of this impudent crime by the Russian special services," Grytsak said.

"I could offer condolences to Arkady Babchenko's family, but I will not do so. On the contrary, today I will congratulate Arkady on his third birthday and invite him into the hall," the SBU chief said after which Babchenko entered the hall.

The SBU claims that the Russian special services recruited Ukrainian citizen G. He, in turn, instructed his acquaintance, who had taken part in the antiterrorist operation in eastern Ukraine, to commit the crime.

At the same time, the former ATO soldier cooperated with special services. After allegedly "executing" the order, citizen G., who had been informed of this, was detained.

Valentina Romanenko, UP

Annex 79

Polit.ru, "*Kharkiv Partisans*" *Disclaim Responsibility for Terrorist Attack in Kharkiv*
(23 February 2015)

(translation)

Translation

Polit.ru, “*Kharkov Partisans*” *Disclaim Responsibility for Terrorist Attack in Kharkov* (23 February 2015), available at: https://polit.ru/news/2015/02/23/no_responsibility/

POLIT.RU

“Kharkov Partisans” Disclaim Responsibility for Terrorist Attack in Kharkov



Explosion at the memory rally in Kharkov

“Kharkov Partisans” said they were not involved in the terrorist attack in Kharkov on the 22nd of February, Filipp Ekoziants, a representative of the pro-Russian organisation, told in an interview with *Govorit Moskva* Radio.

“Kharkov Partisans” were not involved in any acts that can kill or endanger any civilians, including demonstrators supporting the ATO. The partisans understand there is a powerful information machine now operating in Ukraine, so they do not treat those people as enemies”, he said.

Mr. Ekoziants is sure the explosion was arranged for by order of Ukrainian Interior Minister Arsen Avakov so that Kiev could begin an anti-terrorist operation in the Kharkov Region.

“These are their methods of blowing up and then accusing those against whom they need to fight to mobilise all those deceived people against guerrillas or militias. They need guerrillas to

be bad, but they are not bad as they attack [military] vehicles and fuels but not people”, he said.

“Kharkov Partisans” found it difficult to describe who are the alleged organisers of the terrorist attack detained by the security forces.

Notably, the Ukrainian Interior Ministry earlier confirmed that “Kharkov Partisans” were involved in the terrorist attacks in Kharkov on the 22nd of February. The Ministry explained its opinion by the conclusions drawn by experts after studying the remains of an explosive device. In addition, the Security Service of Ukraine (SSU) said the alleged criminals had been armed by Russia.

Mass Media Registration Certificate El. No. 77-8425 of 1 December 2003,
issued by the Russian Federation Ministry for Press, Television and
Radio Broadcasting, and Mass Media.

Online since 21 February 1998.

You must refer to *polit.ru* if you use any of the materials placed on our website.

You must also refer to *polit.ru* if you reprint any of those materials on the Internet.

All rights reserved and protected by law.

© *Polit.ru*, 1998-2023.

Annex 80

Korrespondent.net, *SSU Has Tortured Marina Kovtun Accused of Blowing up Stena Rock Pub
for Three Years* (22 November 2017)

(translation)

Translation

Korrespondent.net, *SSU Has Tortured Marina Kovtun Accused of Blowing up Stena Rock Pub for Three Years* (22 November 2017), available at: <https://blogs.korrespondent.net/blog/events/3909377/>

SSU Has Tortured Marina Kovtun Accused of Blowing up Stena Rock Pub for Three Years

Korrespondent.net

The explosion in the Stena Rock Pub occurred on the 9th of November, injuring 13 people.

Marina Kovtun, who is accused of arranging for the explosion of the Stena Rock Pub in Kharkov on the 9th of November 2014, has been in prison for three years. She could be exchanged as, unfortunately, neither an acquittal nor a fair trial is possible for her, but the prosecution refuses to include Marina in the exchange lists, calling her a terrorist working for Russian special services. She is charged with actions aimed at changing the state border, acts of sabotage, a terrorist act, the leadership of a terrorist group as well as the acquisition and storage of weapons and ammunition (which are criminalised under Articles 110(1), 28(2), 113, 27(5), Article 258(2), 258-3(1), 28(2), 32(1) and 263(1) of the Ukrainian Criminal Code).

How Did It All Occur? Rallies and Explosion in Stena Rock Pub

According to open sources, Marina was a member of “Kharkov Resistance”, a group that arranged for various explosions, terrorist attacks and so on in order to “destabilise the situation in the largest city in Eastern Ukraine”. However, I must make a reservation that all these sources are entirely Ukrainian – in other words, “patriotic”. Why would a woman in her forties, who had a family and a job, go to terrorists? Of course, older people did attend the numerous rallies in Kharkov in 2014, but in no way were they committed to a forceful solution. In the First Capital of Ukraine, few people even thought about such a turn of events as Kharkov residents had neither weapons nor explosives. Even at the peak of the “Russian Spring”, when some “hotheads” wanted to “borrow” weapons from policemen and SSU officers, it turned out that all weapon stores were long empty and the ammunition, pistols and machine guns had been taken to an unknown destination. Therefore, all the anti-Maidan protesters had were five to ten nonlethal and gas pistols per thousands of protesters. This picture, in general, is quite different from Kyiv’s “revolution of dignity”, where machine guns were delivered in shopping bags.

Yes, while many Kharkov residents admit Maryna was committed to federalisation, she was not an active partaker. However, a suspicion is often enough in Ukraine to put an innocent person behind bars for years.

Let us go back to the “terrorist attack”. The explosion in the Stena Rock Pub occurred on the 9th of November, injuring 13 people. The place was famous for its audience consisting of nationalists, ultras and ATO participants. Just a couple of hours after the explosion, the Stena’s director said a terrorist attack had taken place in his institution. According to him, it occurred due to the “assistance to refugees from Donbas”.

“We collect aid for refugees, military and orphans. It does not matter why has which views on whom we are helping – the fact remains. I believe it was a terrorist attack. Yes, my business had no competitors”, the Stena’s owner told local journalists.

However, all Kharkov residents know the main aid this Pub collected was really intended to wage the war against the inhabitants of Donbas – mainly the Nazis from Azov, whose leader Andriy Biletsky, who is notorious in Kharkov, is now a member of the Ukrainian Verkhovna Rada. It has not yet been possible to find out whom of the orphans did the director help.

By the way, they say Stena was expected to accommodate another gathering of nationalists coming from the ATO area on the day of the explosion. But it is also impossible to confirm this fact for certain.

Just a couple of days later, Alexander Pivovar, the then head of the SSU SBU in the Kharkov Region, found a “Russian trace” in the terrorist attack case. According to him, mines similar to those used to blow up the Pub were used in the Soviet era and are now in service with Russia.

A little later it turned out the bomb was homemade. However, for some reason, all local media forgot about Mr. Pivovar’s words and began claiming the explosive had been directly imported from a neighbouring country. And what about the mines, I want to ask?

After a while, reports appeared that a RGD-5 grenade exploded in the Pub, which could be brought in by ATO participants.

But the indictment states... SPM mines developed in the USSR and having a guaranteed shelf life of 10 years.

Arrest and Confession

On 17 November 2014, the SSU reported the capture of 12 people, including two alleged leaders of the group.

“AK-74 assault rifles and ammunition, RGD-5 and VOG-25 grenades, detonators, stretcher kits as well as 7 anti-personnel mines marked by Russian manufacturers, which are prohibited for use by the Ottawa Convention of 1997, were seized from them”, the SSU’s press service said in its statement.

Most of the “terrorists” underwent “*good training in the Russian Federation*”. A video report was also seized from them, apparently intended specially for the GRU, confirming the explosions.

Literally the day after the arrest, a video was circulated on the Internet, showing a certain woman confessing to having arranged for the terrorist attacks.

“During one of the visits, I was recruited by representatives of the Russian GRU. I was given the call sign “Zeta” (Z) and was tasked with selecting members of the group from among the Kharkov anti-Maidan activists to commit sabotage in the Kharkov Region”, she says.

As it turned out later, she was recruited in July, sent to study mine blasting in August and introduced into the organisation called “Kharkov Partisans” in October, and the first explosion she is accused of took place in the mine of the Malyshev Plant on the 8th of November. According to the prosecution, Russian special services officers managed to train a 48-year-old woman, who previously worked as a seamstress, to deal with explosives in just a month or two.

In principle, everything is logical, given the complete lack of logic in the actions taken by the SSU.

However, Marina Kovtun’s sister Larisa told a slightly different story. According to her, law enforcement officers arrested five members of her family, and some things and money disappeared from their house during the searches.

“Marina went to her old parents as she often did. She was driving a car with her nephew to the train station. She was stopped and arrested. Then they went on and arrested two more nephews. Then they arrested her son and then mine. By the way, the car was seized by the SSU”, Larisa said.

According to her, when she saw the video of Marina confessing to having worked for “Russian special services”, she realised those words had been knocked out of her under torture.

“She has absolutely nothing to do with it (the explosion in the Stena Rock Pub – editor’s note). She didn’t do anything like that. I saw her confession on the Internet, and I could hear from her voice that it hurt her to talk. Just imagine how she was beaten if, when I saw her four weeks later in prison through two windowpanes and two bars, one side of her face was still just blue. I just cannot imagine what happened to her then”, Marina’s sister said.

“When I visited her in prison, she told me, ‘There was hell (in the SSU when I was arrested – Editor’s note), and here, Lara, I can live’”, Larisa added.

Investigation and Judicial Proceedings

The trial in Marina’s case has been lasting 2.5 years, and the investigation ended in mid-June 2015. In the mass exchange between the People’s Republics and Ukraine, which took place in the winter of 2014-2015, the other “suspects” involved in the case were exchanged for captured ATO participants.

“Up to fifty people were exchanged in several stages, including those detained for the explosion in the Stena. Just to make a reservation: the man who brought the explosive device into the pub was absent from the group. He fled immediately after the terrorist attack”, Kharkov Regional Prosecutor Yuri Danilchenko said.

Thus, only Marina remained in the dock. The prosecution specifically requested that she be excluded from the exchange list because “the blood of Kharkov residents is on her hands”.

“As regards the Stena, except for Marina Kovtun, who was the arranger, that was my position and that of the regional prosecutor, she was on the lists, but was crossed out as she has real blood on her hands”, Mr. Pivovar said.

By the way, according to the investigation, Dmitry Loginov, the escaped man who allegedly brought the mine prepared in advance by Marina into the pub, fled the day after the explosion. However, the terrorist attack in Zhuravlevka near the Britaniya Restaurant, which was allegedly carried out by Loginov and which Marina Kovtun is also charged with, occurred on the 11th of November. Inconsistency, Your Honour.

In general, the case files have been classified. Marina's lawyers cannot comment on this lawlessness in fear of being accused of disclosing the investigation secrets.

The only thing that can be noted is that there are quite a few violations in the proceedings, including the delivery of the indictment to Marina. It was reportedly given to her via a feeding window in her pre-trial detention cell without the presence of her lawyer and prosecutor, who were simply required to be present there by the procedural rules.

At the moment, Marina has retracted all her testimonies as knocked out under torture and does not admit her guilt.

Meanwhile, Larisa Chubarova, another political captive recently sentenced to 11 years in prison, noted in her personal letter that Marina was in a very bad condition and asked that her fate be somehow alleviated.

“Marina Kovtun’s fate worries me very much because she has not included on the exchange lists at the moment and her health is deteriorating very quickly as a result of the severe beatings by SSU’s officers. In addition, Marina is under strong moral and psychological pressures as she is constantly transferred from the detention centre to the camp and back. They also constantly remind her that she would receive a very long sentence”, Larisa wrote a few days before she was sentenced.

One can only sympathise with those women, who have been in dungeons for more than three years. And admire their resilience and vitality! Hold on, girls! No one forgets about you!

“Readers’ Blogs” is a platform for free journalism and is not moderated by the editorial board. Users independently upload their materials onto the site. The editorial board does not share the opinions expressed by the bloggers, nor is it responsible for the accuracy of the facts stated by them.

Annex 81

BAGNET, *Kharkov terrorists may have been helped by police officers* (22 November 2014)

(translation)

Translation

BAGNET, *Kharkov terrorists may have been helped by police officers* (22 November 2014), available at: <https://www.bagnet.org/news/accidents/249149/harkovskim-terroristam-mogli-pomogat-rabotniki-militsii>.

Kharkov terrorists may have been helped by police officers

An internal investigation has been launched against a 50-year-old police officer, who has served 19 years in the police force

A Kharkov police officer illegally kept a sticking SPM mine at home, which is used to damage or destroy mobile and stationary objects.

According to the Ukrainian Internal Affairs Ministry's public relations department in Kharkov Region, this was discovered by officers of the regional internal affairs department and the Security Service Department for Kharkov Region when collecting information on individuals who may have been involved in terrorist and subversive activities.

"The day before, the police received intelligence that an officer of the internal affairs department was illegally storing dangerous items. The SBU and police officers carried out an inspection at the place of residence of the police officer in a private house, which resulted in the discovery and seizure of an SPM mine, which is classified as engineering ammunition. A criminal case has been opened and investigators are trying to find out where the mine was purchased and what was the purpose of keeping it," the statement said.

The statement notes that an internal investigation has been launched against the 50-year-old police officer, who has served in the police force for 19 years.

"The officer in question will be dismissed from the internal affairs department and held criminally liable," the regional police said in its statement.

As reported, a sticking SPM mine was seized when detaining members of the "Kharkov Guerrilla Fighters" sabotage group that was preparing explosions on the eve of the parliamentary elections. In addition, such mines were also used to carry out a number of terrorist attacks and acts of sabotage in Kharkov, including the bombing of a tank with aviation fuel and an explosion at Stena rock pub that injured 13 people.

Annex 82

Ukranews.com, *Kharkov Police Officer Kept Mine at Home* (22 November 2014)

(translation)

Translation

Ukranews.com, *Kharkov Police Officer Kept Mine at Home* (22 November 2014), available at: <https://ukranews.com/news/289036-kharkovskyy-mylycyoner-khranyl-doma-mynu>.

Kharkov police officer kept mine at home

The day before, the police received information that the officer was keeping dangerous items at home.

On 21 November, officers of the Internal Affairs Ministry's Main Directorate in Kharkov Region together with officers of the Security Service of Ukraine seized an SPM mine during an inspection of a private house in Kharkov in which a 50-year-old police officer lives. This was reported by the Internal Affairs Ministry's regional press service.

According to the report, law enforcers uncovered this fact when collecting information on persons who may be involved in terrorist and subversive activities.

The day before, the police received information that the officer was storing dangerous items at home.

Criminal proceedings have been opened in this connection, and investigators are now finding out the place and purpose of the munition acquisition.

"On the instructions of the head of the Internal Affairs Ministry's Main Directorate, an internal investigation has been launched against the 50-year-old police officer, who has served in the internal affairs agencies for 19 years. The officer will be dismissed from the internal affairs agency and held criminally liable," the statement said.

The mine found at the policeman's home is engineering munition used to damage or destroy moving and stationary objects.

As our news agency earlier reported, officers of the Internal Affairs Ministry's Department for Southern Railway found and seized abandoned bags with ammunition at Kharkov-Passazhyrsky railway station on 22 November.

Annex 83

Ukraine.ru, 11 years for a note. Political prisoner Kovtun convicted in Kharkov on falsified evidence (10 October 2019)

(translation)

Translation

Ukraine.ru, *11 years for a note. Political prisoner Kovtun convicted in Kharkov on falsified evidence* (10 October 2019), available at: <https://ukraina.ru/20191010/1025278110.html>.

11 Years for a Note. Political Prisoner Kovtun Convicted in Kharkov on Falsified Evidence

Vitaly Didenko

The SBU accused **Maryna Kovtun**, a Kharkov resident and member of the local Anti-Maidan movement, of working for the Russian special services. She was accused of offences under a number of articles of the Ukrainian Criminal Code: actions aimed at changing the state border (part 1 of Article 110), sabotage (part 2 of Article 28; Article 113), committing a terrorist act, leading a terrorist group (part 5 of Article 27; part 2 of Article 258; part 1 of Article 258-3; part 2 of Article 28), and the acquisition and storage of weapons and ammunition (part 1 of Article 32; part 1 of Article 263).

Explosion at Stena pub. SBU report on "Russian saboteurs" and Kovtun's arrest

On 9 November 2014, there was an explosion at Stena rock pub, which was known as a mass gathering place for nationalists of various stripes: ultras, "patriotic activists" and ATO members came there. The incident left 13 people injured, with no fatalities. In an interview with local media, the owner of the establishment described the incident as a terrorist attack and the reason for it as "aid to the Ukrainian military and refugees from Donbas".

A few days later, the SBU claimed that there was a "Russian trace" in the case, saying that SPM mines developed in the USSR had been used. Although a number of other media outlets claimed that an RGD-5 grenade, which might have been brought there by "warriors of light", exploded in the establishment.

On 17 November, the SBU reported that it had solved the high-profile case: 12 Kharkov residents were arrested, most of whom had undergone "sabotage training in Russia". The SBU press service said that AK-74 assault rifles and ammunition, RGD-5 and VOG-25 grenades, detonators, trip wire kits, and seven anti-personnel mines marked by Russian manufacturers were seized from the suspects.

A day later, a video emerged on the internet in which a woman confesses to the attack and to working for the "aggressor's" security services.

"During one of the trips, I was recruited by representatives of the Russian GRU. I was given the call sign Z and tasked with selecting members for a group from among anti-Maidan activists residing in Kharkov to commit acts of sabotage on the territory of Kharkov Region" she said.

This was Marina Kovtun, whom the SBU officers made the head of the non-existent "Kharkov Guerrilla Fighters" organisation. According to their version, the 48-year-old Kovtun, who worked as a seamstress, was trained to use explosives for two months. According to the investigation, in addition to the terrorist attack at Stena, the woman was allegedly implicated in two other similar incidents: explosions in a pit near the Malyshev Plant and near the Britannia restaurant.

The accused's relatives categorically denied this, claiming that the evidence had been beaten out of her under torture and threats to her family. For example, during a search, SBU officers detained five members of her family and stole money and valuables from her home. They stressed that the SBU officers knocked out the woman's teeth.

"Marina was on her way to see her parents, she often goes to see them, they are old in our family. She was driving with her nephew to the train station. She was stopped and arrested. Then they went further and arrested two more nephews. Then they arrested her son, then my son. The SBU took the car, by the way. She has absolutely nothing to do with this explosion. She didn't do anything like that. I saw her confession on the internet, I could hear it in her voice that she was in pain to talk. How could she have been beaten up, if I saw her after 4 weeks in the detention centre through 2 glasses and 2 bars, and one side of her face was just blue. I can imagine what happened to her then," her sister Larisa said.

An excruciatingly long process with dubious evidence

The investigation was completed in June 2015 - since then there has been a long trial. The indictment was sent to the Kiev District Court in Kharkov. Kovtun immediately retracted the initial testimony given during the pre-trial investigation, insisting that it had been extracted illegally. Understandably, numerous motions of the defence to change the measure of restraint were automatically rejected.

After three years of court hearings, in July 2018, the case began to be heard "from scratch", for after the chairwoman of the panel **Svetlana Shmadchenko** was dismissed, Judge **Denis Nevyadomsky** took her place. And in early 2019, Judge Nevyadomsky went on parental leave. Judge **Viktor Popras** took his place, but this time the hearing was continued.

Interestingly, most of the members of the "terrorist group" were sent to the Donbass republics during an exchange held in winter 2015, after which Kovtun was the only one left. The SBU and prosecutor's office insisted on her exclusion from this procedure under the pretext that "she has blood of Kharkov residents on her hands". Given the practice of mass imprisonment of citizens who hold "incorrect" political views from the authorities' point of view to fill the "exchange fund", which existed under Poroshenko's regime, Kovtun's "accomplices" were probably expelled from the country in this way to prevent the collapse of the convenient structure of the charges. After all, it is unlikely that real terrorists or saboteurs would have been released so easily.

The only accomplice who, according to the investigation, had brought the bomb to the pub, Ukrainian citizen **Dmitry Loginov**, fled the day after the explosion. In such case it is completely unclear how Kovtun could have been involved in the explosion near the Britannia restaurant allegedly carried out by Loginov.

The number of irregularities during the investigation was enormous. Let's begin with the weapons and ammunition allegedly belonging to the accused. They were discovered in the garage during a search for which there was no legal basis. The investigating judge legalised this action retroactively based on the testimony of the witness **Mineyev** and his signed authorisation to access the garage. In the meantime, the indictment states that the premises belonged to Kovtun herself. If Marina Kovtun is the owner of the garage, then on what grounds did Mineyev give permission to enter the garage?

The interrogation of the witness Mineyev was conducted before the information on the crime was entered into the Unified Register of Pre-Trial Investigations, although, under the Criminal Procedure Code, an investigation shall only begin when the data is entered into the unified register.

Incidentally, the search of the suspect's home took place immediately after the search of the garage and also without an order from the investigating judge. Not a single document or witness statement confirms that Kovtun was the owner of the weapon in

question. There were no fingerprints or traces of her DNA on it. The moment of finding the weapon and ammunition and moving them from the garage to the street is not recorded on video. There is no written record of the investigative action and its review by the suspect. The protocol of the investigative action was drawn up and signed later, not at the place and time of the investigative action.

The prosecutor's office referred to a note with telephone numbers found in Loginov's flat, which was written in Kovtun's handwriting, as the main evidence of her guilt. However, the sheet of paper with telephone numbers in no way suggests collusion to organise a terrorist attack, and it does not appear among the protocols attached to the case file.

The prosecution has not provided clear evidence that Kovtun joined the "Kharkov Guerrilla Fighters". This organisation does not exist, no one has recognized it as a terrorist organisation, and its likely members have not been questioned. Most likely, she is a figment of SBU's imagination. Several witnesses claimed that the suspect had undergone "sabotage training" on the territory of the Russian Federation. However, all of them are named in SBU's criminal cases, i.e. they are actually under its full control, so they are a priori biased. Such information cannot be supported by documents.

Kovtun's involvement in the explosion near the Malyshev Plant was justified with the help of a video seized from the accused's electronic media, where unknown persons were allegedly planting explosives. But it is not clear in the video itself who they are, what they are doing and where the action takes place.

The descriptions of the packaging in which the evidence seized from Kovtun was sealed do not match each other in different inspection reports in terms of dates and colour. This indicates that during the pre-trial investigation, SBU officers covertly accessed her belongings on numerous occasions. In addition, the amount of things seized from Kovtun (in the SBU office, according to the documents) (laptops, phones, video camera, etc.) is such that they could not be in her pockets. But on the video of detention she has no bag or backpack. This means that it was SBU representatives themselves who were taking the things to the police station and accessed them before the seizure was formalized. Thus, Kovtun's email box was accessed from her mobile phone, to which they also had uncontrolled access.

The protocols of covert investigative actions were drawn up by SBU officers who not only have no right to do so according to the Criminal Procedural Code, but who are also not members of the investigative team. The discs with the results of such actions

are not packaged or sealed and are not signed by the investigator and the prosecutor. In fact, they are copies of the original media, which means that they are inadmissible evidence under the Criminal Procedural Code.

It should be noted that the accused has been held in Kachanov penal colony No. 54 (Kharkov) for more than four years and was only taken to pre-trial detention facility No. 27 before court sessions. This fact is an outrage and a violation of human rights. The political prisoner repeatedly went on hunger strikes as a sign of protest.

The indictment was handed to Kovtun in a prison cell without the presence of a prosecutor and a lawyer, which is a sign of legal nihilism.

When conviction is not deliverance

Despite the above violations, the use of torture on the accused, and a large amount of dubious evidence obtained illegally, the court found Kovtun guilty under part 1 of Article 263 (illegal handling of weapons and ammunition) and part 1 of Article 258-3 (setting up a terrorist organisation) on the charges concerning the explosion in Stena rock-pub. The reasoning for the conviction in relation to this incident is based on a piece of paper with telephone numbers written in Kovtun's handwriting, which was found in the flat of Dmitriy Loginov, who, according to investigators, carried out the attack himself (he was outside Ukraine and, therefore, was not questioned in court).

Judges acquitted the suspect of the remaining charges (under part 1 of Article 110 (encroachment on territorial integrity), Article 113 (sabotage) and part 1 of Article 258-3 (setting up a terrorist organisation)) which pertained to the explosion at the Malyshev Plant and the Britannia restaurant.

By summing the terms of imprisonment under those articles of the Criminal Code in respect of which the court agreed with the prosecutor's office, the court gave Kovtun a cumulative sentence of 11 years' imprisonment (the prosecutor's office asked for 12 years). Taking into account Savchenko law, under which a day of pre-trial detention equals two days in prison, Kovtun served most of it. All in all, she has about a year to spend in custody.

However, the lawyer of the accused **Yevhen Olenov** noted that the verdict would be appealed against, not ruling out that his client would apply to the European Court of Human Rights. In this connection, we would like to hope that the ECHR will be able to reconsider the unjust verdict.

Thus, the verdict against Kovtun indicates that the Ukrainian judicial and law-enforcement system continues to act in a repressive and punitive way even under President **Zelensky**. The regime still breaks people's fates by keeping them behind bars for their political beliefs.

Annex 84

5140.org, *Baranenko Andrii Volodymyrovych* (25 January 2023)

(translation)

Translation

5140.org, *Baranenko Andrii Volodymyrovych* (25 January 2023), available at: <https://5140.org/wanted-people/639374673-baranenko-andrej-vladimirovich?ysclid=lb9xdz81py470992811>.

5140.ORG
UKRAINE

HOME

ORDER A SELECTION

PERSONAL DATA

Service of registers of Ukraine

Persons hiding from the court, prosecutor's office or pre-trial investigation bodies

Baranenko Andrii Volodymyrovych (1988-08-01)



Baranenko Andrii Volodymyrovych

Category: A person hiding from the pre-trial investigation bodies

The page has been extracted from the police search database (currently this person is no longer wanted).

Information about the search:

Internal Affairs Authority:
USBU office in Kharkiv region

Contact information:
057-700-9881

Gender:
Male

Date of Birth:
1988-08-01

Date of disappearance:

2015-02-15 (no longer wanted)

Place of disappearance:

Kharkovskaya, Kharkov

Wanted under the Article:

Article 3-258 part 1, article 263 part 1, article 258 part 2

Measure of restraint:

court order authorizing detention for the purpose of reporting, 22.09.2016

Annex 85

Anti-fascist, Kharkiv political prisoner Marina Kovtun is to be sentenced on 7 October. The prosecutor's office requested 12 years in prison (2 October 2019)

(translation)

Translation

Anti-fascist, Kharkov political prisoner Marina Kovtun is to be sentenced on 7 October. The prosecutor's office requested 12 years in prison (2 October 2019), available at: <https://antifashist.com/item/harkovskoj-politzaklyuchennoj-marine-kovtun-7-oktyabrya-oglasyat-prigovor-prokuratura-zaprosila-12-let-lisheniya-svobody.html>.

Marina Kovtun, political prisoner from Kharkov, will be sentenced on 7 October. Prosecutor's Office asks for 12 years in prison

02 October 2019 [Oksana Shkoda \(/item/oksana-shkoda.html\)](/item/oksana-shkoda.html)

A court hearing was held in Kharkov recently in the case of political prisoner Marina Kovtun, who has been in custody for almost 5 years without a court verdict. The 48-year-old Kharkov resident is charged with organising an explosion in the rock pub Stena (Rymarska Street) in Kharkov on 9 November 2014.

Let us recall that 13 people were injured in the explosion in the pub, which was a meeting place for various "nationalist activists" at the time. More than a dozen people whose names have been linked to the so-called "Kharkov Guerrilla Fighters" were detained on suspicion of committing this crime, but only Marina Kovtun went on trial.

During the court hearing, the prosecutor requested the maximum term of 12 years in prison for Marina Kovtun. This is despite the fact that under "Savchenko law" the political prisoner Kovtun is deemed to have already served 9 years in prison. The verdict is scheduled to be announced on 7 October 2019.

Seamstress Terrorist

Going back to Marina Kovtun's case, SBU officers detained her a week after the explosion in the Stena pub, on 16 November 2014. After brutally beating and torturing her, they forced the woman to incriminate herself. Thus, Marina Kovtun "confessed" to being an "FSB agent with the call sign 'Z' and a member of the terrorist organisation "Kharkov Guerrilla Fighters". As a result of the torture, Marina's teeth were knocked out and her facial muscles were damaged. We would like to stress that she is a seamstress by profession and participated in AntiMaidan demonstrations in Kharkov "on general grounds" in the spring of 2014.

In June 2015, the prosecutor's office of Kharkov Region submitted to the Kiev district court an indictment against Marina Kovtun, in which she was charged with acts aimed at violating the territorial integrity of Ukraine, changing the state border, sabotage, committing a terrorist act, leadership of a terrorist group and acquisition and storage

of weapons and ammunition (part 1 of Article 110; part 2 of Article 28; Article 113; part 5 of Article 27; part 2 of Article 258; part. 1 of Article 258-3; part 2 of Article 28; part 1 of Article 32; and part 1 of Article 263 of the Criminal Code of Ukraine). It should be emphasized that the entire bunch of crimes is imputed to a 48-year-old woman.

"The interrogation of prosecution witness Maxim lasted more than an hour. He earlier had undergone demolition and combat training in a camp in Tambov region at the same time as Marina Kovtun. The witness said that she had the call sign 'Z' and had been trained as a sniper; the training took about two weeks," the public relations department of Kharkov Region prosecutor's office said in November 2015.

In fact, such allegations form the basis of all the charges against Marina Kovtun, who has pleaded not guilty since the beginning of the trial and has repeatedly spoken of self-incrimination under torture. But despite everything, after a year spent in prison, Marina Kovtun has been held for more than four years in Kachanov penal colony No. 54 from which she is taken to SIZO (detention centre) No. 27 before each court session. She has repeatedly gone on hunger strikes, claiming that her rights have been violated. In the meantime, the Ukrainian side keeps refusing to include her in prisoner exchange lists. And since September 2018, Kovtun's case has been reheard from the very beginning by a new panel of judges. Lawyer Yevgeniy Olenev, who represents Marina Kovtun, is asking the court for an acquittal.

The case is "full of holes"

According to human rights activists of Uspishna Varta organisation, there are many inconsistencies in Marina Kovtun's case. For instance, proceedings in her criminal case were initiated on the very day her garage was searched on 16 November 2014, which indicates that no investigative actions had been carried out which would justify the need for an urgent entry into private property not sanctioned by the court. It was there, in the garage, that the weapons and ammunition were "found". The investigating judge legalised the search retroactively on the basis of testimony of a certain witness Mineyev who, in fact, gave permission to break into someone else's garage. In other words, the SBU officers entered Marina Kovtun's garage on the basis of Mineyev's testimony. However, there were no traces of Kovtun's DNA or her fingerprints on the weapons and explosives allegedly found in the garage.

The search of the political prisoner's home was carried out in the same illegal way - without an order of the investigating judge. Both searches took place without the investigative activity being documented in writing and without such documentation being reviewed by the suspect, and the records of the investigative activity were prepared and signed later, not at the place and time of the searches.

At the time of the searches, Marina Kovtun had already the status of a suspect. During the pre-trial investigation, SBU officers covertly accessed her belongings on numerous occasions.

Further, the prosecution has not yet provided evidence of Marina Kovtun's membership or leadership in the Kharkov Guerrilla Fighters. Moreover, there are no court rulings recognizing this organisation as a terrorist one. It is also unclear whether this organisation exists, since none of its members has been interrogated.

It should be stressed that Kovtun's case also contains numerous falsified (forged) telephone conversations, some notes allegedly written by the political prisoner herself, and videos of unknown people who, according to the investigation, planted explosives under Kovtun's direction. The suspect's email account was accessed from her mobile phone, which had been seized from her, and thus letters necessary for bringing charges against her were "prepared".

It is also known that the prosecution witnesses who said that Marina Kovtun "underwent terrorist training in a camp on Russian territory" are themselves under criminal investigation by the SBU, i.e. they are under investigators' control and, therefore, dependent on punitive agencies.

Annex 86

Interfax.ru, *PrivatBank branch shelled in Kharkov* (28 July 2018)

(translation)

Translation

Interfax.ru, *PrivatBank branch shelled in Kharkov* (28 July 2018), available at: <https://www.interfax.ru/world/388201>.

INTERFAX

14:51, 28 July 2014

PrivatBank branch shelled in Kharkov

Moscow. 28 July. INTERFAX.RU - In Kharkov on Monday night, unknown persons fired at a PrivatBank branch on Malomyasnytskaya Street.

As Tatyana Tkachuk, head of the regional press office of the Bank, told an Interfax correspondent, the incident took place at half past three in the morning. The shell hit the first floor but did not explode. Tkachuk did not specify what weapon was used for the shot. At the same time, social media users claim that an unpacked hand-held anti-tank grenade launcher was found near the building.

The regional police department has confirmed that the incident with the PrivatBank branch took place indeed.

As previously reported, there was a series of arson attacks on PrivatBank ATMs in Kharkov in late March. In April, "items resembling explosive devices" were found near the entrance to two PrivatBank branches. In both cases, the unknown items turned out to be imitations. In addition, two ATMs and a bank branch went up in flames in Kharkov on the night of 23 April. One of the owners of the Privat Group is a billionaire businessman and the head of the Dnepropetrovsk Region State Administration, Igor Kolomoyskyi.

Annex 87

Sm.news, *AFU uses MON-50, MON-100 and Claymore on drones* (24 December 2022)

(translation)

Translation

Sm.news, AFU uses MON-50, MON-100 and Claymore on drones (24 December 2022), available at: <https://sm.news/vs-ukrainy-nachali-ispolzovat-na-bespilotnikax-mon-50-mon-100-i-claymore-59590-u3t5/?ysclid=ldmzva075k431514547>.

AFU use MON-50, MON-100 and Claymore on UAVs

Svetlana Kok

December 24 - SM.News news agency. According to Avia.PRO news website, the Armed Forces of Ukraine have made unusual use of UAVs and directional anti-personnel mines.

Ukrainian army's large stockpile of MON-50 and MON-100 type anti-personnel mines and a large supply of U.S. Claymore mines allow the use of unusual attack tactics. It has become known that UAVs are equipped with anti-personnel mines, which turns them into weapons with a "kill zone" of up to 160 metres. Such a hybrid represents a particular danger. The only downside is the loss of the drone. It is noteworthy that the heavy weight of such mines makes it difficult to use them.

Annex 88

Ukraina.ru, *Gerashchenko Could Stage Attempt on Him* (22 January 2017)

(translation)

Translation

Ukraina.ru, *Gerashchenko Could Stage Attempt on Him* (22 January 2017), available at: <https://ukraina.ru/20170122/1018184795.html>.

Gerashchenko Could Stage Attempt on Him

Ukraina.ru 154.796editors@ukraina.ru +7 495 645 66 01 *Russia Today* 45260

The assassination attempt on Anton Gerashchenko was a profanation and feign, *Strana.ua* reports with reference to its source in the Security Service of Ukraine (SSU).

“This story has been prepared for a long time. Back in December, Gerashchenko’s people filed with the SSU a statement on a threat to his life. Based on that statement, he was allocated a guard consisting of two Alfa special-force soldiers. However, according to them, he behaved rather strangely and did not look like a person fearing for his life”, the source said.

Strana.ua also cited a Ukrainian businessman working with enterprises in the DPR and the LPR. He said Gerashchenko is directly involved in trading with the Donbass Republics – “they resolve many issues with him”.

Ukrainian media reported earlier that an assassination attempt was allegedly being prepared on Gerashchenko. The main motive was said to be his involvement in the creation of “Mirotvorets”, the scandalous website that publishes details of opponents of the current Ukrainian regime.

Annex 89

Sila v Pravde, *Attempt on Gerashchenko Was Feign Staged by SSU and Interior Ministry* (22

January 2017)

(translation)

Translation

Sila v Pravde, Attempt on Gerashchenko Was Feign Staged by SSU and Interior Ministry (22 January 2017), available at: <https://x-true.info/50402-pokushenie-na-geraschenko-inscenirovka-kotoruyu-gotovili-sbu-i-mvd.html>.

**Attempt on Gerashchenko Was Feign Staged by SSU and Interior Ministry
*Sila v Pravde: Up-to-Date International News***

MASTER



According to media reports, Avakov's adviser Anton Gerashchenko was supposed to be a victim of an assassination attempt prevented by the Security Service of Ukraine (SSU). However, sources in the SSU say the attempt on Gerashchenko may turn out to be a profanation and feign staged by the leadership of the SSU and the Ukrainian Interior Ministry whose head Mr. Gerashchenko was an associate of.

“This feign has been prepared for a long time”, one source said. “Back in December, Gerashchenko's people filed with the SSU a statement on a threat to his life. Based on that statement, he was allocated a guard consisting of two Alfa special-force soldiers. However, it immediately became clear to them that he did not really fear for his life because he said at the very first meeting that he would personally call the fighters when he saw fit – a strange behaviour for a person fearing an assassination attempt. And when the SSU was allegedly monitoring the criminals, Gerashchenko took no action. I mean, he also knew it was a feign”.

Furthermore, a Ukrainian entrepreneur dealing with the “DPR” and “LPR” notes Gerashchenko plays a significant role in providing a crime-sponsored cover for the semi-legal trade with those uncontrolled territories. “They resolve many issues with him by the code of criminals, including those concerning the carriage of coal. Maybe, he did not do something he promised to do at

some point but took money. So they decided to end with like criminals do. Maybe”, the entrepreneur suggests.

We may recall the contract murder was reportedly arranged by Andrei Tikhonov, a former citizen of Ukraine who now lives in Belgorod. The search database on the scandalous website “Mirotvorets” inspired by Mr. Gerashchenko contains details of Mr. Tikhonov. He is reported to be a deputy commander of an “LPR’s” separate commandant regiment and to have taken part in the capture of Nadiya Savchenko on 17 June 2014.

The main motives for the assassination attempt on Mr. Gerashchenko were allegedly his involvement in the creation of the “Mirotvorets” website and his anti-Russian attitude.

According to Vasyl Grytsak, the head of the SSU, several options for his murder were prepared. “The first option was to put an explosive device under his car. And the second option was to detonate an improvised explosive device along the path of his route”, Mr. Grytsak said.

Searches at the homes of the suspected perpetrators of the assassination attempt revealed a photo of the potential victim.

Annex 90

Ukrainski Novini, *Assassination Attempt on Gerashchenko Could Be Staged* (22 January 2017)

(translation)

Translation

Ukrainski Novini, *Assassination Attempt on Gerashchenko Could Be Staged* (22 January 2017), available at: <https://ukranews.com/news/473973-pokushenye-na-gerashhenko-moglo-byt-ynscenyrovano-smy>.

22 JANUARY 2017, SUNDAY, 10:13 AM

Assassination Attempt on Gerashchenko Could Be Staged, Media Report

By Olga Fandorina

According to media reports, Avakov's adviser Anton Gerashchenko was supposed to be a victim of an assassination attempt prevented by the Security Service of Ukraine (SSU). However, *Strana.ua* (<https://strana.ua/news/51480-pokushenie-na-gerashenko-mozhet-byt-inscenirovkoj.html>) claims, with reference to its sources in the SSU, the attempt on Gerashchenko could turn out to be a profanation and feign.

“This story has been prepared for a long time. Back in December, Gerashchenko's people filed with the SSU a statement on a threat to his life. Based on that statement, he was allocated a guard consisting of two Alfa special-force soldiers. However, according to them, he behaved rather strangely and did not look like a person fearing for his life”, the source said.

Furthermore, a Ukrainian entrepreneur dealing with enterprises in the so-called “DPR” and “LPR” notes Mr. Gerashchenko is involved in trading with those uncontrolled territories. “They resolve many issues with him. Maybe, he did not do something he promised to do at some point. So they decided to end with him. That is, I do not rule out the assassination attempt was really being prepared”, he suggests.

Ukrainski Novini reported earlier that the assassination attempt on a member of the Verkhovna Rada of Ukraine by Russian agents, the exposure of which was announced today by the SSU's Chair, was on Anton Geraschenko, a member of the People's Front (</news/473957-sbu-sorvala-pokushenye-na-nardepa-antona-gerashhenko-smy>).

Previously, it became known that the SSU prevented an attempt on a member of the Verkhovna Rada (</news/473909-sbu-predupredyla-pokushenye-na-zhyzn-odnogo-yz-deputatov-rady>).

Annex 91

Criminal Code of Ukraine, 5 April 2001

(excerpt, translation)

Excerpt
Translation

Criminal Code of Ukraine, 5 April 2001, available at:
<https://zakon.rada.gov.ua/laws/show/2341-14#Text>.

CRIMINAL CODE OF UKRAINE

Article 115. Premeditated murder

1. Murder, that is, intentional unlawful causing death on another person, - shall be punishable by imprisonment for a term of seven to fifteen years.
2. Premeditated murder:
 - 1) of two or more persons;
 - 2) of a young child or woman who was, to the knowledge of the perpetrator, pregnant;
 - 3) of a hostage or a kidnapped person;
 - 4) committed with special brutality;
 - 5) committed by a method that is dangerous to the lives of many persons;
 - 6) based on mercenary motives;
 - 7) based on hooligan motives;
 - 8) of a person or a person's close relative in connection with the performance of official or public duty by this person;
 - 9) in order to conceal another criminal offense or facilitate its commission;
 - 10) combined with rape or sexual assault;
 - 11) contracted murder;
 - 12) committed by a group of persons upon a prior conspiracy;
 - 13) committed by a person who has previously committed premeditated murder, with the exception of murder provided for in Articles 116 to 118 of this Code;
 - 14) based on motives of racial, national or religious intolerance, - shall be punishable by imprisonment for a term of ten to fifteen years or life imprisonment, with confiscation of property in the case provided for in subparagraph 6 of paragraph two of this article.

Annex 92

Slovo i Delo, *Assassination Attempt on Anton Gerashchenko. Was It Real?* (23 January 2017)

(translation)

Translation

Slovo i Delo, *Assassination Attempt on Anton Gerashchenko. Was It Real?* (23 January 2017), available at: <https://ru.slovoidilo.ua/2017/01/23/kolonka/igor-smaglyuk/pravo/pokushenie-na-antona-gerashhenko.-a-byli-malchik>.

Assassination Attempt on Anton Gerashchenko. Was It Real?

By Igor Smaglyuk, Security Expert, exclusively for Slovo i Delo

The Security Service of Ukraine (SSU) published a curious video. It allegedly confirms the serious intentions of two killers to eliminate Anton Gerashchenko, one especially patriotic member of the Verkhovna Rada of Ukraine. After watching this movie, we can draw a conclusion consonant with Mr. Shkiryak's recent statement on *Kniazhychi*: "Stink and calm down!". So it will be, Zoryan: we will stink, but we will not calm down.

Let us now go from irony to analysis. The video causes nothing but laughter. You can make such movies without leaving your home. If a special service really planned a murder of a statesman, that should be a whole special operation. The FSB is much easier to work in Ukraine as the country is flooded with its agents and those persons capable of performing such tasks. Such work must be carried out for years, with all planning being performed in one place (guess which one) – the object, his or her traffic schedules, the execution process, the escape, etc.

What do we see? Two guys wandering around the city, and we hear their comments about how difficult it is for them to get close to the object, how difficult it is to follow him, and, funnily, the discussion of escape routes. They are concerned about the cost of travelling to the border: \$100 or \$120! Conspiracy? No, they have never heard about it.

The choice of an explosive device as a method of elimination is quite interesting. The murder should take place on a guarded parking area, which complicated everything – the entrance is closed, plus there are guardians and video cameras there. But two professional killers discuss with their curators only this scenario – and no other one. If this option of elimination is chosen, the executor must be in the visual contact area, which, again, would complicate the process and require a clear escape scenario. But those guys are hoping for panic and two or three hours of handicap!

If we believe Zoryan Shkiryak's comment on the Russian trace, the executors would not count the money. That's at the least. They would discuss nothing on the way. And they would spit on the number of video cameras. Let us recall the murder of Pavel Sheremet. We know the end result, and it should be a matter of honour for Ukrainian law enforcement officers to solve such crime. But it is almost impossible to solve it. The performers were professionals who thought everything through to the smallest detail. For comparison, let us recall the ridiculous attempt on the ex-Prosecutor General Shokin, who was "shot" from a thermal imager. The assassination attempts on Shokin and Gerashchenko seem to have been thought through by the same "experts".

The comment on the detention of the perpetrators with an activated explosive device near Gerashchenko's house is a masterpiece. What crime did these two persons commit? An attempted murder? Illegal storage (penalised by two to five years in prison under Article 263(1) of the Criminal Code of Ukraine), provided the device is proved to belong to them. Or maybe

they found it three minutes ago on the road and were carrying it to the nearest police station?

Then we will learn the attackers were quietly tried so that no one from media could take part in the coverage of the high-profile trial. We will look forward to testimonies of the detainees and the complete and unconditional liquidation of the spy network in Ukraine: arrests of agents, residents and militants, and detections of caches with weapons and explosives.

The conclusions are self-explanatory. The assassination attempt on Gerashchenko is a banal cheap feign. What for? To raise the rating of the “People’s Front”, make people ignore the purchase of expensive Japanese cars for the police or distract their attention from the closure of the Lipetsk factory. Or for whatever other reason. Cheap PR events instead of professionalism and real struggle – that is all the current government is capable of. No word, no deed.

Annex 93

The Guardian, *Arkady Babchenko Reveals He Faked His Death to Thwart Moscow Plot* (2018)

Arkady Babchenko reveals he faked his death to thwart Moscow plot

Luke Harding

Arkady Babchenko, the Russian journalist whose murder was dramatically announced by [Ukraine](#) on Tuesday, emerged very much alive on Wednesday and said he had faked his own death in order to thwart a plot by Moscow to kill him.

Smiling, and looking a little sheepish, Babchenko appeared before a surreal press conference held by Ukraine's SBU security service. He apologised to his wife for the "nightmare" he had caused her but said there had been no alternative to playing at being dead.

"Olechka, I am sorry, but there were no options here," Babchenko declared. "I'm sorry for making you live through this. I've buried my own friends and colleagues many times myself."

Ukrainian officials announced on Tuesday that Babchenko, a veteran war correspondent, had been shot three times in the back as he left his apartment in the capital Kiev to buy bread. His wife discovered him lying in a puddle of blood and Babchenko died in an ambulance on the way to hospital, they said.

Ukraine's prime minister, Volodymyr Groysman, promptly blamed the Kremlin for Babchenko's "death" and suggested he had been targeted because of his professional work. To complete the picture, the authorities released a sketch of the likely assassin. It revealed a bearded middle-aged man wearing a baseball cap.

On Wednesday Babchenko revealed that this was all an elaborate special operation – a hoax, in fact. It certainly fooled the world's media, which reported his death prominently, and prompted friends and colleagues to shower him with posthumous tributes. At the time when he came back from the dead writers were busy crafting his obituary.

The news that Babchenko was alive and the sight of the reporter prompted gasps from journalists at the press conference. Speaking in Russian, for which he apologised, Babchenko said Ukraine's SBU had learned of a "serious" plan to kill him two months ago and warned him about it one month ago.

The plot originated in Moscow and from "government security services", he said. "They [the SBU] showed me evidence and I understood that it was coming from [Russia](#), probably from state security apparatus," Babchenko explained. He added: "They suggested I take part in a sting operation."

His apparent killers had been provided with his passport photo and official details, he said, hinting this was proof of Russian state conspiracy. The sting operation had its bizarre denouement on

Tuesday night when his death was announced. “I did my job. And I’m still alive,” Babchenko said, expressing thanks to Ukraine’s special services for “saving my life”.

▶▶▶ 'Murdered' Russian journalist turns up alive at news conference – video

There was near-universal relief at Babchenko’s miraculous resurrection, amid fears he had become the latest critic of Vladimir Putin to die in opaque circumstances. Babchenko had written for the liberal opposition newspaper Novaya Gazeta, six of whose correspondents have been murdered for real.

At the same time, fellow journalists were critical of Babchenko’s astonishing methods. He had, they argued, delivered a massive propaganda gift to the Russian government and its online army.

Officials in Ukraine and Russia routinely accuse each other of lying and fakery. In spring 2014 Putin annexed Crimea and fomented a conflict in eastern Ukraine, supplying weapons, tanks, and undercover soldiers to secessionist anti-Kiev rebels. More than 10,000 people have died, with both sides blaming each other for the fighting and its consequences.

Kremlin officials and Russia’s embassy in London had already blamed Ukraine for Babchenko’s “death”.

Russian trolls tweeted on Wednesday mocking reporters who had spread news of Babchenko’s demise.

One of those surprised by the reporter’s comeback was the British foreign secretary, [Boris Johnson](#), who had said on Tuesday he was “appalled” by Babchenko’s “murder”. The Foreign Office and British intelligence were seemingly unaware that his killing was a stunt until the news broke.

The Russian journalist Alexey Kovalev dubbed Babchenko “a total ass” and said “we’re all dunces for falling for this”. Kovalev added, in brackets: “I’m glad he’s alive, of course.”

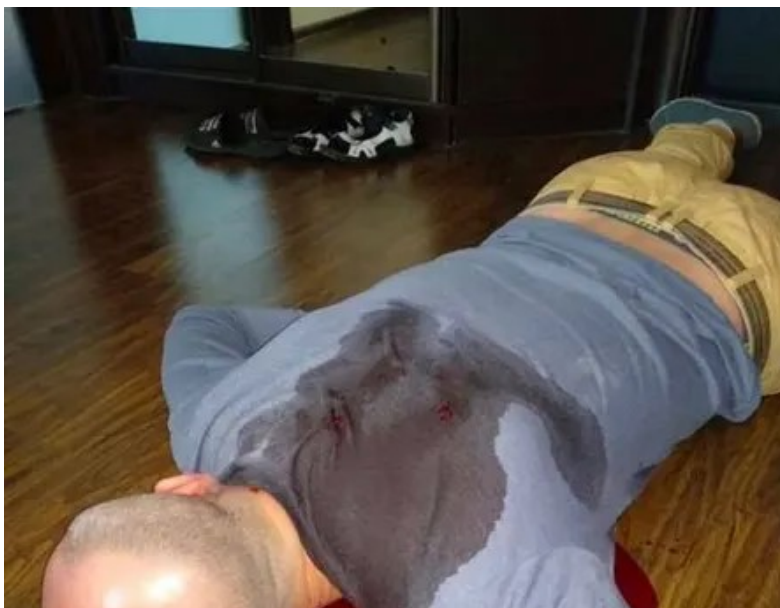



📹 Staged photograph of the ‘dead’ body of Arkady Babchenko. Photograph: Yevhen Lauer/east2west news

Andrei Soldatov, a Moscow-based writer and expert on Russia’s security services, said Babchenko had “undermined even further the credibility of journalists and the media”. In exasperated tones, he tweeted: “Babchenko is a journalist not a policeman, for Christ sake, and part of our job is trust, whatever Trump and Putin say about fake news.”

Garry Kasparov, the former world chess champion and opposition leader, was more forgiving. Kasparov – who moved to New York five years ago because of fears for his safety – called the episode “a bizarre charade”. “But I’ve had too many colleagues beaten and murdered to be anything but happy that he is alive and well,” he pointed out.

Details of the precise threat to Babchenko’s life were murky. Vasyl Hrytsak, the head of the SBU, said Russia’s spy agencies had contacted a middleman, identified only as G, and paid him \$40,000 to arrange the murder. The middleman in turn approached a former Ukrainian volunteer soldier to carry out the hit, together with additional “terrorist acts”, he said.

The middleman was now in custody, Hrytsak said, showing video of a middle-aged, white-haired man being bundled by officers into a van. Hrytsak added that phone intercepts had revealed his contacts in Moscow. Dozens of contract killings had been averted, he suggested, claiming that the list of potential victims in Ukraine stretched to 30 names.

The Ukrainian suspect was supposed to buy a large quantity of weapons and explosive, including 300 AK-47 rifles and “hundreds of kilos of explosives”, Hrytsak alleged.

The general prosecutor, Yuriy Lutsenko, appeared alongside Babchenko, who was dressed at Wednesday’s press conference in a black hoodie. Lutsenko said it was necessary to fake the journalist’s death so the organisers of the plot to kill him would believe they had succeeded.

📺 Colleagues of ‘murdered’ Russian journalist react upon seeing he is alive – video

Friends had begun planning vigils and fundraising for Babchenko’s adopted children when he emerged alive. Colleagues at the Ukrainian TV station where he worked – who had been watching the press conference live – whooped, danced and clapped in disbelief when it emerged he was still

among the living.

Babchenko left Moscow in February 2017 and settled with his wife and family in Ukraine. He escaped – in his words – following a sustained campaign of vilification by Russian state TV channels and by pro-Putin politicians. Babchenko, who fought in both the first and second Chechen wars, had written a Facebook post saying the crash of a Russian military plane on its way to [Syria](#), killing all on board, left him indifferent.

Tens of thousands of people signed a petition to strip him of his Russian citizenship and Babchenko's home address was published on line. In a piece for the Guardian [Babchenko wrote](#): “Like many dissidents I am used to abuse, but a recent campaign against me was so personal, so scary, that I was forced to flee.”

In March Babchenko attended an anti-Kremlin conference in New York. He described “propaganda” as Putin's greatest weapon and said it was more powerful than a “plane or a tank”. Russia's president had used the media to “dehumanising” effect, he argued, portraying Chechens, Ukrainians and liberal protesters as “enemies”.

Annex 94

The Guardian, *Ukraine Clashes: Dozens Dead after Odessa Building Fire* (2014)

Ukraine clashes: dozens dead after Odessa building fire

Howard Amos

More than 30 people were killed in violent and chaotic clashes in the southern Ukrainian city of Odessa on Friday as pro-Ukraine activists stormed a building defended by protesters opposed to the current government in Kiev and in favour of closer ties with Russia.

The violence continued on Saturday as Ukraine said its forces had attacked pro-Russian separatists in the industrial east of the country at dawn near the town of Kramatorsk.

Interior minister Arsen Avakov said Ukrainian forces had seized control of a television tower in Kramatorsk, near the rebel stronghold of Slavyansk where there was heavy fighting on Friday. "We are not stopping," Avakov wrote on his Facebook page, but gave no information on casualties.

Odessa's large Soviet-era trade union building was set alight on Friday as the pro-Ukraine activists mounted an assault as dusk fell. Police said at least 31 people choked to death on smoke or were killed when jumping out of windows after the trade union building was set on fire.

Bodies lay in pools of blood outside the main entrance as explosions from improvised grenades and molotov cocktails filled the air. Black smoke from the building and a burning pro-Russia protest camp wreathed the nearby square.

Pro-Russia fighters mounted a last-ditch defence of the burning building, throwing masonry and petrol bombs from the roof on to the crowd below.



📷 A pro-Russia activist aims a pistol at supporters of the Kiev government during clashes in the streets of Odessa. Photograph: Sergey Gumenyuk/Reuters

Medics at the scene said the pro-Russia fighters were also shooting from the roof. At least five bodies with bullet wounds lay on the ground covered by Ukraine flags as fire engines and

ambulances arrived at the scene.

Some people fell from the burning building as they hung on to windowsills in an attempt to avoid the fire that had taken hold inside. Pro-Ukraine protesters made desperate efforts to reach people with ropes and improvised scaffolding.

"At first we broke through the side, and then we came through the main entrance," said one pro-Ukrainian fighter, 20, who said he was a member of the extreme nationalist group Right Sector.

"They had guns and they were shooting ... Some people jumped from the roof, they died obviously," he said.

Riot police arrived on the scene as hand-to-hand fighting was already under way inside, but did not enter the building and stood formed up in ranks outside.



📷 A protester walks past a burning pro-Russia tent camp near the trade union building in Odessa. Photograph: Yevgeny Volokin/Reuters

Within two hours of the assault beginning, the resistance from pro-Russia activists inside the building seemed to have been quelled. Several fire crews were spraying the smouldering building with water and ambulances lined the streets outside.

Bloody and dazed pro-Russia protesters were eventually escorted from the building. Many were handed over to police, and loaded on to police vans. Some were assaulted by the crowd.

"The aim is to completely clear Odessa [of pro-Russians]," said Dmitry Rogovsky, another activist from Right Sector whose hand had been injured during the fighting. "They are all paid Russian separatists."

The seizure of the trade union building was the violent culmination of a day of street battles in this Black Sea resort city.

The clashes reportedly began after protesters gathering for a rally in support of a unified Ukraine were attacked by pro-Russia activists armed with clubs and air pistols.

But the confrontation quickly escalated into a series of skirmishes as the two sides played a deadly

cat and mouse game in the centre of the city.

Police largely stood aside as the two sides hurled molotov cocktails, cobblestones and bricks at each other. Girls as young as fourteen were smashing cobblestones to break them up into missiles of a manageable size.

Combatants on both sides were armed with body armour, helmets and shields and carried baseball bats, chains, metal bars and air pistols.

For two and a half hours the police were absent, said Olga Gold, a teacher watching the unrest. "The authorities have been absolutely indifferent," she said.

Dozens of buildings and cars were damaged during the violence. Most of the cafes and bars in central Odessa, a popular holiday spot, were closed by early evening.



📷 A wounded man is treated after clashes in Odessa. Photograph: Sergey Gumenyuk/EPA

Meanwhile in the east of the country on Friday [Ukrainian military forces mounted their fiercest attempt yet to retake Slavyansk](#) – the town at the centre of the pro-Russia insurrection – obliterating checkpoints and losing two helicopters in an assault that has tilted the country closer to outright conflict.

At least two Ukrainian crewmen died when the Mi-24 helicopters were brought down by sophisticated missiles, and Stella Khorosheva, a spokeswoman for the insurgents, said three fighters and two civilians were killed in the clashes.

The claims could not be verified but the escalation resulted in the deadliest day in Ukraine since a dozen towns and cities fell to pro-Russia gunmen last month.

On Friday night, Slavyansk was calm but tense as pro-Russia gunmen regrouped in the rain.

Moscow responded by calling for a special UN security council meeting, [saying the deal agreed in Geneva two weeks ago to defuse the situation had been buried by the Ukrainian onslaught](#). "The Kiev regime moved combat air forces against peaceful settlements, began a reprisal raid, essentially finishing off the last hope for the feasibility of the Geneva accords," said Dmitry Peskov,

spokesman for Vladimir Putin. But there were no indications of an imminent Russian invasion. Instead, Moscow sent an envoy to try to help release foreign military observers who have been held hostage in the city.

The sudden escalation dominated exchanges between Barack Obama and Angela Merkel in Washington. The US and Europe have sought to coordinate their response to the crisis, imposing two rounds of sanctions aimed at Putin's inner circle and freezing assets of companies linked to them. [On Friday they warned Russia that sanctions targeting whole sections of the country's economy would be inevitable](#) unless Moscow de-escalates the situation in Ukraine before elections later this month.



📹 Barack Obama and Angela Merkel hold a joint news conference in the Rose Garden.
Photograph: Alex Wong/Getty

"Putin's views must be taken into account in Ukraine, but Russia does not have the right to violate Ukrainian territorial integrity or dictate Ukrainian domestic policy," Obama said.

Merkel also gave a strong endorsement of potential new sanctions. "In [Europe](#), we have taken a position that should further destabilisation happen, we will move to a third stage of sanctions," she said.

Annex 95

BBC News, *Ukraine Crisis: Russia Condemns Attack on Kiev Embassy* (2014)

Ukraine crisis: Russia condemns attack on Kiev embassy

BBC News

Protesters threw eggs and rocks and smashed cars

Russia has reacted angrily to a violent protest outside its embassy in Ukraine, which saw windows smashed, the Russian flag torn down and cars overturned.

Russia accused Ukrainian police of doing nothing to stop the attack, and called it a "grave violation of Ukraine's international obligations".

Meanwhile Nato released images which it says back up Ukrainian claims that Russian tanks crossed into Ukraine.

Moscow has denied sending the tanks to help pro-Russian rebels in the east.

A range of images show the T-64 tanks first at a Russian military staging area near Rostov-on-Don, and then apparently inside Ukraine earlier this week.

Unlike Ukrainian armoured vehicles, the tanks have no markings or camouflage.

Nato says the pictures "raise significant questions" about Russia's role in eastern Ukraine.



Other

A lone T-64 battle tank is shown in Snizhne, Ukraine, with no markings

Analysis: Jonathan Marcus, BBC diplomatic correspondent

Now [Nato has released satellite imagery](#), linked to existing video material, which appears to give added weight to assertions from the Ukrainian authorities that the tanks used by separatist forces

that crossed into its country just a few days ago were indeed supplied by the Russians.

The evidence shown comes from Nato military sources and is not necessarily conclusive. But, despite Russian denials, it is strongly suggestive of the narrative that Nato is setting out.

It should be noted that Russian spokesmen have denied a number of things in regard to operations in Ukraine which have turned out to be untrue.

Saturday's disturbance in Kiev occurred when several hundred protesters hurled eggs and paint at the Russian embassy.

One petrol bomb was also hurled, windows smashed and flags torn down.

The protesters - some wearing balaclavas - overturned cars with diplomatic plates. One protester held a sign saying: "Russia is a killer."



AP

The protesters destroyed diplomatic vehicles and smashed windows

Russia's protest against the incident was echoed by the US state department. "The United States condemns the attack on the Russian embassy in Kiev, and calls on Ukrainian authorities to meet their Vienna convention obligations to provide adequate security," it said.

Retaliation threat

Earlier on Saturday, Ukrainian President Petro Poroshenko vowed to retaliate against pro-Russia separatists in the east after a military plane was shot down by anti-aircraft fire, killing all 49 people on board.

Those involved in such "cynical acts of terrorism" must be punished, said Mr Poroshenko, who summoned security officials for an emergency meeting.

The Ilyushin-76 transport was attacked by separatist forces as it was about to land in the city of Luhansk.

Pro-Russian fighters have been searching the site for useable ammunition, as David Stern reports

It is thought to be the biggest loss of life suffered by government forces in a single incident since the Ukrainian government in Kiev began an operation to try to defeat the insurgency in the east.

Rebel fighters were seen combing through the charred wreckage of the plane, south-east of Luhansk, on Saturday.

"This is how we work," one of them, who identified himself as Pyotr, told Reuters news agency.

"The fascists can bring as many reinforcements as they want but we will do this every time."

The incident came less than a week after pro-Russia rebels launched a series of attacks on Ukrainian forces at Luhansk International Airport.

The airport has been under the control of government forces but the rebels hold most of the rest of the city.

The eastern regions of Donetsk and Luhansk declared independence last month. In March Russia annexed the Crimean peninsula in the wake of the removal of Ukraine's pro-Moscow President Viktor Yanukovich.

The "anti-terrorist operation" by Ukrainian government forces has left at least 270 people dead over the past two months.

Mr Poroshenko had said that fighting must end "this week" following his inauguration last Sunday.



Annex 96

NV, *"Where it will be comfortable." Kremlin called on opponents of the language law to leave Ukraine* (6 August 2021)

(translation)

Translation

NV, "Where it will be comfortable." Kremin called on opponents of the language law to leave Ukraine (6 August 2021), available at <https://nv.ua/ukr/ukraine/events/movniy-zakon-taras-kremin-zaklikav-protivnikiv-zakonu-zalishiti-ukrajinu-50176123.html>

"Go where you will feel comfortable". Kremin calls on opponents of the language law to leave Ukraine

6 August 2021, 22:17

Ukrainian language ombudsman Taras Kremin called on those who oppose the language law of the Ukrainian state to leave the country. He posted on Facebook his speech on Channel 4.

Kremin quoted a decision of the Constitutional Court of Ukraine saying that a threat to the Ukrainian language is tantamount to a threat to national security and the existence of the Ukrainian nation and state.

"Those who are not satisfied with the Ombudsman, the language law or the Ukrainian state: put all these thoughts into words before you go to another country where you think you will feel comfortable. If you have Ukrainian citizenship and access to media resources and if you can pursue your educational, professional, and social trajectory here, please respect the Constitution of Ukraine, the laws of Ukraine, and the Ukrainian people," Kremin said.

The Ombudsman reminded that Ukrainians have been fighting for their independence for centuries and continue to fight the occupiers in Donbas.

On 16 July, a number of provisions of the law on language came into force in Ukraine. According to these provisions, Ukrainian TV channels must ensure that films and TV series (and individual episodes) are broadcast in the state language.

The Law of Ukraine *On Ensuring the Functioning of the Ukrainian Language as State Language* came into force on 16 July 2019. The entry into force of many of the provisions of the law was postponed to different dates. In particular, Article 30 on the Ukrainian language in the sphere of consumer services came into force in January 2021.

On 14 July, the [CCU declared the law on language constitutional](#). The request to consider whether it was constitutional had been made by 51 people's deputies, members of the Verkhovna Rada of the previous convocation, who mostly included former members of the Opposition Bloc.

Annex 97

Law of Ukraine No. 2827–IX “On National Minorities (Communities) of Ukraine”,
13 December 2022

(excerpt, translation)

**Excerpt
Translation**

Law of Ukraine No. 2827–IX “On National Minorities (Communities) of Ukraine”, 13 December 2022, available at: <https://zakon.rada.gov.ua/laws/show/2827-20#Text>.



LAW OF UKRAINE

On National Minorities (Communities) of Ukraine

The Verkhovna Rada of Ukraine,

based on the interests of the Ukrainian people, citizens of Ukraine of all nationalities, regarding the development of a sovereign, independent, democratic, social, and rule-of-law state,

based on the [Constitution of Ukraine](#) and the [Declaration of the Rights of Nationalities of Ukraine](#) and being guided by the provisions of the [Council of Europe Framework Convention for the Protection of National Minorities](#), the [European Charter for Regional or Minority Languages](#), and other international treaties on the rights of persons belonging to national minorities (communities) of Ukraine, which have been ratified by the Verkhovna Rada of Ukraine,

striving to create appropriate conditions for the exercise and protection of the rights of all persons belonging to national minorities (communities) of Ukraine; the preservation and development of their linguistic, cultural, ethnic and religious identity; and ensuring their proper development as part of Ukrainian society,

respecting cultural diversity and encouraging intercultural dialogue with a view to developing mutual understanding, mutual respect and cooperation between all persons residing within the territory of Ukraine, regardless of ethnic, cultural, linguistic or religious background,

with a purpose of ensuring equality of Ukrainian citizens regardless of ethnic origin, and

with a purpose of consolidating the Ukrainian nation,

adopts this Law in order to define the specific features of social relations in ensuring the enjoyment of rights and freedoms by persons belonging to national minorities (communities) of Ukraine.

[...]

Section II. RIGHTS, FREEDOMS AND OBLIGATIONS OF PERSONS BELONGING TO NATIONAL MINORITIES (COMMUNITIES)

Article 5. Rights, freedoms and obligations of persons belonging to national minorities (communities)

1. Citizens of Ukraine, regardless of ethnic origin or their belonging to national minorities (communities) are guaranteed equal civil, political, social, economic, cultural and linguistic rights and freedoms as defined by the [Constitution of Ukraine](#).

2. A person belonging to a national minority (community) also shall have the right to:
 - 1) self-identification;
 - 2) freedom of public associations and peaceful assembly;
 - 3) freedom of expression of their views and beliefs and freedom of thought, speech, conscience and religion;
 - 4) participation in political, economic and social life;
 - 5) use of the language of a national minority (community);
 - 6) education, in particular in the languages of national minorities (communities);
 - 7) preservation of the cultural identity of a national minority (community).
3. The list of rights enjoyed by persons belonging to national minorities (communities) defined in **part two** of this Article is not exhaustive. Other rights and freedoms may be granted to such persons in accordance with the law.
4. A person belonging to a national minority (community) may exercise the rights and freedoms guaranteed by this Law, individually or jointly with other persons belonging to national minorities (communities) on the territory of Ukraine.
5. A person belonging to a national minority (community) shall comply with the **Constitution** and the laws of Ukraine; defend the state sovereignty and territorial integrity of Ukraine; respect the language, culture, traditions, customs, religious identity of the Ukrainian nation and of all national minorities (communities) and indigenous peoples of Ukraine; and promote the integration of their national minority (community) into Ukrainian society.
6. The rights and freedoms of persons belonging to national minorities (communities) may be restricted in accordance with the law, if such restriction is necessary in a democratic society.

In the exercise and/or protection of the rights and freedoms of persons belonging to national minorities (communities), it is prohibited to promote or publicize a terrorist state (aggressor state) or its bodies; the Russian Nazi totalitarian regime or symbols of the military invasion of Ukraine by the Russian Nazi totalitarian regime; representatives of the authorities of a terrorist state (aggressor state) and their actions that create a positive image of the terrorist state (aggressor state) and justify or recognise the legitimacy of the armed aggression of the Russian Federation as a terrorist state against Ukraine or the occupation of the territory of Ukraine.

[...]

Annex 98

Krymsky Analitik, *Photos. Crimean Tatars Demand that Yushchenko and Tymoshenko Stop Racial Discrimination in Ukraine* (18 May 2009)

(translation)

Translation

Krymsky Analitik, Photos. Crimean Tatars Demand that Yushchenko and Tymoshenko Stop Racial Discrimination in Ukraine (18 May 2009), available at: <http://www.agatov.com/content/view/1451/19/>.

Krymsky Analitik

PHOTOS. CRIMEAN TATARS DEMAND THAT YUSHCHENKO AND TYMOSHENKO STOP RACIAL DISCRIMINATION IN UKRAINE

Photos. Crimea. Yevpatoria. 18 May 2009. At a mourning rally dedicated to the deportation of Crimean Tatars from Crimea, Crimean Tatars demanded that Ukrainian President Viktor Yushchenko and Ukrainian Prime Minister Yulia Tymoshenko stop the racial discrimination and apartheid against the Crimean Tatar people.

In addition, they demanded that the Ukrainian authorities restore the rights of the Crimean Tatar people as an indigenous people of Crimea, ensure the political representation of Crimean Tatars in all authorities of Crimea and Ukraine, enable the soonest return of Crimean Tatars from places of deportation to their homeland – Crimea, give the Crimean Tatar language the status of a state language in Crimea, compensate the Crimean Tatar people in full for the damage caused by the deportation, restore the historical toponyms of the Crimea, legalise the land plots occupied by the Crimean Tatars, and stop the economic exploitation and cultural assimilation of the indigenous people. Interestingly, the accusations of racial discrimination, apartheid, economic exploitation and cultural assimilation of the indigenous people of Crimea were directed to the leader of Our Ukraine, Ukrainian President Viktor Yushchenko, whom the leaders of the Mejlis of the Crimean Tatar People urged Crimean Tatars to vote for during the presidential and parliamentary elections in Ukraine. Moreover, the leaders of the Mejlis knew that Our Ukraine and Ukrainian President Viktor Yushchenko would never give up their principles: one people, one language, Ukrainian, for all, and one faith.

Having deceived the people during the elections, yesterday's agitators for Our Ukraine today actually accused this political force from which Mustafa Dzhemilev, the leader of the Mejlis was elected to the Ukrainian Parliament, of racial discrimination, apartheid, economic exploitation, and cultural assimilation of the indigenous people of Crimea.

Local observers believe such a tough resolution of the rally which the vast majority of Crimean Tatars voted for indicates a change in the political orientation of the Mejlis' leadership. It is possible that the Mejlis will call for voting not for Ukrainian President Viktor Yushchenko but for Ukrainian Prime Minister Yulia Tymoshenko in the upcoming presidential elections in Ukraine. Moreover, they will campaign for her despite the fact that she has submitted to the Verkhovna Rada of Ukraine, which is harshly criticised by the Crimean Tatars' leaders, the draft Ukrainian Law "On the Restoration of the Rights of Persons Deported on Ethnic Grounds".

The mourning rally in Yevpatoria took place in a well-organised and quite peaceful manner under the protection of the Ukrainian police. Andrey Danilenko, the Mayor of Yevpatoria, spoke at the rally and laid flowers at the monument to the victims of deportation.

Krymsky Analitik publishes 37 photos taken by Crimean paparazzi at the mourning events in

Yevpatoria.



Annex 99

Ukraina.ru, “*Dzhemilev and Western countries try to prevent Crimea from joining Russia* (28 November 2014)

(translation)

Translation

Ukraina.ru, *Dzhemilev and Western countries try to prevent Crimea from joining Russia* (28 November 2014), available at: <https://ukraina.ru/20141128/1011319376.html>.

Dzhemilev and Western countries try to prevent Crimea from joining Russia



16:43 28.11.2014
© RIA Novosti . Grigory Vasilenko

Vasip Muravitsky

Author Ukraina.RU

Our author Vasip Muravitsky on the threat of inter-ethnic conflicts

On 2 November, Mustafa Dzhemilev said that he was going to set up a Crimean Tatar territorial defence battalion. He said that he had talked to Ukrainian President Petr Poroshenko about it. Dzhemilev said that about 450 ethnic Crimean Tatars were fighting on the side of Kiev's forces in Donbass and that their families in Crimea were in danger. That is why the names of these Tatars should be kept in confidentiality. At the same time, Dzhemilev handed over to the Prosecutor General's Office of Ukraine a list of almost 400 people who allegedly violate human rights in Crimea.

Fearing for the families of the warring Tatars, he at the same time denounced his opponents to the Prosecutor General's Office, whose relatives may be in mainland Ukraine. Making a statement about the planned creation of an ethnic battalion, which the German newspaper Der Freitag quoted the ARD television channel as calling an "Islamic State" battalion, Dzhemilev did not fail to say that the future of the Crimean Tatar people is "an independent and strong Ukraine". Today, Al-Jazeera came out with another publication where it repeated all the myths about the Crimean Tatars: as if they are being mercilessly oppressed, kidnapped, and prevented from developing their culture. The publication, quoting the Tatar detainees whose homes were searched, forgets to mention that they are all members of a radical Islamist organisation banned in the homeland of Al-Jazeera's founders.



© RIA Novosti . Konstantin Chalabov

Tatar "refugees" from Crimea - representatives of radical Hizb-ut-Tahrir

Organisations such as Hizb-ut-Tahrir and the Mejlis in Crimea have clashed over the conflict of ideas of statehood in recent years. Hizb-ut-Tahrir radicals, which are banned in many countries, including Russia, and are permitted in Ukraine, want to build a worldwide Islamic Caliphate, where the Caliph will revive Islam on earth. The Mejlis has clashed with the Hizbis not only for power, but

also on ideological grounds: Dzhemilev and Chubarov's organisation dreams of building a national state for the Crimean Tatars and in no way an independent and strong Ukraine.

When Crimea became part of Russia, it became subject to the laws of the Russian Federation, one of which prohibits Hizb-ut-Tahrir from operating on the territory of the state. That's when Tatar "refugees" from Crimea, so pampered by the Ukrainian TV channels in Kiev, started streaming in. The Kiev media showed the "suffering" of the humiliated Tatars but did not show the fact that against the background of anti-Russian hysteria with Crimea, the Tatars did not stay in Ukraine but began to emigrate to EU countries, such as Germany, where the Turkish community is large and close to them.

Meanwhile, the aforementioned Al-Jazeera and most Ukrainian and even Russian media outlets present the Mejlis as the unconditional spokesperson for Tatar interests, which is far from the case

The Mejlis does not represent the entire Crimean Tatar people

The Mejlis is a political organisation founded during the Soviet era, something akin to Vyacheslav Chernovol's People's Rukh of Ukraine. This structure represented the Crimean Tatar people only to increase nationalist tendencies in the USSR and while at the time of the collapse of the Soviet Union the Mejlis was supported by over 90%, the number of supporters of Dzhemilev and Refat Chubarov's structure has now fallen sharply. In 2013, the Mejlis was opposed by the Tatar organizations Mili Firka and radical Hizb ut-Tahrir, which later emigrated from the peninsula after Crimea's accession to Russia. For example, prominent Crimean Tatar politician Vasvi Abduraimov recently stated that "in the early 1990s this support [for the Mejlis] was 90%, today it is 18%. These 18-20% of Crimean Tatars probably support Euromaidan, 60-70% are apolitical and are engaged exclusively in issues of survival and maintenance of their families because they started living in

Crimea with different background, unlike everyone else, and somewhere around 10-15% are actively against Euromaidan".



© RIA Novosti . Taras Litvinenko

Even these facts help to understand that not all Tatars support the Mejlis, and if we take into account that there are only about 300,000 representatives of this ethnic group on the peninsula, the real support for the Mejlis is not significant at all.

Dzhemilev is a Ukrainian politician. Not a Tatar one...

Mustafa Dzhemilev has never been a Crimean Tatar national politician. He began his career as an anti-Soviet politician, a dissident, and never changed his political platform. He is not interested in real representation of Crimean Tatar interests as his goal is to destroy the common Russian-Ukrainian cultural and economic space. That is why Mustafa Dzhemilev has spent his entire political life not in Crimea, but in Kiev as a member of one or another Ukrainian nationalist political party. It may seem surprising, but Mustafa Dzhemilev is a Ukrainian nationalist politician of Crimean Tatar origin and has no right to represent the once nomadic ethnic group. Moreover, Dzhemilev is one of the most "experienced" members of the Verkhovnyaya Rada, the parliament of

Ukraine, and spent most of his time even before being expelled from Crimea not on the peninsula but in Kiev.



© RIA Novosti . Evgeny Kotenko

Having been in the central vertical of power for more than 20 years as a people's deputy, Dzhemilev was unable or unwilling to achieve an official status for the Crimean Tatar language on the peninsula. Moreover, not even decent textbooks for teaching the language in schools have been created during these years. The Mejlis was once the presidium of the Qurultay, a congress of representatives of the Crimean Tatar people. But the Mejlis did not fulfil real representative interests for long, only a few years from 1990. Then the Mejlis was literally privatized and became a private structure of Mustafa Dzhemilev's political interests.

Dzhemilev, who criticises Russia, is afraid to mention the fact that Crimean Tatar is now one of the three official languages of the peninsula, Crimean Tatar holidays are official weekends and the Qurultay has received state recognition for the first time in 20 years of Tatar return to Crimea. What prevented Mustafa Dzhemilev from obtaining official rights for the Qurultay throughout Ukraine's independence and what enabled Russia to do this? The answer is simple: Mustafa Dzhemilev never had this issue as a priority.

Dzhemilev's assertion that the future of the Tatars lies in a strong and independent Ukraine is a huge amount of deceit. The Mejlis' platform, unlike that of Hizb-ut-Tahrir, contains ideas of building

a strong and independent Crimean Tatar state. It is logical to think that it is also potentially independent from Ukraine.

Dzhemilev's assertion that the future of the Tatars lies in a strong and independent Ukraine is a huge amount of deceit. The Mejlis' platform, unlike that of Hizb-ut-Tahrir, contains ideas of building a strong and independent Crimean Tatar state. It is logical to think that it is also potentially independent from Ukraine.

On 1 January 2015, a further, seemingly inevitable, complete administrative and legal merger of Crimea and Russia will begin. Dzhemilev's aggravated speeches and Western support for him are precisely linked to this fact.

Mustafa Dzhemilev is an agent of Western influence, but not of the Crimean Tatar people. Real representatives of this ethnos should appear very soon, not pro forma ones.

Annex 100

Sprotyv.info, *Traitors will flee Crimea even sooner than Russian soldiers - Chubarov*
(8 May 2017)

(translation)

Translation

Sprotyv.info, *Traitors will flee Crimea even sooner than Russian soldiers - Chubarov* (8 May 2017), available at: <https://sprotyv.info/news/predateli-sbegut-iz-kryma-eshhe-bystree-chem-rossijskie-soldaty-chubarov/>.



Traitors will flee Crimea even sooner than Russian soldiers - Chubarov

08:30 | 08.05.2017

Traitors from occupied Crimea who supported Russia will be the first to flee the peninsula during its liberation.

This opinion was expressed by the head of the Mejlis, people's deputy Refat Chubarov, according to eizvestia.com.

In his words, the annexation of Crimea has divided the Crimean Tatar population into people who have their own dignity and those who are actually "cunning people who are ready to sell themselves and others every day".

However, Chubarov adds, the latter will disappear from Ukrainian Crimea even faster than Russian soldiers.

"This is not to say that we will immediately find an understanding there as to where to start mopping up Crimea and building a society that will be acceptable for everyone. It will take several years to prepare the situation regarding local elections, several years for Crimea to come to its senses, according to Ukrainian laws," Chubarov believes.

Earlier, the IS ("Informacijnij Sprotyv") group reported that Crimea failed to receive "crowds of tourists" for the May holidays.

Annex 101

Bigmir.net, *Chubarov: It is necessary to establish criminal liability for collaborators* (10 April 2016)

(translation)

Translation

Bigmir.net, Chubarov: It is necessary to establish criminal liability for collaborators (10 April 2016), available at: <https://news.bigmir.net/ukraine/4699499-cubarov-nuzno-vvesti-ugolovnyu-otvetstvennost-dlya-kollaborantov>.

Chubarov: It is necessary to establish criminal liability for collaborators

According to the Mejlis leader, a definition of collaboration should be added to the Criminal Code, as well as changes to the penalties for treason.

10 April 2016, 23:09



The head of the Mejlis of the Crimean Tatar people Refat Chubarov believes that it is necessary to improve the criminal legislation of Ukraine to prosecute citizens for collaborationism. This is reported by Krym.Realii.

According to Refat Chubarov, these provisions are necessary for the legal assessment of the actions of those who cooperate with the occupation authorities in the occupied territories.

"We must once again review the existing articles (of the Criminal Code of Ukraine, - ed.), if it is necessary to make amendments as regards treason, introduce a definition of collaboration and who the collaborators are," Chubarov said.

The head of the Mejlis also suggested that the Crimeans, who participated in the establishment of Russian power in Crimea, will leave the peninsula before the departure of Russian troops.

Annex 102

RIA Novosti Crimea, *The Head of the Mejlis named the condition for the resumption of water supply to Crimea* (30 June 2019)

(translation)

Translation

RIA Novosti Crimea, *The Head of the Mejlis named the condition for the resumption of water supply to Crimea* (30 June 2019), available at: <https://crimea.ria.ru/20190630/1116932081.html>.

The Head of the Mejlis* named the condition for the resumption of water supply to Crimea



10:23 30.06.2019

© RIA Novosti. Konstantin Chalabov

SIMFEROPOL, June 30 - RIA Novosti Crimea. The leader of the extremist organisation Mejlis of the Crimean Tatar People, which is banned in Russia*, Refat Chubarov said that resumption of water supply to Crimea via the North Crimean Canal is possible only if the peninsula returns to Ukraine.

"There is only one condition: a specific plan for the de-occupation of Crimea on the table, when we see the stages, dates, a chronicle of the withdrawal of Russian troops. Only direct negotiations about it. Water - after de-occupation or at the moment of de-occupation at least," Chubarov said in an interview with Ukrainian media.

At the same time, he stressed that the water blockade of the peninsula leads not only to complications in the lives of Crimeans, but also worsens the environmental situation on the peninsula.

"We have done everything to make Crimea as expensive as possible to maintain (by Russia - ed.). The events of recent years show what enormous resources Russia invests in the maintenance of the peninsula... We realise that further refusal of water supplies

does not just make life more difficult for the occupants, but also has an impact on the ecological situation," Chubarov stressed.

Until 2014, Ukraine provided up to 85% of Crimea's fresh water needs through the North Crimean Canal. It was used to irrigate about 140,000 hectares of agricultural land. After the reunification of the peninsula with Russia, the water supply through the canal was completely stopped. A number of projects were implemented to supply water to consumers in Crimea. For example, in 2014, hydraulic engineering structures were built to fill the North Crimean Canal with water from the Belogorskiy and Taigan reservoirs along the Biyuk-Karasu River. Thanks to this engineering solution, the residents of eastern Crimea began to receive water. In addition, in October 2014 the construction of three water intakes in Nizhnegorsk and Dzhankoy districts - Novogrigoryevsky, Nezhynsky and Prostornensky began with a total flow rate of about 200 thousand cubic meters per day. The project includes drilling of 12 artesian wells with depth from 110 to 180 meters on each of the water intakes. The total cost of works is about 1.2 billion rubles. The construction of the water intakes was completed in autumn 2016.

Crimea became a Russian region after the 2014 referendum, in which an overwhelming majority of voters in the Republic of Crimea and Sevastopol voted in favor of reunification with the Russian Federation. Moscow has repeatedly stated that the residents of the peninsula made their choice in favor of Russia democratically, in full compliance with international law and the UN Charter. According to Vladimir Putin, the issue of Crimea is "closed for good".

** Extremist organization banned in Russia*

Annex 103

RIA Novosti Crimea, *“Right Sector” reported that “Azov” had joined the blockade of Crimea (1 October 2015)*

(translation)

Translation

RIA Novosti Crimea, *"Right Sector" reported that "Azov" had joined the blockade of Crimea (1 October 2015)*, available at: <https://crimea.ria.ru/20151001/1101141850.html>.

"Right Sector" reported that "Azov" had joined the blockade of Crimea



15:40 01.10.2015

© RIA Novosti . Alexander Maksimenko

According to the "Right Sector", members of the "Azov" battalion are setting up their tents at the "Chongar" checkpoint. The "Azov" fighters will also stand at the "Chaplynka" and "Kalanchak" checkpoints.

KIEV, Oct. 1 - RIA Novosti (Crimea). The press service of the extremist "Right Sector" said on Thursday that fighters of the "Azov" battalion had joined the goods blockade of Crimea.

On September 20, activists of the extremist movement "Right Sector", banned in Russia, and other Ukrainian organizations at the initiative of members of the Verkhovna Rada of Ukraine Refat Chubarov and Mustafa Dzhemilev blocked the delivery of goods to Crimea. The Kiev authorities are not preventing the blockade of the peninsula. The authorities of the Russian republic consider the action pointless.

"The blockade of Crimea was joined by "Azov" fighters, who right now are setting up their tents at the "Chongar" checkpoint. According to the commander of the group of newcomers, ... in the future "Azov" will also stand at the checkpoints "Chaplynka" and "Kalanchak", the press service said.

Crimea became a Russian region after the March 2014 referendum in which the overwhelming majority of residents of the Ukrainian autonomy at the time, who did not recognise the legitimacy of the coup d'etat in Ukraine, voted in favor of joining the Russian Federation. Moscow stressed that the holding of the referendum in Crimea complies with international law and the UN Charter. Ukraine still considers Crimea its own, but temporarily occupied territory.

"Right Sector" is a Ukrainian association of radical nationalist organisations. In January and February 2014, "Right Sector" fighters participated in clashes with police and seizures of administrative buildings, and in April, they were involved in suppressing protests in eastern Ukraine. In November 2014, the Russian Supreme Court declared the right-wing radical association an extremist organisation and banned its activities in Russia.

The "Azov" Volunteer Battalion takes an active part in operations in southeastern Ukraine. The military operation against the disgruntled residents of Donbass has been going on for more than a year. "Azov" is a part of the National Guard of Ukraine.

Annex 104

Komsomolskaya Pravda, "*Immortal Regiment 2018*" in Crimea: *Route and Time* (3 May 2018)

(translation)

Translation

Komsomolskaya Pravda, “Immortal Regiment 2018” in Crimea: Route and Time (3 May 2018), available at: <https://www.crimea.kp.ru/daily/26825.4/3863926/>.

SOCIETY, 3 May 2018 at 01:23 PM

“Immortal Regiment 2018” in Crimea: Route and Time

Komsomolskaya Pravda found out where the “Immortal Regiment” columns will pass on the 9th of May

By Anastasia Kurdyukova



Thousands of people will walk through the central streets with portraits of their grandfathers and great-grandfathers. Photo: Dmitry METELKIN

On the 9th of May, the Crimea will host festive events dedicated to the 73rd anniversary of the Victory in the Great Patriotic War. The most important event, in addition to the military parades that will be held in three cities on the peninsula, will be the patriotic action called “Immortal Regiment”. Thousands of people will walk through the central streets with portraits of their grandfathers and great-grandfathers. Adults and children will participate in the action, with people standing in a column with portraits of heroes, flowers, St. George ribbons, balloons and other symbols of the holiday.

The arrangers ask the participants not to take Russian flags and copies of battle banners so as not to block the portraits. The use of any political, corporate or national symbols or slogans is also prohibited.

“Anyone wishing to demonstrate portraits of any political figures, symbols on clothes, badges,

flags or banners will be removed from the column”, the arrangers warn. “We also ask you not to enter the column with portraits of those people who are not your relatives, even if they are famous military commanders of the Great Patriotic War”.

IMPORTANT INFORMATION

To enter in the “Immortal Regiment” column, you may take an ordinary photo or a specially made stander, which is an enlarged, scanned photo fixed on plastic, laminated and attached to a holder. You can order it in a workshop or make at home by yourself.

On the main part of the stander there should be a photo of the hero, with his or her surname, name, patronymic and rank in the lower one.

If you prepare the stander by yourself, a regular file or lamination will help protect the portrait from moisture. The handle can be made as an ordinary wooden stick 1.2 to 1.3 metres long. You can use self-tapping screws and a moisture-resistant superglue to fix it to the photo frame and the cardboard or plastic, respectively.

SIMFEROPOL

Gathering time and place: at 08:45 AM on Sevastopolskaya Street, the Crimean Council of Ministers (the intersection of Chekhov and Kozlova Streets).

Beginning of the procession: at 11:00 AM.

Movement route: Chekhov Street – Kirov Street – Karl Marx Street – Pavlenko Street – Gagarin Park, Eternal Flame

Inquiries at +7(978) 729 87 38

YEVATORIA

Gathering time and place: at 08:30 AM near the Eternal Flame on Lenin Avenue

Beginning of the procession: at 09:00 AM.

Movement route: along Lenin Avenue

Inquiries at +7 (978) 715-04-37

YALTA

Gathering time and place: at 01:30 PM on the bridge near Oreanda Hotel

Beginning of the procession: at 02:00 PM.

Movement route: along the embankment from Oreanda Hotel to the Lenin monument

Inquiries at +7 (978) 776-53-80

ALUSHTA

Gathering time and place: at 09:30 AM on Sovetskaya Square

Beginning of the procession: at 10:00 AM.

Movement route: along Lenin Street from Sovetskaya Square to the seaport

Inquiries at +7 (978) 739-51-10

KERCH

Gathering time and place: from 07:00 AM to 09:00 AM in the seaport and from 09:00 AM to 11:00 AM on Karl Marx Street

Beginning of the procession: at 11:00 AM.

Movement route: intersection of Kirov and Karl Marx Streets – Lenin Square – Glory Square – Mount Mithridat

Inquiries at +7 (978) 705-72-96

SUDAK

Gathering time and place: at 09:00 AM on Lenin Street and in the town garden.

Beginning of the procession: at 10:00 AM.

Movement route: from Lenin Street to the Hill of Glory, then a rally, climbing the hill and laying flowers at the obelisk

Inquiries at +7 (978) 707-33-27

DZHANKOY

Gathering time and place: from 09:00 AM to 10:00 AM at 5 Lenin Street.

Beginning of the procession: at 10:00 AM.

Movement route: Lenin Street – Internatsionalnaya Street – town park (up to the Monument to the Internationalist Soldiers).

Inquiries at +7 (978) 874-37-50

SEVASTOPOL

Gathering time and place: at 10:00 AM on Lenin Street near the Monument to Komsomol Members.

Beginning of the procession: at 11:00 AM (depends on how quickly the procession of servicemen and military vehicles will pass).

Movement route: Lenin Street – Nakhimov Square – Lazarev Square

Inquiries at +7 (978) 019-20-80

Annex 105

KP.ua, *Rally in Memory of Deportation Victims Took Place in Crimea* (18 May 2013)

(translation)

Translation

КР.ua, *Rally in Memory of Deportation Victims Took Place in Crimea (18 May 2013)*, available at: <https://kp.ua/crimea/394378-v-krymu-proshel-mytynh-pamiaty-zhertv-deportatsyy>.

Rally in Memory of Deportation Victims Took Place in Crimea

By Kyrill Kozlov (*Komsomolskaya Pravda, Crimea*)

18 May 2013 at 03:59 PM



Photo: The car traffic was blocked during the rally. Photo: *qha.com.ua*

Mourning rallies in memory of the deportation of the Crimean Tatar people are held annually. Today, about 25,000 people came to Lenin Square, holding banners with slogans “Give the status of an indigenous people to the Crimean Tatars!” and “We are on our land”.



According to rough estimates, about 25,000 people came out to rally on Lenin Square.

As the participants of the rally marched in columns from different parts of the city, the car traffic was blocked. Responsible police guards had to beef up security these days to maintain the order. According to law enforcement officers, no incidents were reported during the rally.

Annex 106

Avdet, So that the youth remember (26 February 2000)

(translation)

Translation

Avdet, *So that the youth remember* (26 February 2000), available at:
<https://avdet.org/2000/02/26/strong-CHtoby-pomnila-molodezh-Gulnara-Abdulaeva-Zazhi-ogonek-v-svoem-serdtse-pod-takim-lozungom-17-maya-Krymskotatarskij-Molodezhnyj-TSentr-KMTS-minuya-prepony-i-nedovolstva-so-storony-vlastej/>.

So that the youth remember

26.02.2000 00:00

So that the youth remember

[Gulnara Abdulaeva]

"Light a fire in your heart" - that was the slogan under which the Crimean Tatar Youth Centre (CTYC), bypassing obstacles and discontent from the authorities, held one of its actions on Lenin Square in Simferopol on 17 May. 2,100 candles, one by one, were lit in the evening on the central square of the city. To the enchanting voices of Oksana Ametova, Emilia Ablaeva and Elnara Kuchuk, the outlines of the Crimean Peninsula with the number "63" inside were put aflame, 63 marking the anniversary of the deportation of the Crimean Tatar people. Candles were also lit in the form of a flag with Crimean Tatar insignia, tarak tamga, under which the inscription "No discrimination" was lit in English.

The Crimean authorities initially disliked the patriotic mourning event. In response to the request to hold the event, the organizers of the CTYC were refused to hold the action on Lenin Square. However, the authorities offered the less popular Shevchenko Park instead, but the guys refused on the grounds that this place would not be suitable at all for the event. On 15 May Eskender Bariyev, honorary chairman of the CTYC, held a press conference on the rejection, at which he said that it was not clear why the city authorities proposed to hold the rally in Shevchenko Park. "This is a park area", he said, "and besides, there is little asphalt surface there. However, Lenin Square is the square where various events are held, so we thought we had the right to hold the rally there".

At the press conference, he also said that the Crimean Tatar youth intended to insist that they be allowed to hold the "Light a fire in your heart" event in the originally planned place - the central square of Simferopol.

Eventually, after much friction, the CTYC and the city authorities reached an agreement that the action will be held on Lenin Square, but the authorities recommended that it begin at 8 p.m. instead of an hour later, as previously planned, so as not to disturb the peace of the city.

In his statement, the honorary head of the CTYC stressed that the action "Light a fire in your heart" was not political, and there would be no rally or any political statements during it. Eskender Bariyev also expressed hope that not only Crimean Tatars but also representatives of other nationalities would come to light candles, including those who were not affected by the deportation.

On 17 May, at 8 p.m. sharp, more than 500 people, mostly young people, came to commemorate the victims of the deportation. Eskender Bariyev, the honorary chairman of the CTYC, opened the event with an opening speech. Then participants started lighting small candles in the shape of a map of the Crimean Peninsula, with the number "63" inside, and next to the outline of the peninsula a Crimean Tatar flag with the inscription "No discrimination" underneath. Oksana Ametova, Emilia Ablaeva and Elnara Kuchuk, Crimean Tatar artists invited to the mourning event, performed patriotic songs during which lighters and matches were passed by a human chain to all those who were not indifferent to the tragedy of the Crimean Tatar people that happened in the early morning of May 18, 1944. There is not a single Crimean Tatar who hasn't been affected by this terrible tragedy, death knocked on almost every family's door and we must

always remember it. Perhaps the mourning event "Light a fire in your heart" will become a tradition established by the Crimean Tatar Youth Centre.

Annex 107

Mejlis, *Over 40,000 people took part in All-Crimean mourning rally dedicated to the 69th anniversary of the deportation of Crimean Tatars* (18 May 2013)

(translation)

Translation

Mejlis, Over 40,000 people took part in All-Crimean mourning rally dedicated to the 69th anniversary of the deportation of Crimean Tatars (18 May 2013), available at: <https://web.archive.org/web/20140324063144/http://qtm.org/новости/2873-свыше-40-тысяч-человек-приняли-участие-во-всекрымском-траурном-митинге-посвященном-69-й-годовщине-депортации-крымских-татар>.

Over 40,000 people took part in All-Crimean mourning rally dedicated to the 69th anniversary of the deportation of Crimean Tatars

News

On 18 May 2013, more than 40 thousand people participated in the All-Crimean memorial meeting dedicated to the 69th anniversary of the deportation of the Crimean Tatar people from their historical native land - Crimea.

In all settlements of Crimea, Kherson and Zaporozhye regions, where a considerable number of Crimean Tatars live, local mourning meetings were held starting on the morning of 18 May 2013, and prayers for the victims of deportation and decades of forcible confinement in places of exile were performed.



In addition, prayer services for the victims of the genocide of the Crimean Tatar people were held at the Ukrainian embassies in European capitals: Brussels, The Hague, Berlin, Vienna, Paris, Warsaw, Bern and other capitals of EU member states, as well as in Turkey - in Ankara and Istanbul.



In the morning, flowers were laid at the foot of memorial signs and monuments, prayers read and mourning rallies held.



Five columns of the participants of the rally marched from the train station, Salgirka park, Zapadnaya bus station, Victory Avenue and Zhukova microdistrict along Ak'mesjit streets to the central square.





During the lunchtime namaz, representatives of the Spiritual Administration of Muslims of Crimea recited an ezan, a call to perform namaz.



At 12.00 local time the international action "The Minute of Sorrow and Unity" was held. The participants, regardless of their location, stopped for a few minutes, bowed their heads and prayed in memory of those who have not returned and thanked the Almighty for the fact that today we are all together on our land.



On this day, during the "Minute of Sorrow and Unity", participants of We-Europeans movement in Kiev, more than 50 participants of the international conference "Civil Society in Ukraine" arriving from all regions of Ukraine to Crimea, as well as many other friends of Crimean Tatar people, were united and felt solidarity with Crimean Tatars.

The All-Crimean memorial meeting in memory of the victims of genocide of the Crimean Tatar people – the deportation of 18 May 1944 and the decades of their forced stay in the places of exile - was opened by Refat Chubarov, First Deputy Chairman of the Mejlis of the Crimean Tatar people, President of the World Congress of the Crimean Tatars.



In the central square of Ak'mesjit, participants of the All-Crimean mourning rally held national Crimean Tatar flags, Ukrainian state flags, and banners with inscriptions "Mogilev! Leave Crimea and take with you the team of the Council of Akjakals 2", "We are on our land!", "Give the Crimean Tatars the status of an indigenous people!", "Extend the Bishkek agreements!", "With a chauvinistic snout - no way to the European Union!", "Eternal memory to the victims of the genocide of the Crimean Tatar people" and others.



After the performance of the national anthem of Ukraine and the Crimean Tatar national anthem, the Muslim Mufti of Crimea Haji Emirali Ablaev said a prayer in the memory of the victims of the deportation and decades of forced detention in the places of exile. Then the head of the Verkhovnaya Rada Committee on Human Rights, National Minorities and Interethnic Relations Valery Patskan addressed the participants of the All-Crimean mourning rally.



"The terrible crime committed against an entire people runs counter to universal principles of humanism and respect for human rights," Patskan emphasized. – "We believe that it is unfair that the political, legal and socio-economic problems of the FDPs remain unresolved. We recognize the need to resolve these issues, to restore justice to the Crimean Tatar people, your rights and your opportunity to live in your native land enjoying full rights. It requires effective steps from the Ukrainian and Crimean authorities."

Valery Patskan assured the participants of the All-Crimean mourning meeting that the Committee in the Verkhovna Rada of Ukraine headed by him will do its best to adopt the Law on the restoration of the rights of the citizens deported on the ethnicity grounds. The Head of the Committee is also convinced that no less important in the solution of the problems of return, accommodation and renewal of the rights of Crimean Tatar people is the convergence of the positions of the state authorities and traditional elective national institutions of the Crimean Tatar people – the Qurultay and the Mejlis.

The words of grief on the day of mourning and their support for the Crimean Tatar people were said by:



Chairman of the Democratic Union of Turkic Tatar Muslims of Romania Jelil Eserjep,



Amet Varol, a member of the Executive Committee of the World Congress of the Crimean Tatars



Murtaza Essencal, head of the Turkish Foundation "CRIMEA" in Ankara,



Deniz Shahin, Secretary General of the Crimean Tatar Culture and Mutual Aid Society of Ankara



Chairman of the Congress of National Communities of Ukraine, Soviet dissident Joseph Zissels



Aisha Seytmuratova, a veteran of the Crimean Tatar national movement and a Soviet prisoner



Alexander Mochkov, a Ukrainian MP from the Udar party.

On 18 May 2013, Eduard Leonov, an MP of the All-Ukrainian Union of Freedom, also spoke at the All-Crimean mourning rally.

"I send you my sincere congratulations, dear Crimean Tatars, for preserving your national dignity, defending your right to self-determination, defending your right to the future of your children and grandchildren," the Ukrainian MP stressed. "The All-Ukrainian Freedom Association will do its best to give your people, people who have been suffering for so long, the right to self-determination within the borders of one powerful unitary state of Ukraine, because for many centuries we have fought side by side for our independence against various occupants, we have common history and we will find how to restore order on our God-given land and we do not need occupants here."



The Ukrainian politician, who represents the Svoboda (Freedom) party in the Ukrainian parliament, also said that the Mejlis of the Crimean Tatar people should become a local self-government body and the Crimean Tatar people should receive the necessary quotas in all representative and executive government bodies.

"You and we are the owners of this God-given land, and only you and we, Crimean Tatars and Ukrainians, can determine how we should live and how we should bring up our children and how we should govern the state," Eduard Leonov stressed.

Deputy Chairman of the Council of the Autonomous Republic of Crimea (ARC) Aziz Abdullaev, Regional Representative of the UN High Commissioner for Refugees in Belarus, Moldova and Ukraine Aldrich Andrysek, Consul General of Germany in ARC Igor Ogorodnik, Political Advisor of Czech Embassy in Ukraine Lubosh Veselu, numerous Crimean Tatars from Romania, Turkey, community from Russia, and representatives of different political and social forces of Ukraine also participated in the All Crimea memorial rally.

In his annual speech at the All-Crimean mourning meeting in memory of the victims of genocide of Crimean Tatar people – the deportation on May 18, 1944 and decades of their forcible detention in the places of exile, the Chairman of Mejlis of the Crimean Tatar people Mustafa Jemilev, addressing the participants of the mourning meeting, summarized the results of the year 2012 and talked about the most important upcoming events concerning the future of the Crimean Tatar people.

The Chairman of Mejlis underlined that at all times when the authorities impeded the restoration of the national rights of the Crimean Tatars, they resorted to the methods aimed at splitting the people, creating and stimulating different groupings and political trends, the main task of which was to create the hostile environment among the compatriots and thus if not to suppress the national movement, at least to weaken this movement and make it less efficient.



"This has been the case since the first days of Russia's conquest of Crimea, in Soviet times, and unfortunately it has been the case, especially during the last three years, also in the years of Ukraine's independence," Dzhemilev noted. – "Since the proclamation of Ukraine's independence, except for the short period of Meshkov's 'presidency' in 1994-95, never has such a frankly chauvinistic, provocative and very short-sighted policy towards the Crimean Tatars been conducted in Crimea. We know how the career of 'President' Meshkov ended, he found refuge with his masters in Moscow. There is no doubt that the same thing awaits Anatoly Mogilev, the head of the CM of the ARC. But every day of his stay in power in Crimea is an irreparable damage to the interests and prestige of the country, a threat to interethnic harmony and stability in Crimea."

The leader of the Mejlis of the Crimean Tatar people Mustafa Dzhemilev said he demanded the immediate resignation of the head of the Crimean government, A. Mogilev and the investigation by prosecutors into his provocative chauvinistic activities, reinstatement of all those fired on political and nationalist grounds, compensation for the moral and material damage they have suffered.





"Our demands today, in these hours by our diaspora will also be handed over to Ukrainian embassies in many European countries, to the offices of the European Union and the European Parliament," added the head of the Mejlis, people's deputy of Ukraine M. Dzhemilev. At the end of the All-Crimean memorial meeting, the head of the Mejlis secretariat Zair Smedlyaev read the draft Resolution of the All-Crimean memorial meeting for the victims of the genocide of the Crimean Tatar people - the deportation of 18 May 1944 and the decades of their forcible detention in the places of exile to the participants of the meeting.



On 18 May 2013, over 40 thousand participants of the All-Crimean mourning rally unanimously adopted the Resolution.

Annex 108

Milli Firka, *Mejlismen want Mogilev's resignation* (7 May 2013)

(translation)

Translation

Milli Firka, *Mejlismen want Mogilev's resignation (7 May 2013)*, available at: <http://milli-firka.org/меджлисмены-хотят-отставки-могилева/>.

Mejlismen want Mogilev's resignation

07.05.2013

Mejlismen want Mogilev's resignation

A briefing for journalists was held in Simferopol on 4 May 2013 following a closed meeting between members of the Mejlis and representatives of Crimean Tatar organizations and associations from Turkey and several other countries.

The briefing, along with Mustafa Dzhemilev, head of the Mejlis, was attended by Chairman of the Istanbul branch of the Society of Culture and Mutual Assistance of Crimean Tatars in Turkey Dzhelyal İçten, Mejlis representative in Turkey Zafer Karatay, Head of Crimean Tatar Culture and Mutual Assistance Society of Eskisehir Mesut Or and representative of Crimean Tatar Culture and Mutual Assistance Society of Kocaeli (Turkey) Zumran Araci. This was reported by the website of the Milli Mejlis.



The head of the Mejlis revealed the theses of the draft resolution, which Mejlis intends to announce at its rally on 18 May, on the Crimean Tatar People's Day of Mourning. One of the main points of the resolution will be a demand for the resignation of the current Crimean prime minister, Anatoliy Mogilev, as well as a demand for the Ukrainian authorities to recognise the Mejlis as a representative body of the people.

"Now Ukraine does not recognise the Qurultay as a body elected by the people and gives full power to the 'Council of Representatives'," the Mejlis head complained to the authorities.

M. Dzhemilyev also said that the Mejlis has always been and remains the defender of Ukraine's independence and territorial integrity and its integration into the European and Euro-Atlantic community.

According to him, the unprecedented pressure, rejection and desire to destroy the Mejlis is the machinations of certain chauvinist forces of the modern Ukrainian authorities.

"All responsibility for this criminal policy and possible complications lies precisely with these forces in Ukraine, led by Crimean Prime Minister A. Mogilev," the Mejlis leader pronounced his verdict on the Ukrainian authorities.

Annex 109

BBC, *Anniversary of deportation: Crimean Tatars want Mogilev's resignation - BBC News Ukraine* (17 May 2013)

(translation)

Translation

BBC, Anniversary of deportation: Crimean Tatars want Mogilev's resignation - BBC News Ukraine (17 May 2013), available at:
https://www.bbc.com/ukrainian/ukraine_in_russian/2013/05/130517_ru_s_crimea_tatars_deportation_anniv.

Anniversary of deportation: Crimean Tatars want Mogilev's resignation - BBC News Ukraine

Enver Abibulla
 Simferopol
 17 May 2013



Caption: Anatoly Mogilev will not attend Tatar rally because he is going on a business trip to Portugal

Mourning events marking the 69th anniversary of the deportation of Crimean Tatars have begun in Crimea. They will end on Saturday with a rally to commemorate those who perished during deportation.

Observers note that it will take place amid a serious deterioration of relations between the autonomy's authorities and the Mejlis, which has already said it will demand the resignation of Crimean Prime Minister Anatoliy Mogilev.

The chairman of the Mejlis, "Fatherland" MP Mustafa Dzhemilev, said in an interview with BBC Ukraine that they had many grievances against Mr. Mogilev.

"The main ones are his 'ethnic cleansing' in staffing: in recent months, more than 20 Crimean Tatars recommended by the Mejlis have been dismissed from leadership positions; then his provocative activities to divide Crimean Tatars, which cause tensions, and of course his public justification of the deportation. Such a xenophobe at the head of the autonomy in a country that wants to become an EU member is absurdity!"- says Mustafa Dzhemilev.

In April he also demanded that the General Prosecutor's Office initiate a criminal case against Mr. Mogilev for what was said to be his involvement in corruption over the land issue.

Mr. Dzhemilev stressed: despite the fact that the Mejlis, after lengthy disputes with the authorities, had assured their right to hold a mourning rally, they are still afraid of provocations, which is why a group of activists will stay overnight on the central square in Simferopol, where the rally will take place on Saturday.

A war of words

The authorities deny all accusations and claim to be actively restoring the rights of deportees. Anatoly Mogilev, prime minister of the autonomy, said in an interview with BBC Ukraine that the Mejlis itself is fuelling the conflict. Mogilev said he guaranteed order at the mourning events.

"Certain leaders of informal national organizations of the Crimean Tatar people are not in the mood for any constructive cooperation with the authorities. Unfortunately, they have chosen the path of artificial conflict aggravation and a broad disinformation campaign in Crimea. The authorities have the strength and dignity to give an adequate assessment to such dirty methods of political struggle," Mr. Mogilev said.

He also accused the Mejlis of embezzling funds allocated for returnees.

"Behind the loud slogans 'for the good of the people' they have been embezzling funds for years that the state appropriated for the settlement of Crimean Tatars. The consequence of this is dozens of criminal cases. In the final analysis, my resignation is called for by those who have been stealing Crimean Tatar money for decades and are afraid that everything hidden will come out," the Crimean prime minister told BBC Ukraine.

Crimean Tatars living better than other Crimeans?

In response, Mejlis chairman Mustafa Dzhemilev called the Crimean prime minister's accusations "bazaar gossip" and said he was likely to take the matter to court to protect his honour. "It is one thing to talk about such things at a bazaar, and another when it is said by a person who knows about the budget allocation system. It is done by government officials. The Mejlis and Dzhemilev have nothing to do with this money," Mr. Dzhemilev said to BBC Ukraine.

The Crimean Tatar leader was also angered by Mr Mogilev's words said on 15 May at a press conference in Kiev - that "the standard of living of Crimean Tatars is, on average, higher than that of other Crimeans."



Caption: The "war" over land in Crimea has been ongoing since the return of Crimean Tatars from deportation.

The chairman of the Crimean government said at the time that for the resettlement of deportees over 20 years, 1.5 billion hryvnias have been allocated from the budget - which, in his opinion, is "a fairly large amount" for 250,000 people. He said that 85,000 plots have been allocated, "which means that each Crimean Tatar family received practically 1.3 plots, while other Crimeans received about 0.6 plots per family."

Mustafa Dzhemilev calls this a "cynical lie" and claims that the majority of Crimean Tatars live in utter poverty.

"During the 23 years after the beginning of mass return of Crimean Tatars, an average of 4,000 hryvnias per one deportee was paid out. That's 12-13 hryvnias a month. This is dozens of times less than the taxes that Crimean Tatars pay. As for land, they counted even those that were bought by Crimean Tatars with their own money," Dzhemilev said.

According to him, almost half of the allocated funds returned to the budget as unappropriated, and Crimean Tatars, unlike other Crimeans, have been excluded for 60 years from the distribution of land resources in Crimea.

"If everything that was taken away from us were returned, there would be no problems. According to very rough estimates, Crimean Tatars' losses from the deportation amounted to \$5 billion. But they claim that they can't even give it back, and they can't allocate normal funds from the budget either. It's a vicious circle," says the chairman of the Mejlis.

Claims of pro-government Crimean Tatars

However, the Mejlis is not in conflict only with the authorities. It has also been criticized by the pro-government politicians in the Crimean Tatar Presidential Council of Representatives. This year, with the help of the autonomy's government, the Rada wanted to seize the initiative to hold the mourning rally. However, after a warning from the Mejlis that the situation could escalate, the organising committee for the preparation of mourning events under the Crimean Council of Ministers agreed that the Day of Remembrance should be held according to the traditional scenario.

The information that opponents of the Mejlis were planning to organise a parallel action turned untrue. Experts remind that last year such an attempt failed - only 150 to 200 people came.



Caption: "Real" rallies on the anniversary of the deportation far outnumber those organised by the authorities.

At the same time, the Council of Representatives accuses the Mejlis of wanting to synchronize the rally in Simferopol with the final part of the all-Ukrainian action of parliamentary opposition "Stand up, Ukraine", which is due to be held on Saturday in Kiev.

After the final decision on the rally had been taken, the Council of Representatives began to criticise Mr Mogilev for weakness. According to media reports, a conflict has arisen between them that may lead to personnel changes in the presidential council.

Despite Anatoliy Mogilev's promises to ensure order at the mourning rally, he will not personally participate in it, for the second year in a row. In 2012, on this day, the prime minister took a sick leave, and this year he leaves for a two-day official visit to Portugal.

Mustafa Dzhemilev has repeatedly urged the Crimean prime minister not to appear at the rally. "No one can guarantee his safety. The Crimean Tatars can throw eggs at him, even if the Mejlis asks them not to, and then they will say that the Mejlis organised it," the head of the Mejlis told the press.

Annex 110

Centre for Investigative Journalism, *Mejlis gives authorities 10 days to demolish Lenin monuments in Crimea - Centre for Investigative Journalism* (23 February 2014)

(translation)

Translation

Centre for Investigative Journalism, Mejlis gives authorities 10 days to demolish Lenin monuments in Crimea - Centre for Investigative Journalism (23 February 2014), available at: <https://investigator.org.ua/en/news/119259/>.

Mejlis gives authorities 10 days to demolish Lenin monuments in Crimea - Centre for Investigative Journalism

23.02.2014



Crimean authorities must rule within 10 days on demolition of Lenin monuments in Crimean cities and districts. This was announced by the head of the Mejlis of the Crimean Tatar people Refat Chubarov during a rally in Simferopol.

"We have a big request to the mayor of Simferopol and the city council. Today we have made maximum efforts to stop the demolition of the Lenin monument. The Simferopol City Council must free the square from the monument within 10 days. We, together with all Crimeans, will choose a name for this beautiful square," Chubarov said.

If the Crimean Tatar demand is not met, he said, active measures will be taken.

"I think the leaders of other cities and districts in Crimea have heard us. If not, we will take action."



The head of the Mejlis addressed the rally: "In 10 days, be ready for a new call. We gave them 10 days. There are 10 thousand of us today, in 10 days there will be 50-60 thousand".

Annex 111

Haberler, *The Organising Committee Has Filed Another Application for the Celebration* (3 June 2015)

(translation)

Translation

Haberler, *The Organising Committee Has Filed Another Application for the Celebration (3 June 2015)*, available at:

<https://web.archive.org/web/20150710141231/http://bayraq.info/haberler/72-orgkomitet-podal-eshche-odno-zayavlenie-na-provedenie-prazdnika.html>.

The Organising Committee Has Filed Another Application for the Celebration

Last time, the Administration of Simferopol / Akmesjit did not give permission to hold the event. On the same day, the Organising Committee decided to file another application for the celebration on the 27th of June in the Fontany microdistrict.

The holiday is the 26th of June, of course. However, there is no need to stick to a specific date. If another Crimean Tatar organisation is going to hold a celebration on the 26th of June and has obtained permission to do so, we decided that we could organise a celebration event on the 27th of June. We hope there will be no grounds for refusal.

Haberler

Annex 112

Gorod 24, *Simferopol Celebrates Taras Shevchenko's Birthday* (10 March 2022)

(translation)

Translation

Gorod 24, Simferopol Celebrates Taras Shevchenko's Birthday (10 March 2022), available at: https://gorod24.online/simferopol/news/238837-v_simferopole_otmetili_den_rojdeniya_tarasa_shevchenko.html.

Simferopol Celebrates Taras Shevchenko's Birthday

Gorod 24: Simferopol

Official website of the Administration of the City of Simferopol

Simferopol Celebrates Taras Shevchenko's Birthday

On 9th of March, commemorative events dedicated to the 208th anniversary of the birthday of the great poet, writer and artist Taras Shevchenko were held in the Crimean capital.

The event was initiated by the Ukrainian Community of Crimea, a regional public organisation, and the House of Peoples' Friendship, a state budgetary institution of the Republic of Crimea, with the support from the State Committee for Interethnic Relations of the Republic of Crimea.

The event was attended by Aider Tippa, Chairman of the State Committee for Interethnic Relations of the Republic of Crimea, Larisa Sokirskaya, Director of House of Peoples' Friendship, Anastasia Gridchina, Chairwoman of Ukrainian Community of Crimea, and Ekaterina Rykova, Head of the Sector for Working with National and Cultural Autonomies of the Department for Interethnic Relations of the Administration of the City of Simferopol.

The attendees laid flowers at the Taras Shevchenko Monument in the Taras Shevchenko Park, paying tribute to the memory of the poet and remembering his role in the history and culture of Ukraine and Russia.

Reference information: *Taras Shevchenko is an outstanding Ukrainian poet and artist. His works were written in Ukrainian and Russian. His legacy is considered to have laid a foundation for the modern Ukrainian language. He was a man of universal talents and interests. His works have been translated into almost all the languages of the world, and many of his works have been set to music by Mykola Lysenko and other composers.*

Annex 113

Millet, Khizmet ve Bereket, TV Programme of 18 November 2022, Ayder Ismailov
(18 November 2022)

(translation)

Translation

Millet, *Khizmet ve Bereket*, TV Programme of 18 November 2022, Ayder Ismailov (18 November 2022), available at: <https://trkmillet.ru/program-episode/khizmet-ve-bereket-vipusk-ot-18-11-22-ayder/>.

MILLET

***Khizmet ve Bereket*, TV Programme of 18 November 2022, Ayder Ismailov**

18 November 2022 at 08:30 PM

0:00 / 28:28



The guest of our today's *Khizmet ve Bereket* TV programme is Ayder Ismailov, the Deputy Mufti of Crimea and Sevastopol, who will tell us about his duties.

Project: *Khizmet ve Bereket*

Annex 114

Millet, Prime Time. TV Programme of 24 November 2022, Eldar Seitbekirov
(25 November 2022)

(translation)

Translation

Millet, Prime Time. TV Programme of 24 November 2022, Eldar Seitbekirov (25 November 2022), available at: <https://trkmillet.ru/program-episode/praym-taym-vipusk-ot-24-11-22-yeldar-seitbek/>.

MILLET

Prime Time. TV Programme of 24 November 2022, Eldar Seitbekirov

25 November 2022 at 02:27 PM

0:00 / 13:47

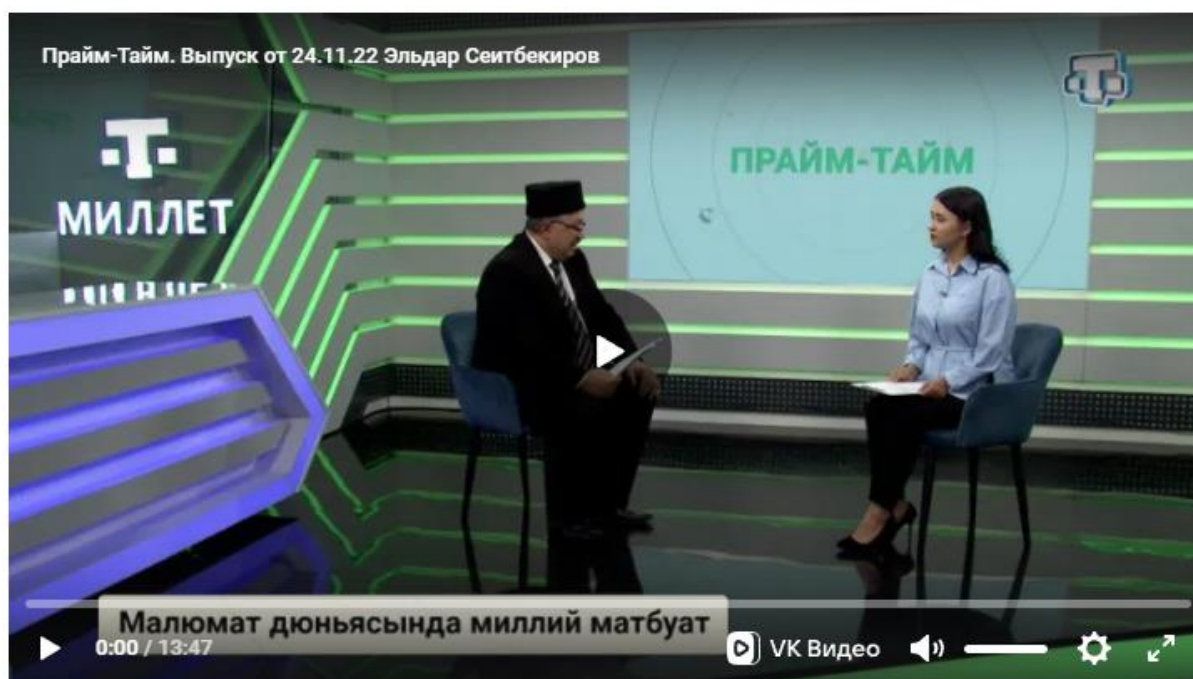

The World Information Day is celebrated on the 26th of November. How does the national press find its place in the media world? We are discussing it with Eldar Seitbekirov, the editor-in-chief of *The Golos Kryma* [Voice of Crimea] newspaper.

Project: Prime Time

Annex 115

Millet, *Ana Yurtun – Altyn Beshik*, Episode 28, Remzi Devletov (21 November 2022)

(translation)

Translation

Millet, *Ana Yurtun – Altyn Beshik*, Episode 28, Remzi Devletov (21 November 2022), available at: <https://trkmillet.ru/program-episode/ana-yurtun-altin-beshik-28-vipusk-rem/>.

MILLET

Ana Yurtun – Altyn Beshik, Episode 28, Remzi Devletov

21 November 2022 at 02:24 PM

0:00 / 5:34

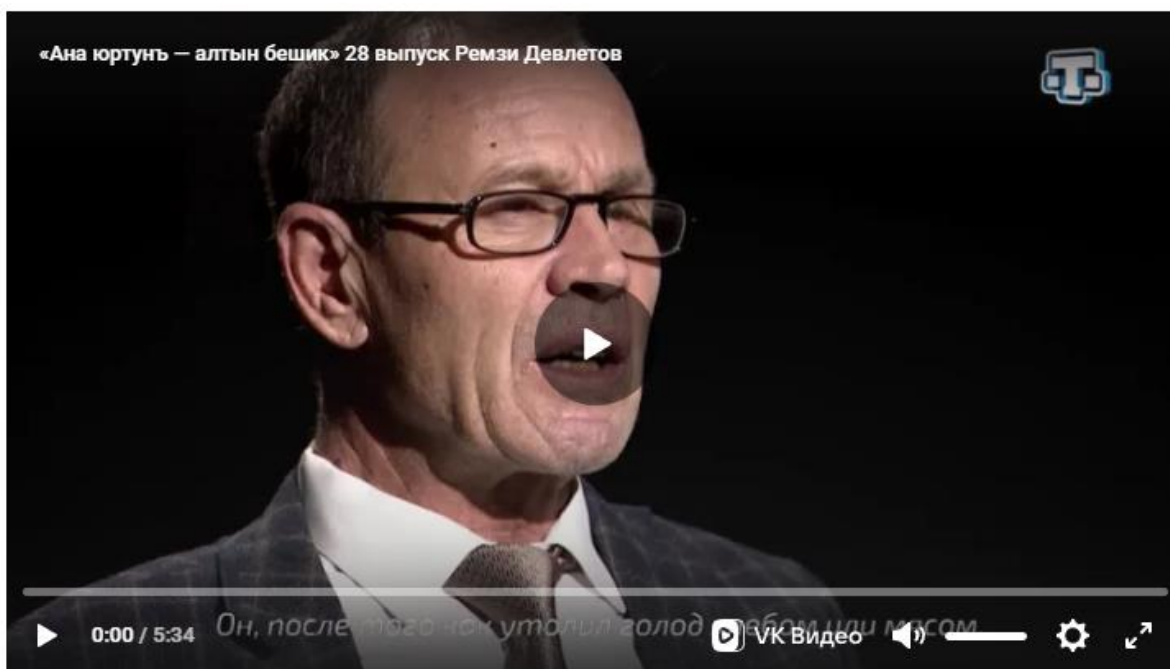

The guest of our TV studio is Remzi Devletov, the head of Literature and Dramaturgy at the Crimean Tatar Academic Theatre, who will talk about the importance of arts for society in general and for the life of every man and woman in particular.

Project: *Ana Yurtun – Altyn Beshik*

Annex 116

Millet, *Tek arzum Watan!*, *TV Programme of 17 November 2022*, *Eskender Tarakchiev* (21 November)

(translation)

Translation

Millet, *Tek arzum Watan!*, TV Programme of 17 November 2022, Eskender Tarakchiev (21 November), available at: <https://trkmillet.ru/program-episode/tek-arzum-vatan-vipusk-ot-17-11-2022-yeskende/>.

MILLET

***Tek arzum Watan!*, TV Programme of 17 November 2022, Eskender Tarakchiev**

21 November 2022 at 11:51 AM

0:00 / 1:01:02



A hardworking person is never idle. The guest of our *Tek arzum Watan!* programme is Eskender Tarakchiev, a member of the Nizhnegorsk District Council, who talks about his activities, service to the Homeland and the people.

Project: *Tek arzum Watan!*

Annex 117

Millet, Prime Time. TV Programme of 22 September 2022. Ruslan Yakubov (23 September 2022)

(translation)

Translation

Millet, Prime Time. TV Programme of 22 September 2022. Ruslan Yakubov (23 September 2022), available at: <https://trkmillet.ru/program-episode/praym-taym-vipusk-ot-22-09-2022-ruslan-yakubov/>.

MILLET

Prime Time. TV Programme of 22 September 2022. Ruslan Yakubov

23 September 2022 at 11:11 AM

0:00 / 8:00

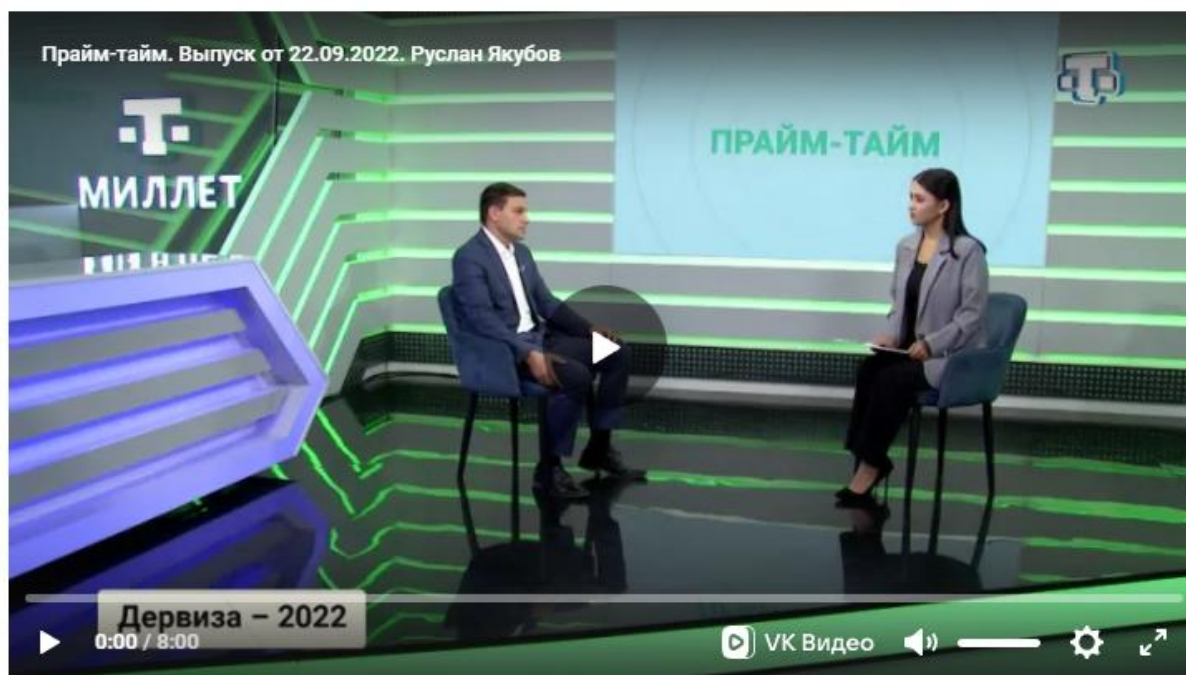

Project: Prime Time

Annex 118

Crimea Newsfeed, *Third Open Festival-Contest of Children's Folklore Groups 'Crimean Terem'*
held in Crimea (3 December 2018)

(translation)

Translation

Crimea Newsfeed, *Third Open Festival-Contest of Children's Folklore Groups 'Crimean Terem' held in Crimea* (3 December 2018), available at: <https://crimea-news.com/society/2018/12/03/465715.html>.

Third Open Festival-Contest of Children's Folklore Groups 'Crimean Terem' held in Crimea

03.12.2018, 19:11 Society



From 30 November 30 to 2 December 2018, the Third Open festival-contest of children's folklore groups 'Crimean Terem' was held in Simferopol, as reported by the press service of the Ministry of Education, Science and Youth of the Republic of Crimea.

According to the press service, the festival-competition brought together over 450 performers - children and youth folklore vocal, choreographic and instrumental groups, soloists from 9 regions of the Republic of Crimea and Russia: Krasnogvardeysky District, city of Simferopol and Simferopol District, Dzhankoy and Dzhankoy District, cities of Feodosia, Alushta, Evpatoria, and Penza.

"The work of the jury was headed by the artistic director of the Vocal and Choreographic Ensemble 'Tavria' of the Crimean State Philharmonic, the Honored Artist of Ukraine and the Republic of Crimea I.N.Mikhaylevsky. Competition programmes included works of different genres: music and song, dance, play and oral folklore, instrumental music, fragments of folk festivals, rituals," - said the press service.

According to results, the first-degree laureates among ensembles were: Folk Dance Ensemble "Ulybka" (junior group), Alushta Centre for Children's Creativity (director N. Lindegrin) with compositions "Hutsul dance" and "Belarusian danc"; Ensemble of Folk Song "Sudarushka", Simferopol School of Arts (director Andreichenko, concert master A. Morgunov). The program of the ensemble included songs "Dubravushka", wedding majestic song of the Don Cossacks,

and “On the Mountain, the Roosters Sing”, a kupala song of Voronezh region; Folk ensemble “Svetlitsa” (junior group) from Simferopol, SEBEK “Art School” (director E.S. Mirgorodskaya, concertmaster D.A. Benko) with folk-ethnographic composition “Baiki-pobaiki” based on motherhood folklore materials; Exemplary folk dance group “Dance-College”, Rodnikovskiy Village house of culture, Simferopol district (director L.I. Nakonechnaya), with folk songs “Trails” and “Greek Dance”; Folklore ensemble “Svetlitsa”, Simferopol School of Arts (director I.L. Mikhaylevskaya, concert masters D.A. Benko, E.V. Uvarov), with spiritual verse of the Russian Poozeria “How the Red Sun Came Up” and “Voice Roll Up” (Studenovskie Stradania) (Lipetsk region); Folk dance ensemble “Ulybka” (junior group) from Children's Art Centre of Alushta (director N.F.Lindegrin) with compositions “Dymkovo Toy” and “Vasya-Vasilek”.

Source: <https://kianews24.ru>

City: Alushta, Dzhankoy, Yevpatoria, Simferopol, Feodosia

Annex 119

Kerch Education and Training Complex Boarding School-Lyceum of Arts, "*Pearl of Crimea*"
Dance Ensemble – Winner of the Republican Contest "Crimean Terem" (6 December 2019)

(translation)

Translation

Kerch Education and Training Complex Boarding School-Lyceum of Arts, “*Pearl of Crimea*” Dance Ensemble – Winner of the Republican Contest “Crimean Terem” (6 December 2019), available at: http://licey-iskusstv.ru/news/ansambl_tanca_zhemchuzhina_kryma_pobeditel_respublikanskogo_konkursa_krymskij_terem/2019-12-06-1123.

“Pearl of Crimea” Dance Ensemble – Winner of the Republican Contest “Crimean Terem” - 6 December 2019



On 5 December 5 at 14.00, the State Academic Musical Drama Theatre of Simferopol hosted a gala concert and the award ceremony for the winners of the Open Festival-Contest of children's folklore groups "Crimean Terem".

The Festival was founded by the Ministry of Education, Science and Youth of the Republic of Crimea. The goal of the festival is esthetic, moral and spiritual education of the younger generation on the best examples of folk art, preservation and continuity of performance traditions, development of national cultures, identification and support of original art groups and solo performers. This year, 93 applications to participate in the festival were satisfied, over 700 young disciples of folk traditions aged 6 to 18, from all parts of Crimea, presented their numbers to the jurors.



The Exemplary folk-dance ensemble “Pearl of Crimea” from the Art Lyceum became a participant of the festival for the first time. The middle group of the collective took part in the nomination ‘Choreographic art’.

Dance is the oldest kind of art: interesting, multi-faceted, bright, with an enormous emotional charge. Long ago folk dance began the originator of all trends that formed during the ages on its basis: classical dance, historical folk dance, stage dance and contemporary dance. Fashion and time have not been able to make folk dance disappear from our life and from the history of nations. Up to this day, each society cherishes the memory of previous generations and takes care of all that constituted their life. That is why dance is an invaluable treasure that retains everyday life and traditions of nationalities. Taking all that into account, the collective was correspondingly prepared for the contest by the teachers of the Choreography Department of the Lyceum: T.V. Mamykina, A.I. Tikhonenko, E.N. Antonova and the director of the Ensemble, Honored Worker of Culture of the Republic of Ukraine, Merited Worker of Education of Ukraine Vera Alexandrovna Ivanova.



Our group successfully performed two dance numbers as competition entries: a merry Russian dance “Pritopy” and a fiery Ukrainian dance “Vesvolka”.

At the Gala concert, the group performed Vesvolka among other winners.

Our congratulations to the students and teachers!

Annex 120

Krym Reali, *Ukrainian and European dances performed in Sevastopol (+video)*
(24 March 2018)

(translation)

Translation

Krym Realii, *Ukrainian and European dances performed in Sevastopol (+video)* (24 March 2018), available at: <https://ru.krymr.com/a/news/29121649.html>.



NEWS

Ukrainian and European dances performed in Sevastopol (+video)

24 March 2018, 22:43

The 23rd citywide dance festival kicked off in Sevastopol on 24 March in which took part choreographic ensembles from the annexed Crimea.

It was reported by a correspondent of Krym.Realii.

The event was held at the Palace of Culture "Sevastopolsky" in the suburban Sakharnaya Golovka village. It was organised by the administration of the palace of culture as well as the administration of Russian Balaklava municipality of Sevastopol.

On the first day of the festival, Russian, Ukrainian and Moldovan folk dances, as well as classical European, Chinese and Kazakh dances were performed.



The folk dance ensemble "Sudarushka" performed the "Ukrainian Round Dance" in modern interpretation; the folk ensemble "Sevastopol" performed "Hutsul dance". The ensemble "Crimean pearls" from Saki performed dance composition "Calling for Spring" based on Ukrainian folk motifs.

At the end of the first day of the festival the organisers awarded the ensembles performing folk and classical dances with Certificates of Appreciation.

On Sunday, 25 March, stage (variety) dances will be shown at Sevastopolsky cultural centre.

Annex 121

Avdet, Crimean Tatars cherish their language so much that they don't even speak it
(24 June 2013)

(translation)

Translation

Avdet, *Crimean Tatars cherish their language so much that they don't even speak it* (24 June 2013), available at: <https://avdet.org/2013/06/24/krymskie-tatary-nastolko-beregut-svoj-yazyk-cto-dazhe-ne-razgovarivayut-na-nem/>.

Author Uriye Ablа

Crimean Tatars cherish their language so much that they don't even speak it

24.06.2013 8:06

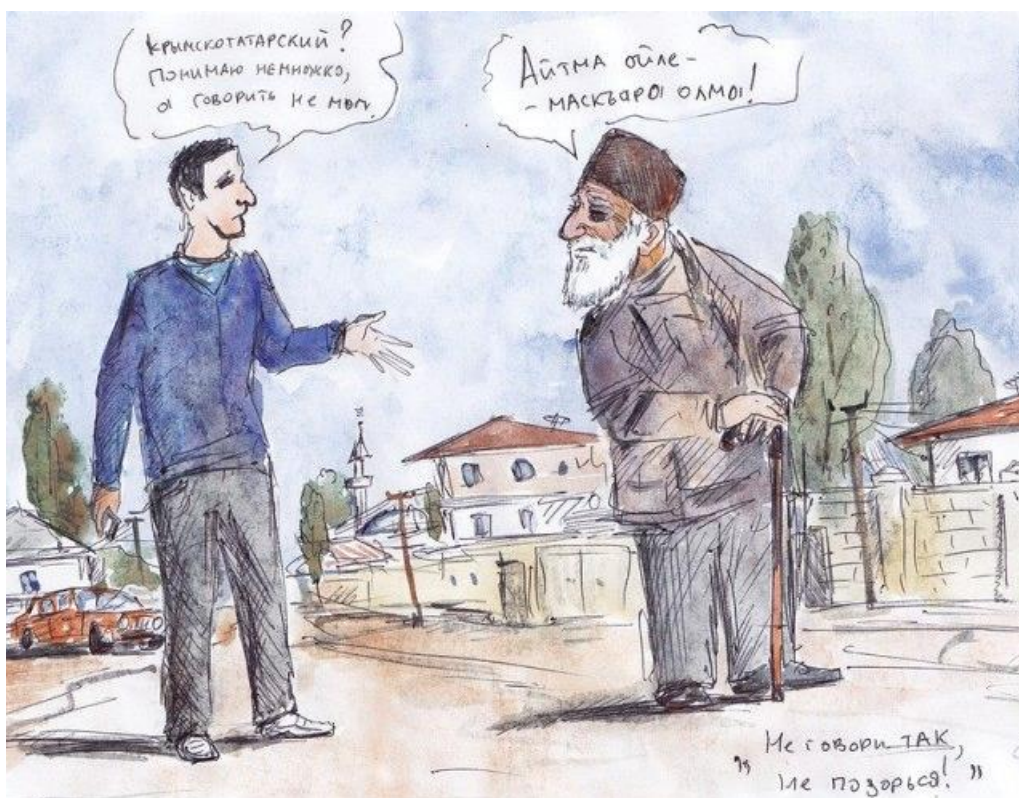

This year there was not a single person willing to take the external independent assessment in Crimean Tatar, even though 3.1% of people in Crimea study in Crimean Tatar. This can be explained by the fact that the teaching was not of the highest quality.

“Being taught in Crimean Tatar” is a strong phrase, as there are neither textbooks nor qualified specialists who could teach all the subjects in the Crimean Tatar language, or appropriate salaries for them.

This was confirmed by deputy education minister of Crimea, Vladimir Buyakevich: *“Those who studied in Crimean Tatar did not receive proper education for a number of subjective and objective reasons, so those willing to take the risk were not found.”*

It is even beneficial for our authorities that there are none, because, as Tabachnik himself says, some applicants mock the state, because it is not cheap to translate all test tasks into, say, Polish, Hungarian or Crimean Tatar.

"For example, one applicant applied to write one test in Crimean Tatar, another in Hungarian, and yet another in Polish. The logical question is: why are you doing this? Especially since he said he was not going to apply to any college. The answer was very simple: I want to check my level of knowledge of these languages. The resident of Kiev registered and chose the Crimean Tatar language to write tests in Kiev in mathematics, physics and chemistry ... he reported that his choice was motivated by a desire to express support for the Crimean Tatar people," genuinely wonders the high official.

Thus the government's activity is simply aimed at saving as much money as possible.

Yet at the same time they tell us: "Study!" and open national classes, doing a disservice.

Our detractors constantly reiterate: *"Your children will be outcasts if they learn the Crimean Tatar language."* These arguments affect many parents who refuse to send their children to kindergartens and schools with instruction in Crimean Tatar. They fear that their children will not find a use for their knowledge of their native language. We know that if our children do not learn their mother tongue, their own language, and the younger generation keeps away from it and does not speak it, they will definitely become mankurts.

Thank Allah, and we now have facts to use in our arguments in favour of learning the Crimean Tatar language. If parents are worried about their children's employment, let them look at the rapidly developing field of media, where people who are fluent in the Crimean Tatar language are finding themselves.

Less than a month ago, the first Crimean Tatar children's channel was launched. The editor of "Lale" Usniye Khalilova complained in an interview that there were very few children who spoke Crimean Tatar. And at the same time, she praised and rejoiced for those children who achieved such a level of language knowledge that they can feel at ease on air.

Today there is a phrase on the internet: ***"Crimean Tatars cherish their language so much that they don't even speak it."***

There are several solutions for those wishing to improve their knowledge of the Crimean Tatar language:

- let your desk book be a Russian-Crimean-Tatar and Crimean-Tatar-Russian dictionary;
- bookmark the excellent Crimean informational and educational portal crimean.org with an online translator;
- each of you is registered on social networks, add the community "TIL MEKTEBI", where every day they offer 10 words to enrich your Crimean Tatar vocabulary;
- do not ignore newspapers, magazines in the Crimean Tatar language, radio "Meydan", "ATR" and "Lale" TV channels;
- Read one poem or work by a Crimean Tatar writer a day;
- communicate with old people who know dialectal versions of Crimean Tatar;
- unite in youth organisations to communicate and revive the literary language;
- respond to "Hello" with "Selam aleikum";

- Replace the usual “mum-dad” with “ana-baba”;
- help the younger ones to learn the Crimean Tatar language;
- Do not judge those who do not speak their native language, but explain to them a future without Crimean Tatar.

Annex 122

Interfax, *Crimean Historical Textbook to Get Rid of Chapter Insulting Crimean Tatars*
(6 May 2019)

(translation)

Translation

Interfax, *Crimean Historical Textbook to Get Rid of Chapter Insulting Crimean Tatars* (6 May 2019), available at: <https://www.interfax.ru/russia/660292>.

Interfax

In Russia

6 May 2019 at 01:08 PM

Crimean Historical Textbook to Get Rid of Chapter Insulting Crimean Tatars

Updated at 04:21 PM

Poroshenko Proposed to Grant Crimean Tatars Autonomy within Ukraine

Moscow. 6th of May. *INTERFAX.RU* – The Crimean authorities promised to remove from a school history textbook a chapter describing the role of the Crimean Tatars in the Great Patriotic War, which caused a wave of criticism on the peninsula.

“The decision was made in order to prevent an interethnic conflict. This chapter, which is devoted to collaborationism, will be removed from the textbook. That will be done by the beginning of the academic year”, the press service of the Crimean Ministry of Education, Science and Youth told Interfax on Monday.

The removal of the controversial pages containing “incorrect” information was previously proposed by a group of experts formed to study the textbook in dispute.

In mid-February, the Council of Crimean Tatars asked Sergey Aksyonov, the head of the Crimea, to remove from all school and public libraries the textbook “History of the Crimea for Tenth Graders”. The Council was outraged by the fact that this book describes the Crimean Tatars as collaborationists who actively co-operated with the German occupation troops.

The controversial textbook was published by Prosvescheniye Publishing House in 2018. Its authors and scientific and editorial board experts include Crimean scientists and politicians. The project is stated to be co-ordinated by Ayder Ablyatipov, Deputy Minister of Education, Science and Youth of the Crimea.

However, according to the Russian Ministry of Education, the textbook that caused the complaints is not on the federal list of textbooks.

Deportation of Crimean Tatars

In May 1944, the Crimean Tatar people were subjected to deportation by decree of Joseph Stalin. More than 190,000 people were evicted from the Crimea to Central Asia, Siberia and the Urals and accused of mass collaboration with the Nazis and the massacre of Soviet partisans. During the war, Germans, Armenians, Bulgarians and Greeks were also evicted

from the Crimea.

In late 1980s, the Soviet authorities rehabilitated the Crimean Tatars, and they began to return to the peninsula. Currently, 1.9 million people live in the Republic of Crimea, and Crimean Tatars account for about 15% of them.

Annex 123

Roskomnadzor, *232 Registered Media Outlets Operating in Crimea* (2 April 2015)

(translation)

Translation

Roskomnadzor, 232 Registered Media Outlets Operating in Crimea (2 April 2015), available at: <https://rk.gov.ru/ru/article/show/1502>.

232 Registered Media Outlets Operating in Crimea – Roskomnadzor

02.04.2015

In the Crimean Federal District, the transitional period of media registration ended on 1 April 2015.

To date, the Federal Service for Supervision of Communications, Information Technology and Mass Media (Roskomnadzor) has registered 232 media outlets in Crimea: 8 online publications, 19 television channels, 42 radio channels, 163 print media and news agencies.

Of this number, 207 media outlets had permits issued under Ukrainian legislation and were re-registered; 25 registered media outlets are Russian media outlets that entered the peninsula media market for the first time (one network publication, two TV channels, 8 radio channels and 14 print media outlets and news agencies).

As a reminder, in November 2014, the Russian State Duma decided to extend the transition period for Crimean media until 1 April 2015.

During this period, the registration of the media whose products are intended for distribution in the territory of the constituent entities of the Russian Federation - the Republic of Crimea and the city of federal significance Sevastopol - was carried out under a special procedure, without payment of state duty. During the transitional period, the Ukrainian permits were in force.

Media registration in Crimea continues in accordance with the general procedure stipulated by the legislation of the Russian Federation. Please note that the registration documents sent by post before 1 April 2015 (with the appropriate postal stamps) will be considered under the special procedure in force before the reporting date.

Annex 124

Roskomnadzor, Letter No. 571-05-91, 26 March 2015

(translation)

Translation

Roskomnadzor, Letter No. 571-05-91, 26 March 2015.

**ROSKOMNADZOR
Administration of the Federal Service for Supervision in the Sphere of Telecom,
Information Technologies and Mass Communications for the Republic of Crimea and the
City of Sevastopol
(Roskomnadzor Administration for Crimea and Sevastopol)**

295000, Republic of Crimea, Simferopol, Ulitsa Vilar, 4
E-mail: rsockanc82@rkn.gov.ru

No. 571-05/91 dated 26.03.2015

To: Sh.E. Kaibullayev,
Address: 297540, Republic of Crimea, Simferopol District,
Rodnikovo Village, Ulitsa Sumskaya, 38

Dear Shevket Enverovich,

The Roskomnadzor Administration for Crimea and Sevastopol has carefully reviewed your documents for the registration of the print media, i.e. newspaper 'Avdet', and, in accordance with Art. 13 of the Law of the Russian Federation #2124-1 of 27 December 1991 'On Mass Media', hereby informs you that registration is denied (Order of Roskomnadzor #6-smk dated 26.03.2015 'On decisions of the Federal Service for Supervision in the Sphere of Telecom, Information Technologies and Mass Communications on issues of registration of mass media') on the following grounds:

- the information provided in the application is untrue.

Head (digital signature)

S.N. Khudolei

Annex 125

Roskomnadzor, Report on Registration of Media Outlets, 3rd Quarter of 2017

(translation)

Excerpt
Translation

Roskomnadzor, Report on Registration of Media Outlets, 3rd Quarter of 2017, available at: <https://rkn.gov.ru/mass-communications/smi-registration/p885/>

Registration of Media Outlets in the 3rd Quarter of 2017

In the 3rd Quarter (in 9 months) of 2017, territorial departments have excluded 994 (3 294) mass media outlets, from which:

- 540 (1 714) – by judicial decision;
- 454 (1 580) – by owner's (owners') decision.

Annex 126

Bez Formata, *Crimean Schools Got Over 80,000 Textbooks in Crimean Tatar Language*
(16 January 2018)

(translation)

Translation

Bez Formata, *Crimean Schools Got Over 80,000 Textbooks in Crimean Tatar Language* (16 January 2018), available at: <https://simferopol.bezformata.com/listnews/uchebnikov-na-krimsko-tatarskom-yazike/64134790/>.

Crimean Schools Got Over 80,000 Textbooks in Crimean Tatar Language



Photo: *the-1.ru*

81,000 textbooks in the Crimean Tatar language, which have been prepared and printed with RUB 50 mln allocated from the budget of the Republic of Crimea, have now been delivered to the peninsula, the Ministry of Education, Science and Youth of the Republic of Crimea told *3652.ru*'s reporter. 36 textbook titles for schoolchildren of the first through ninth grades have been printed. 50 experts in the Crimean Tatar language and literature, including professors, associate professors and teachers of the V.I. Vernadsky Crimean Federal University's Tavrida Academy and the Crimean Engineering and Pedagogical University as well as leading schoolteachers have been engaged in the project. The books have been published by Prosvescheniye Publishing House. The kit consists of a textbook on the native language and literature, a chrestomathy, and a study guide for teachers. Students and teachers at Crimean schools began to use those books in their educational process as soon as in this January. Note that the schools had previously used translated textbooks.

This material was published on *BezFormata* on the 11th of January 2019. The date when it was published on the original source's website is stated below:

Source: [Pervy Krymsky](#)

16.01.2018 at 11:52 AM

Annex 127

Roskomnadzor, Report on Registration of Media Outlets, 4rd Quarter of 2017

(translation)

Excerpt
Translation

Roskomnadzor, Report on Registration of Media Outlets, 4rd Quarter of 2017, available at: <https://rkn.gov.ru/mass-communications/smi-registration/p885/>.

Registration of Media Outlets

In the **4th Quarter of 2017**, territorial departments have excluded 873 mass media outlets, from which:

- 421 – by judicial decision
- 452 – by owner's (owners') decision

Annex 128

Roskomnadzor, *232 Registered Media Outlets Operating in Crimea* (2 April 2015)

(translation)

Translation

Roskomnadzor, 232 Registered Media Outlets Operating in Crimea (2 April 2015), available at: <https://rk.gov.ru/ru/article/show/1502>.

232 Registered Media Outlets Operating in Crimea – Roskomnadzor

02.04.2015

In the Crimean Federal District, the transitional period of media registration ended on 1 April 2015.

To date, the Federal Service for Supervision of Communications, Information Technology and Mass Media (Roskomnadzor) has registered 232 media outlets in Crimea: 8 online publications, 19 television channels, 42 radio channels, 163 print media and news agencies.

Of this number, 207 media outlets had permits issued under Ukrainian legislation and were re-registered; 25 registered media outlets are Russian media outlets that entered the peninsula media market for the first time (one network publication, two TV channels, 8 radio channels and 14 print media outlets and news agencies).

As a reminder, in November 2014, the Russian State Duma decided to extend the transition period for Crimean media until 1 April 2015.

During this period, the registration of the media whose products are intended for distribution in the territory of the constituent entities of the Russian Federation - the Republic of Crimea and the city of federal significance Sevastopol - was carried out under a special procedure, without payment of state duty. During the transitional period, the Ukrainian permits were in force.

Media registration in Crimea continues in accordance with the general procedure stipulated by the legislation of the Russian Federation. Please note that the registration documents sent by post before 1 April 2015 (with the appropriate postal stamps) will be considered under the special procedure in force before the reporting date.

Annex 129

BBC News, *Crimea Hit by Power Blackout and Ukraine Trade Boycott* (23 November 2015)



Home

News

Sport

Reel

Worklife



Home | War in Ukraine | Coronavirus | Climate | Video | World | UK |

More

Business | Tech | Science

World | Africa | Asia | Australia | Europe | Latin America | Middle East | US & Canada

Crimea hit by power blackout and Ukraine trade boycott

🕒 23 November 2015



REUTERS

| Anti-Russian activists were accused of sabotaging four electricity pylons near Crimea

Ukraine has suspended deliveries of goods to Crimea, where a power blackout has caused major disruption.

Only essential services and government offices are operating in Crimea after key electricity pylons connected to the peninsula were knocked down in Ukraine.

Protesters, including Crimean Tatars, are preventing the repair work. Russia has warned of retaliatory measures.

Ukraine is planning new rules for cargo traffic for the southern peninsula, which was annexed by Russia in 2014.

There has been disruption to road and rail traffic to and from Crimea since Ukrainian nationalists and Crimean Tatars began a border blockade in September.

Crimean Tatar leader Mustafa Dzhemilev said the protesters would only let engineers repair two pylons that serve areas of mainland Ukraine - not the two linked to Crimea.

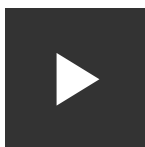

| People in Crimea explain how the power blackout has affected them

Russia does not have a land border with Crimea, which gets about 70% of its electricity from Ukraine.

Economic impact

Most of Crimea's two million people have been hit by the power cut. There are also water shortages.

Public transport is still running and hospitals are using generators. But the blackout has shut down many businesses and plunged the streets into darkness.

A state of emergency was imposed on Sunday and Monday was declared a non-working day.



The blackout forced the closure of some 150 schools.

"We are outraged by the cut-off... because a lot of us have electric cookers, we can't wash properly at the moment... our fridges are defrosting," Sevastopol resident Raisa Kazhyrnova told Reuters news agency.

Ukraine's state energy company, Ukrenergo, said the damage to the pylons was caused by "shelling or the use of explosive devices".



AFP

Crimea's capital Simferopol was plunged into darkness



REUTERS

A Crimean Tatar flag was tied around a damaged pylon in Kherson

Trade tensions

Ukrainian PM Arseniy Yatsenyuk said the government "is temporarily banning cargo traffic on the administrative border" between Ukraine and Crimea.

He also warned Ukraine would respond in kind if Russia introduced an

embargo on Ukrainian products, as Moscow has threatened to do.

Russia is angry at Ukraine's decision to implement a free trade agreement with the EU on 1 January 2016.

Russia says the deal will undermine its producers, because EU exporters are likely to use Ukraine as a back door into the Russian market.

Russia has blamed Ukrainian nationalists and Crimean Tatar activists for the pylon damage, calling it "an act of terrorism".

Crimean Tatar activists said Russia must release "political prisoners" and let their leaders return to Crimea in exchange for the repair work.

Emergency timetable

Crimean Tatar activists accuse Russia of abusing their rights.



REUTERS

| An electrical shop in Simferopol is among many businesses temporarily shut down by the emergency

Crimean authorities said they had managed to partially reconnect some cities using generators.

But emergency power-saving measures have been imposed across the peninsula.

Russia has started laying undersea cables to connect Crimea to its power grid. But the first phase will only take effect next month and the switch to Russia as the main supplier will take several years to complete.

Annex 130

Roskomnadzor, *483 Registered Media Outlets Operating in Crimea* (18 March 2017)

(translation)

Translation

Roskomnadzor, 483 Registered Media Outlets Operating in Crimea (18 March 2017), available at: <https://rkn.gov.ru/news/rsoc/news43573.htm>.



**FEDERAL SERVICE FOR SUPERVISION OF COMMUNICATIONS,
INFORMATION TECHNOLOGY, AND MASS MEDIA**

Home > News > *Roskomnadzor's* News

483 Registered Media Outlets Operating in Crimea

18 March 2017 at 04:28 PM



In the Crimea, 483 mass media outlets have been registered since the date it became part of the Russian Federation. At present, 448 media outlets are operative, including 56 in the Crimean Tatar language.

56 licences have been issued to Crimean broadcasters, including 25 TV broadcasting and 31 radio broadcasting channels.

Mass media registrations in the Crimea go on in accordance with the general procedures prescribed by Russian laws.

Annex 131

Avdet, Newspaper No 27 of 29 September 2020 (30 September 2020)

(translation)

Translation

***Avdet, Newspaper No 27 of 29 September 2020 (30 September 2020), available at:
<https://avdet.org/2020/09/30/gazeta-avdet-27-ot-29-sentjabrja-2020-g/?ysclid=lebw79adfa743254355>.***

Published since 15 July 1990

Avdet

No. 27 (1117) 29 September 2020

Let's work on our future!

Ulviye, Damir, Evelina, Adile

Annex 132

Millet, *Vatan Khatirasi* (17 February 2023)

(translation)

Translation

**Millet, *Vatan Khatirasi* (17 February 2023), available at:
<https://trkmillet.ru/programs/vatan-khatirasi/>.**

Vatan Khatirasi

The examples of lives and activities of the great ancestors of ancient times were used as the ground for upbringing of the younger generation. Their deeds inspired the youth for new achievements and accomplishments. Today we cherish the memory of great personalities of the Crimean Tatar people, who have left an indelible trace in the history of in the history of our homeland.

Releases

" Vatan Khatirasi" Refat Chailak. Release dated 11.02.23

Annex 133

Millet, *History of the Crimean Tatars Programme* (17 February 2023)

(translation)

Translation

Millet, *History of the Crimean Tatars Programme* (17 February 2023), available at: <https://trkmillet.ru/programs/istoriya-krimskikh-tatar/>.

"THE HISTORY OF THE CRIMEAN TATARS"

The program is about the life of the people during the Crimean Khanate, about preserved monuments, even closer acquaints with the cultural past. Old mosques and palaces, fountains and gardens, bathhouses and schools. A people who doesn't know its history has no future.

Releases

"The History of the Crimean Tatars" Release dated 21.12.21 Karasubazar

Annex 134

Millet, *Crimean family* (17 February 2023)

(translation)

Translation

Millet, *Crimean family* (17 February 2023), available at:
<https://trkmillet.ru/programs/krimskaya-semya/>.

"CRIMEAN FAMILY"

Crimea is a unique place of convergence of cultures and religions. An area with centuries-old history. Our place of strength. Unique open-air museum. Common home of our big Crimean family. Let's learn the traditions of the people of our peninsula together. Don't miss it. Every Saturday at 12:00. The Crimean Family project on Millet TV.

Releases

"Crimean family" Release dated 27.02.21 Mordva

"CRIMEAN FAMILY" Release dated 20.02.21 RUSSIANS

Annex 135

Millet, *Kirimda Bayram* (17 February 2023)

(translation)

Translation

Millet, *Kirimda Bayram* (17 February 2023), available at:
<https://trkmillet.ru/programs/kirimda-bayram/>.

"KIRIMDA BAYRAM"

Releases

"Kirimda Bayram" Release 8 dated 24.10.21

"Kirimda Bayram" Release 7 dated 17.10.21

Annex 136

Millet, *Millet Bereketi* (17 February 2023)

(translation)

Translation

Millet, *Millet Bereketi* (17 February 2023), available at: <https://trkmillet.ru/programs/millet-bereketi/>.

"MILLET BEREKETI"

"Millet Bereketi" is a culinary program that is a treasury of interesting stories, emotions and various dishes. Here are some helpful tips and tricks to add delicious meals to your busy schedule. Be happy with us!

Every Thursday at 19:00 " Millet Bereketi" on "Millet" TV channel.

Releases

" Millet Bereketi" Release dated 25.06.21 Emine Gazieva

" Millet Bereketi" Release dated 19.06.21 Dinara Ablyakimov

Annex 137

Millet, *The Peoples of Crimea: Diversity of Unity* (17 February 2023)

(translation)

Translation

Millet, *The Peoples of Crimea: Diversity of Unity* (17 February 2023), available at: <https://trkmillet.ru/programs/narodi-krima-raznoobrazie-edinstva/>.

"THE PEOPLES OF CRIMEA: DIVERSITY OF UNITY"

On the culture and traditions of the peoples of the Crimean Peninsula. Their centuries-old history and modern life. Learn about it in the programme "The Peoples of Crimea: Diversity of Unity".

Releases

"The Peoples of Crimea: Diversity of Unity" Greeks. Release dated 13.02.23

"The Peoples of Crimea: Diversity of Unity" Armenians. Release dated 06.02.23

Annex 138

Millet, *Prime Time* (17 February 2023)

(translation)

Translation

Millet, *Prime Time* (17 February 2023), available at: <https://trkmillet.ru/programs/praym-taym>.

"PRIME TIME"

Exclusives and stories, topical issues of the day. The important, topical, pressing, joyful and forward-looking things will be covered in detail and without any cuts.

Watch it on weekdays at 18:45 on Millet TV.

Releases

"Prime Time" Release dated 16.02.23 Natalia Kropotova

"Prime Time" Release dated 15.02.23 Sergey Tarasov

Annex 139

Millet, *Seya*at (17 February 2023)

(translation)

Translation

Millet, *Seya*at (17 February 2023), available at: <https://trkmillet.ru/programs/instaseyaat/>.

"SEYAAT"

A bright travel project of Millet TV! We're ready to tell you about the most popular places for your unique photos.

Releases

"Seya

"Seya

Annex 140

Millet, *Tarikh Izleri* (17 February 2023)

(translation)

Translation

Millet, *Tarikh Izleri* (17 February 2023), available at: <https://trkmillet.ru/programs/tarikh-izleri/>.

"TARIKH IZLERI"

"Tarikh Izleri" is a unique project that tells the story of old Crimean Tatar villages. Every time we travel to a remote corner of Crimea, we get to know local people better, share their life stories and traditions of one or another settlement. We would love to come to your village too!

Releases

" Tarikh Izleri" Vladimirovka. Release dated 12.02.23

" Tarikh Izleri" Old Town 2. Release dated 05.02.23

Annex 141

Millet, *Tek Arzum Vatan* (17 February 2023)

(translation)

Translation

Millet, *Tek Arzum Vatan* (17 February 2023), available at: <https://trkmillet.ru/programs/tek-arzum-vatan/>.

"TEK ARZUM VATAN"

"Tek Arzum Vatan!" – the field of cultural studies. The project is the culture, traditions and customs of the Crimean Tatar people, popularization of national principles.

Notes from curious people about the culture and customs of the Crimean Tatar people.

Releases

" Tek Arzum Vatan!" Release dated 09.02.23 Izzet Vaitov

" Tek Arzum Vatan!" Release dated 02.02.23 Eldar Ibrahimov

Annex 142

Millet, *Yurt Nefesi* (17 February 2023)

(translation)

Translation

Millet, *Yurt Nefesi* (17 February 2023), available at: <https://trkmillet.ru/programs/yurt-nefesi/>.

"YURT NEFESI"

The breath of the home is a TV show that introduces the people who live the spiritual variety of our country and breathe life into it, that is, famous linguists, writers, cultural, religious and community leaders. Early Friday, 8:30 p.m

Muellifi — Edie Memetova.

Releases

"Breath of home" Release dated 10.02.23 Zubeir Qadri-Zadeh

"Breath of home" Release dated 03.02.23 Vaade Mustafaeva

Annex 143

Millet, *Yaylya Boyu* (17 February 2023)

(translation)

Translation

Millet, *Yalya Boyu* (17 February 2023), available at: <https://trkmillet.ru/programs/yalya-boyu/>.

"YALYA BOYU"

Every Saturday at 20.00

Talented artists, rocking dances of the best collectives of the Crimean Tatar people. See the revival and development of the national art of the Crimean Tatars in the programme " Yalya Boyu " every Saturday at 20:00

Releases

" Yalya Boyu" Emir Emiruseinov Release dated 24.09.22

" Yalya Boyu" Rustem Ebazerov Release dated 17.09.22

Annex 144

Millet, *Chalgidzhi Live* (17 February 2023)

(translation)

Translation

Millet, *Chalgidzhi Live* (17 February 2023), available at:
<https://trkmillet.ru/programs/chalgidzhi-live/>.

"CHALGIDZHI LIVE"

The musical group Chalgydzhy professionally performs Crimean Tatar folk songs and also helps audiences learn the intricacies of national Crimean Tatar music.

Releases

"Chalgidzhi Live" 15.09.2022

"Chalgidzhi Live" 08.09.2022

Annex 145

Millet, *Ana Yurtun - Altin Beshik* (17 February 2023)

(translation)

Translation

Millet, *Ana Yurtun - Altin Beshik* (17 February 2023), available at: <https://trkmillet.ru/programs/ana-yurtun-altin-beshik/>.

"ANA YURTUN – ALTIN BESHİK"

"Ana Yurtun - Altin Beshik " is our interesting story. The thoughts and worldview of the Crimean Tatars, the philosophy of verse... Watch it tomorrow on our "Millet" TV channel!

Releases

"Ana Yurtun - Altin Beshik ". Release 38. Enver Umerov

" Ana Yurtun - Altin Beshik". Release 37. Ernest Prtykhov

Annex 146

Millet, *Diniy Subet* (17 February 2023)

(translation)

Translation

Millet, *Diniy Subet* (17 February 2023), available at: <https://trkmillet.ru/programs/diniy-subet>.

"DINIY SUBET"

A religious-educational information programme. The programme not only deals with the basics of Islam and the way of the Prophet Muhammad (s.a.w.), but also provides answers of interest to the society through the prism of Islam. The program covers topics like worship, the history of Islam, art in Islam, parenting issues, extreme views and addictions, the canons of Islamic morality and ethics.

The programme "Diniy Subet" is hosted by Aider Ismailov, Master of Islamic Law and Deputy Mufti of Crimea.

Releases

"Diniy Subet". Release dated 10.02.23

Annex 147

Millet, *The World of Islam* (17 February 2023)

(translation)

Translation

Millet, *The World of Islam* (17 February 2023), available at: <https://trkmillet.ru/programs/mir-islama/>.

"THE WORLD OF ISLAM"

Religious-educational programme "The World of Islam". The history of religion, the basic provisions, education of spirituality and doctrine of Islam. On Tuesdays, at 18:45 with the Deputy Mufti of Muslims of Crimea Esadullah Bairov.

Releases

"The World of Islam". Release 30.

"The World of Islam". Release 29.

Annex 148

Millet, *Khizmet ve Bereket* (17 February 2023)

(translation)

Translation

**Millet, *Khizmet ve Bereket* (17 February 2023), available at:
<https://trkmillet.ru/programs/khizmet-ve-bereket/>.**

"KHIZMET VE BEREKET"

The new programme "Khizmet ve Bereket" is about the work of religious figures. Every week our guests share their stories with the audience. Friday at 20:00. Don't miss out!

Releases

"Khizmet ve Bereket". Lyoman Vefaev. Release dated 10.02.23.

"Khizmet ve Bereket". Eldar Adjibekirov. Release dated 03.01.23.

Annex 149

Millet, *Millet Khatirly* (17 February 2023)

(translation)

Translation

**Millet, *Millet Khatirly* (17 February 2023), available at:
<https://trkmillet.ru/programs/millet-khatirly/>.**

“MILLET KHATIRLAY”

Releases

“Millet Khatirly”. Shevkhie Shemshedinova

“Millet Khatirly”. Shazie Yagyaeva

Annex 150

Millet, *Miras* (17 February 2023)

(translation)

Translation

Millet, *Miras* (17 February 2023), available at: <https://trkmillet.ru/programs/miras/>.

“MIRAS”

"Miras" is an educational program. Bright and sophisticated paintings on the canvases of talented painters, Crimean art described in the works of poets, love of the country, works of craftsmen and hidden, sacred examples in their publications - describe the great history and culture of our people.

On Saturday, at 20:00, the author of Leykha, Elmara Mustafa, will introduce you to this rich Crimean tradition.

Releases

MIRAS. The fine art of calligraphy

MIRAS. Embroidery is a wonderful world

Annex 151

Millet, *Yerketai* (17 February 2023)

(translation)

Translation

Millet, *Yerketay* (17 February 2023), available at: <https://trkmillet.ru/programs/yerketay/>.

“YERKETAY”

Do you want to meet the peninsula's most talented people? And to learn the Crimean Tatar language, find out recipes for the healthiest and tastiest dishes which kids can cook, and just watch interesting stories?

We invite all our viewers - children and adults alike - to watch the "Yerketay" children's program.

Make your weekends fun, exciting and useful!

Releases

"Yerketay" Guzel. Release dated 11.02.2023

Annex 152

Millet, *Yuku Time* (17 February 2023)

(translation)

Translation

**Millet, *Yuku Time* (17 February 2023), available at:
<https://trkmillet.ru/programs/yukutime/>.**

“YUKU TIME”

Darkness will fall on the earth, the stars will be bright, Kunesh will sleep, and our children will be born.

We will help them with Setmer in this work. Every day at nine o'clock in the evening, let your burdens from us be sweet.

Releases

"Yuku Time" Release dated 16.02.2023 No. 303

"Yuku Time" Release dated 15.02.2023 No. 302

Annex 153

Millet, *Documentary "The Long Way Home"* (18 May 2022)

(translation)

Translation

**Millet, *Documentary "The Long Way Home"* (18 May 2022), available at:
<https://trkmillet.ru/program-episode/dokumentalniy-film-dolgaya-doroga/>.**

DOCUMENTARY "THE LONG WAY HOME"

18.05.2022

In the history of each nation there are events and dates that must not be forgotten. They cannot be forgotten. In the history of the Crimean Tatars such date was on May 18, 1944, when the entire nation was subjected to sweeping accusations, forcibly exiled from Crimea. The return to the homeland has dragged on for a long 45 years.

The witnesses of the tragic events of May 1944 tell us what the way home was like in the documentary "The Long Way Home".

Author: Zera Emirsuin

Director: Maxim Zamotokhin

Production by Millet TV

Annex 154

Millet, *Documentary "Fevzi Bilyalov: Singer for All Times..."* (5 November 2022)

(translation)

Translation

Millet, Documentary "*Fevzi Bilyalov: Singer for All Times...*" (5 November 2022), available at: <https://trkmillet.ru/program-episode/dokumentalniy-film-fevzi-bilyalov/>.

DOCUMENTARY "FEVZI BILYALOV: SINGER FOR ALL TIMES"

The concert halls of Tashkent, Samarqand, Fergana, Bukhara, Namangan and later the entire Soviet Union applauded him.

A man of legend!

Nightingale of the Crimean Tatar people!

He is a true son of his Motherland!

The TV channel "Millet" presents to your attention a documentary film "Fevzy Bilyalov: a singer for all times".

In the year of the 90th anniversary of the legendary Crimean Tatar singer, People's Artist of the Uzbek SSR, People's Artist of Ukraine Fevzi Bilyalov.

05.11.2022, 20:30

Annex 155

Investigative Journalism Centre, *BSTRC Threatened with Discontinuation of Broadcasting in Crimea* (13 January 2014)

(translation)

Translation

Investigative Journalism Centre, *BSTRC Threatened with Discontinuation of Broadcasting in Crimea* (13 January 2014), available at: <https://investigator.org.ua/news/114144/>.

BSTRC Threatened with Discontinuation of Broadcasting in Crimea, Investigative Journalism Centre Reports

This is said in a statement of Radio and TV Transmitting Centre (RTTC), which has been sent to Investigative Journalism Centre's editorial office.

According to that statement, Black Sea TV & Radio Company (BSTRC) owed RTTC UAH 1.6 mln as of early January. Under the agreement between the two companies, if BSTRC fails to repay its debt for the services actually provided for it in an accounting month within the following month, RTTC may suspend serving BSTRC upon five-day prior notice until it repays its debt.

In addition, RTTC may stop providing its services if the total amount in arrears exceeds 25% of the annual payment upon 10-days prior notice.

“Since any further broadcasting of BSTRC's programmes without getting paid for our services will result in our company becoming unable to pay electricity bills and wages to our employees, RTTC has to exercise its legal right to take tough measures. In the event that the debt owed by BSTRC is not repaid by 21 January 2014, we will stop broadcasting its programmes from 00:00 on 22 January 2014”, the statement said.

RTTC stressed it had made its statement “to prevent any political speculations and false accusations of exerting a pressure on a private TV and radio company” and called media “not to allow the situation to turn into a political conflict”.

Investigative Journalism Centre has reported earlier that BSTRC, which is part of the media holding owned by Andriy Senchenko, a member of the Verkhovna Rada of Ukraine from the united opposition, and his business partners, was established by B.S. Holding Ltd. and Black Sea Advertising Information Agency in December 1993. Today, its broadcasting covers almost the entire Crimea and its audience exceeds one million viewers. Since December 2011, BSTRC has begun satellite broadcasting, but, like many other opposition TV and radio broadcasters, has been unable to get a digital broadcasting licence.

BSTRC encountered a critical situation with financing in late 2010 after the change of power in Ukraine. The businesses of the key supporters for Yulia Tymoshenko Bloc in the Crimea were then subjected to a powerful pressure from law enforcement agencies, resulting in a reduction of investments in the company, who had to cut its staff and incur debts on wages to its remaining employees.

Annex 156

Investigative Journalism Centre, *Employees of BSTRC, Crimea's Largest TV Company, Walked Out* (7 February 2013)

(translation)

Translation

Investigative Journalism Centre, *Employees of BSTRC, Crimea's Largest TV Company, Walked Out* (7 February 2013), available at: <https://investigator.org.ua/en/news/72786/>.

Employees of BSTRC, Crimea's Largest TV Company, Walked Out, Investigative Journalism Centre Reports



Employees of Black Sea TV & Radio Company (BSTRC), which is associated with Lyudmila Denisova and Andriy Senchenko, two members of the Verkhovna Rada of Ukraine, began a strike in the Crimea, *Krym.Kommentarii* reports.

Currently, they are broadcasting archival programmes and say no news will be aired today.

According to Vladimir Andronaki, a journalist, Elena Titarenko, President of BSTRC, was notified of today's strike in case the company fails to pay all wages in arrears to its employees.

"I personally said this to Mrs Titarenko, President of BSTRC, in front of witnesses. She replied she knew about our demands and the strike. She made it clear that they were not going to pay any money to journalists for the time being", Mr. Andronaki wrote on his Facebook page.

In turn, Andriy Senchenko said BSTRC was still working and the rioters were financed by his political opponents. "Everything is going as it should go. All normal people will work quietly and receive wages. There is no such problem", he said in an interview with *Krym.Kommentarii*.

"Everything is fine, we are working", he replied to a clarifying question whether any news releases will be broadcast today.

Annex 157

Taurica.net, *BSTRC Begins Repaying Debts to RTTC* (20 January 2014)

(translation)

Translation

Taurica.net, *BSTRC Begins Repaying Debts to RTTC* (20 January 2014), available at: <https://taurica.net/90873-Chernomorskaya-teleradiokompaniya-nachala-oplachivat-dolgi-pered-RTTC.html/>.

BSTRC Begins Repaying Debts to RTTC

Black Sea TV & Radio Company (BSTRC) has begun repaying its debts owed to Radio and TV Transmitting Centre (RTTC), a state-owned company. By today, UAH 500,000 has been paid, amounting to almost one third of the total indebtedness, Sergey Dotsenko, Director of RTTC, said.

“The debt owed to us by a private TV and radio company in the amount of UAH 1,600,000 as of early January this year deprived us of the possibility to pay electricity bills and wages to our employees, jeopardising the broadcasting of other TV channels in the Crimea”, he said. “By today, UAH 500,000 has been paid. But the debt must be paid in full, otherwise the issue with disabling BSTRC’s broadcasting will be raised again”.

According to Investigative Journalism Centre, RTTC did not rule out the discontinuation BSTRC’s broadcasting from the 22nd of January. As of the beginning of January, BSTRC owes RTTC UAH 1.6 mln. Under the agreement between the two companies, if BSTRC fails to repay its debt for the services actually provided for it in an accounting month within the next month, RTTC may suspend serving BSTRC upon five-days prior notice until it repays its debt, RTTC’s statement says.

BSTRC’s management made it clear the issue with the possible shutdown of the broadcasting due to the debt owed by BSTRC for the services provided for it by RTTC will be resolved.

This publication is based on Investigative Journalism Centre’s news reports.

Annex 158

Odessa Crisis Media Center, *“We’ll Return Crimea in 2016”, Says Lenur Islyamov* (25
December 2015)

(translation)

Translation

Odessa Crisis Media Center, *“We’ll Return Crimea in 2016”, Says Lenur Islyamov* (25 December 2015), available at: [https://web.archive.org/web/20160207145939http://www.odcrisis.org/lenur-islyamov2/](https://web.archive.org/web/20160207145939/http://www.odcrisis.org/lenur-islyamov2/).



“We’ll Return Crimea in 2016”, Says Lenur Islyamov

This entry was made in News on 25 December 2015 by Alena Balaba, our author, and tagged as “Odessa”, “Noman Çelebicihan Battalion”, “blockade of Crimea”, “civil blockade of Crimea”, “Krim”, “Crimea”, “Lenur Islyamov”, “Naval blockade of Crimea”, “Odessa”, “customs”, “ports”, “Chonhar” and “energy blockade”.

A plan to return the occupied and annexed Crimea is ready; a food blockade is successfully maintained, the peninsula receives electricity in a metered manner, a volunteer battalion is being formed in the border zone, and activists plan to impose a naval blockade in the near future. Read the details in our publication.

The blockade of the occupied and annexed peninsula began as early as on the 20th of September, when Crimean Tatars, who are persecuted in every possible way by Russian occupiers, blocked the roads leading to the peninsula, preventing trucks carrying food from passing. Mass media were full of various information with assessments and criticism of the civil blockade of the Crimea imposed by activists. Soon Azov and Right Sector members joined Crimean Tatars in their efforts to maintain the blockade, with the Armed Forces of Ukraine and Ukrainian border guards also supporting the blockade. On the 21st of November, unknown persons blew up the four power line pylons supplying electricity to the occupied peninsula in Chaplynka, Kherson Region, resulting in a long-time blackout. Following their old tradition, Russian propagandists began to threaten and blackmail the activists, launching various fake news. At the moment, one power line to the Crimea has been restored, and the peninsula still receives electricity on an hourly basis. The food blockade is still maintained, and, according to Lenur Islyamov, the commander of the “Civil Blockade of the Crimea” movement’s headquarters, the invaders should expect a naval blockade to begin in January. Odessa Crisis Media Center’s reporters visited the site and took a detailed interview with Lenur Islyamov.

“A lot of various information is circulating, including in Ukrainian media, about the blockade of the Crimea and who benefits from it. So we want you to tell us what is going on here, what are your plans, and what you are going to do next”.

“We started the blockade consisting of three stages: the first one is a goods blockade, the second one is an electricity blockade, and the third one is a naval blockade. There was also an idea of one small blockade called the “network blockade”, but the Mejlis has not yet given its go-ahead for it because the whole Crimea will then lose the Internet connectivity. As a matter of fact, we

do not insist on it. On the 15th of December, the Cabinet of Ministers passed a resolution officially prohibiting everything from being imported into the Crimea beginning from 15 January 2016. We gave 30 days for it to become effective. The power line pylons are the next target. One 220-V line of the four disabled lines is now turned on again. We have to disable it on the 31st of December. If it is not turned off, then we will move away, removing our roadblocks everywhere, that is, the electricity should not enter the Crimea beginning from the 1st of January. We left this line for our legislators, members of the Verkhovna Rada, because we have no hope for the government. As regards the naval blockade, we want to make it very painful for the Russians. The goods blockade is transforming into civil associations that will be located in the coastal territory. We are currently forming a new volunteer battalion named after Noman Çelebicihan. We should wait to receive a military unit number to be assigned to it, but we already receive volunteer assistance as a battalion. On Friday, we will receive the first batch of Turkish military uniforms. While the Ukrainian Defence Ministry is still only fidgeting, the Turkish Defence Ministry has already begun to support us. We will get 250 sets of uniforms and boots. As soon as we get a military unit number, hopefully, by the 15th of January or so, the World Congress of Crimean Tatars will be held on Chonhar, and its executive committee will be here. All Crimean Tatars from all over the world – i.e., from America, Canada, Poland, Romania, and Turkey, about 43 countries in total, will come here, and all of them will be here, in our headquarters on Chonhar”.

“Please tell me more about your Battalion”.

“The Battalion will consist of 560 persons. They will deal with the tasks set by the General Staff. But their main task will be to protect the Crimean border inside the Crimea. We will make the Crimea closer as soon as possible. The mission of this Battalion is to strike in a way only we know. We know all trails and springs in the Crimea. Crimean Tatars in the Crimea are expected to bring the liberation of the peninsula closer. We are told, ‘wait three to four years at the international level’, but we want this to happen in one year. In three to four years, Russia will be completely devastated. We want that to happen in one year”.

“How do you plan to impose a naval blockade?”

“Ships with smuggled goods are leaving Odessa. They go to the 12-mile zone and turn off their GPS navigators. Ships from Sevastopol approach them and take their goods. That is one option. The other one is that the navigator on the ship is turned off, the ship moves on, goes into the port of Sevastopol, unload its freight, goes on the same route, turns on its navigator as if it was broken, and enters Skadovsk. And then it goes to Istanbul. Odessa customs authorities and SSU know about it. Unfortunately, people are ready to be annexed and raise Russian flags. We need to return the Ukrainian cities and towns to Ukraine”.

“How are locals responding to the blockade?”

“At first, they were scared. Russian TV channels are broadcast here, there are seven Crimean radio stations talking about the junta, Tatar-Banderites and so on. The Ukrainian information field is not protected. When we drive through the Kherson Region, they call us “Banderites”. But this is half the trouble. People do not understand what will happen to them if Russia comes here. That Russia they see on TV has long gone”.

“Please tell me, do Ukrainian border guards know about the sea smuggling?”

“I do not want to blame anyone, I just know that is happening. But I cannot figure out how all those services can be unaware of the smuggling. But this is not an easy question. We have imposed a civilian blockade of the Crimea, but on what ground border guards should detain those vessels? Even here. We have set up roadblocks illegally. Someone can speed up and ram through them. And what do we say? There is Law No. 4032, no one has abolished it. You can drive to the Crimea and bring, say, ice cream from Lviv. The same case is with the ports of the Greater Odessa; there is no blockade from Ukraine, the resolution will only begin to work from the 15th of January. Recently, one lawyer went from Mariupol, carrying six bottles of champagne to the Crimea. I told him, “You are from Mariupol, you were attacked, shelled, and you are carrying champagne to the Crimea”. He replied, “Yes, I am, I don’t care that they fired Mariupol, my wife lives there”. We have a tricolour kimono hanging in here. It was Kharkiv women who carried a whole pile of those kimonos. They are very stubborn. They just say, “That’s how we want it”. The local councils do not stand up for the anthem of Ukraine here”.

“Okay, but how can this naval blockade be implemented?”

“If there were more patriots in Odessa, it would be possible to attack ships with small boats when they allegedly go to Skadovsk while really carrying goods to the Crimea. Information on their exits is available. The neutral waters are open to any ships. No fleet is entitled to operate there. The 12-mile zone near the Crimea is also occupied, so this could be done. But we will use this method when we have already tried all other ones. We have more interesting methods to prevent ships from moving further”.

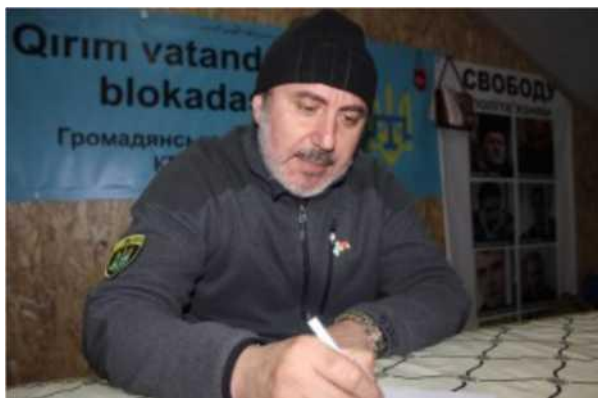

Annex 159

Facebook, *ATR TV Channel*, “*This Is Our Second Victory. First One Was Trade Blockade of Crimea*”, *Liza Bogutskaya Says* (17 August 2017)

(translation)

Annex 160

Tatar-inform.ru, *Mufti of Crimea: “We cannot repeat the mistake we made in 1783”* (13 August 2022)

(translation)

Translation

Tatar-inform.ru, *Mufti of Crimea: "We cannot repeat the mistake we made in 1783"* (13 August 2022), available at: <https://www.tatar-inform.ru/news/muftii-kryma-my-ne-mozem-povtorit-osibku-kotoruyu-soversili-v-1783-godu-5872339>

religion
13 August 2022 08:00

Mufti of Crimea: "We cannot repeat the mistake we made in 1783"

In an interview with "Milliard.Tatar", Haji Emirali Ablaev, Mufti of the Muslims of the Republic of Crimea and Sevastopol, talks about 23 years of work in the local Muftiate, the future of Muslims on the peninsula, as well as relations with the Mejlis*, which did not support the annexation of Crimea to Russia.

"Long story, complicated subject, bitter days"

- How did your family in the Soviet years manage to preserve Islam and pass it on to you?

- Where I lived, in Uzbekistan, in Dalverzin, there were many religious people. They were Muslims: Crimean Tatars and Uzbeks. They observed customs, did namaz, read the Koran. My father and my grandmother read the Koran, we didn't have any problems with it. We have a saying in our people: a bird does what it sees in the nest. I lived and grew up with what we had at home. Apparently, it was ordained by the Most High and He deemed me worthy of serving His religion and His people.

- What did you and your family go through when you returned to your historic homeland? How did Crimea welcome you?

- It's a very long story, a complicated subject, bitter days. We were not welcome in the Crimea. We arrived in 1987. Of course, it was very difficult. We could not get registered. Life was arranged in such a way that if you didn't have a registration permit you didn't exist, you weren't registered anywhere, you couldn't declare yourself anywhere. Every week we had to go through passport control two or three times. Those were difficult times. But thank God, today we live well in our homeland, we have the opportunity to follow our faith, our people live in their native land. May those sorrowful days be gone forever and never be repeated in any person's life. I pray that no nation will ever experience such days. Yes, our future is in our hands. In order for it to be bright, we must be smart, communicate with everyone respectfully, and build dialogue. That is our

responsibility. The religion of Islam is a religion that unites. We want to live in unity, we are working on that and we are on that path. InshAllah, I have great hope that our future will be bright.

- You studied at a madrassa in Manisa and then continued in Lebanon. Could you tell us, how did the studies go, how strong is the Muslim school abroad? Is it possible to say that in today's reality it is no longer necessary to study abroad?

- After the collapse of the USSR in 1991, every nation began to restore its religion. Orthodox Christians, Muslims, and representatives of other faiths began to live according to their religions. It was a difficult path. Young people didn't know religion. But in 1993 the first teachers from Turkey came, and there was an opportunity to get an education.

So we went to Turkey to study. It was extremely necessary, because getting the basics of religious knowledge at home is one thing, but learning the intricacies of religion in a madrassa from lecturers is something completely different. If you ask about the present time, I will tell you that yes, we have madrassas, we graduate khafizes, but this knowledge is not enough. It is very good when there is an opportunity to go somewhere to get knowledge. It's not bad. But I wouldn't recommend Lebanon. It's difficult there. So I wouldn't advise anyone to go to Lebanon to study.

- Where do Crimean Muslims study now?

- After 2014 most of our students study in Tatarstan. I express my gratitude to the Muftiat of Tatarstan for its support. We send our children there to Universities and Quranic courses.

Our students also continue their studies in Turkey. InshAllah, they will all return when they finish their studies. The doors haven't closed, but the situation is a bit complicated, so a lot of students don't go to Turkey, they go mostly to Tatarstan.

The Azov madrassa continues its work. As I've already noted, we have Quranic and Hafiz courses. We have big plans for expansion. With the permission of Allah Almighty, we would like to put them into practice. The heritage of our ancestors - the Zindzhirly Madrassa in Bakhchisaray - has been handed over to our Muftiat. We plan to restore it and recreate the mosque. There are also plans to restore a two-story school near the building of Zindzhirly Madrassa, where Ismail Gasprinsky worked. A science center will open there. By Almighty Allah's permission, this is our idea.



"After 2014, most of our students study in Tatarstan. We send our children there to Universities, to Quranic courses"

Photo: © Salavat Kamaletdinov / "Tatar-inform"

But then again, it is always possible to go abroad and get an education there. Even if we have a higher spiritual education center, it is always good to gain new knowledge. We have big projects and plans.

Today the government supports us. The Head of Crimea **Sergey Valerievich Aksenov** always responds to our projects. Everything will be done, the funds have already been allocated. InshAllah, this Madrassa, this University will also work. We dream about it, Allah Almighty knows the rest. We hope that wishes from a pure heart and with good intentions always come true.

"We cannot repeat the mistake we made in 1783»

- You have been a mufti of Crimean Muslims since 1999 and will hold this position until 2023. Tell us how you felt when you were first appointed to this position and what path, what changes has the Crimean Tatar Muslim community undergone during these years?

- Looking back on those days, of course, they were difficult. Very difficult. I was young, but I already had such a responsibility. Those were very hard days, very hard times. I had no one by my side. Zakir Agha, 80 years old now deceased, worked at the

publishing house. In the construction department there was Server Agha, who was also old. There was one lecturer and Meliha khanum.

If you think back, those were difficult days. But it's been 23 years now, and the difference is colossal. Today we have a team of 40 people working in the Muftiate. Back then there were only four employees. Today there are 40 people working. So there is, of course, a big difference. And the work we do is also big. Our work concerns religion, religious facilities, allocation of land for the construction of mosques. In the villages our communities have been allocated plots of land. This is also handled by the specialists who work here at the Muftiate. I am pleased with each employee, I thank them for their work. If you look at the Muftiate in 1991 and the present one, there is a big difference. Thank God for everything.

- You were an imam in the Zolotoye Pole village. Do you still pay attention to the local mosque?

- Of course, we have a connection. I constantly visit it, I worked there for many years. Before that I lived in the village of Akchora (Dolinnoye village, Kirovskiy district). There is a mosque there too. At that time the Muftiat didn't appoint imams; back then the community itself chose the imam. Today we have a well-established system and imams are appointed. It's a good mosque there, the community is active, they support the



mosque, thanks to them.

"We are in good relations with the state, we work in the legal field of the Russian Federation"

Photo: © Salavat Kamaletdinov / "Tatar-Inform"

- You were a member of the Presidium of the Mejlis of the Crimean Tatar People. The leadership of the Mejlis did not support the annexation of Crimea to Russia. Did you try to influence the Mejlis leadership? How do you feel about them now?

- I'll be honest, we have no connection, and we have nothing to do with them. And the reason for that is one thing - our opinions are divided. We said that as a Spiritual Directorate we would not go anywhere from Crimea, that we would stay in our homeland, that we would defend our religion, our Quran, our people, our mosques here. They chose otherwise. So everyone thinks and does according to their own minds. No one is offended by anyone.

We keep working. We live in our homeland and this topic is closed for us. We don't even have any thoughts of leaving somewhere. It's impossible. Everyone knows for himself how and where to live. But our wish and proposal is to live in the homeland. We explain to our young people that the mistake we made in 1783 cannot be repeated. We have no such right. Knowing that mistake, we cannot repeat it. And those who want us to make this mistake, let them think hard: what will happen to our people tomorrow? Praise be to Allah Almighty, the azan is read five times in our homeland, mosques work, madrassas work, a University works, schools and kindergartens are built. That's why we are satisfied with today's life.

"In the times of Ukraine, mosques were built without registration, land plots were allocated illegally"

- It is known that you actively advocate the return of all religious objects of Muslims in Crimea, promote the construction of mosques, madrassas. Are you yourself satisfied with the result, is there much more to be done? From 2014 to the present day have you been actively working in this direction?

- Of course, in 23 years, the cultural heritage that we inherited from our ancestors - these are places of worship, mosques, madrassas - under the law returned to the property of the Muftiat. Of 100 percent of mosques, we have managed to return about 80 percent, the remaining 20 percent have been completed. We have good relations with the state, we work in the legal field of the Russian Federation. We are waiting for the return of all mosques to our property.

We are waiting because the mosque buildings are used as schools and kindergartens. In order to free them, the state must build other buildings. InshAllah, and the remaining 20% of religious buildings will be returned to the Muftiat and will be opened as mosques, madrassas, and our heritage will be revived.



"Out of 100% of the mosques we were able to return about 80%, we still have 20% left to finish"

Photo: © Mikhail Zakharov / Tatar-Inform

- So there have been a lot of changes since 2014?

- Of course, because everything is done within the law. There are no spontaneous decisions. In the times of Ukraine, mosques were built without registration, land plots were allocated illegally. No one paid any attention to this. It was enough that we returned to our homeland. No, that's not right. So today, everything we did and are doing after 2014 is within the legal framework, officially. That's the way it should be done. If there is no official document, you can't do that. Whatever you have - whether it's a plot, a mosque, a school - everything must be officially registered.

This is the only way to be sure that the younger generation can also use this property. We didn't have official documents until 2014. It was difficult. After all, people's situation with squatting is similar. Our people built houses, but couldn't put them into use. Today, everybody is trying to improve that situation. It should definitely be done. We don't have such problems today.

- How do you see the future for the Crimean Muslim community?

- If we compare today's situation with that of 1999, I can say that the level of religious knowledge and thirst for religious knowledge among our people has increased several times. There is a great difference. Praise God Almighty. Alhamdulillah to the will of the Almighty. There is a big difference. In those years, when we organised events in the Crimea, even religious ones, there were no holidays without alcohol. Bad words, bad manners - all that could happen. But today, when we hold events, I'm very happy to watch our young people. We have educated young people who do not drink alcohol. Young people do namaz, learn the basics of Islam. So we have a bright future. The future of the entire Crimea is bright. The future of all the people living in Crimea is bright. Why am I saying this? If we educate our young people, our children and grandchildren, then people who surround them will do the same. If we don't, no one will do it for us. InshAllah, only good things await Crimea in the future. Everyone lives freely, practicing their religions, which are not forbidden by the Constitution. We have to work hard, not sparing ourselves.

After 2014, we have warm friendly relations with Tatarstan. In 2014 I met Rustam Minnikhanov, we talked about many things. In 1991, they went through everything that we went through in 2014. They went the same way. Rustam Minnikhanov advised us to be reasonable, not to make mistakes, and assured us that our future is bright. Of course, we could not understand each other immediately after our first meeting. I didn't understand what was going on, I was worried about what would happen next. But after the second meeting, I advised the members of the Mejlis (an organization banned in the Russian Federation) to go to Tatarstan and see how the Tatar people lived there. Many went. But our politicians didn't want to listen, and our Spiritual Board chose a different path.

We have long-standing cultural ties with Tatarstan. We have similar languages, the same religion. We are open to each other. I thank the President of Tatarstan, Rustam Minnikhanov, and the Mufti of Tatarstan, **Kamil Hazrat**, on behalf of all our people for their help and support. I would also like to express my gratitude to the first President of Tatarstan, **Mintimer Shaimiev**. We met with him in Tatarstan. He has seen much, knows much, and has extensive experience. His opinion was important to us. I try not to make the same mistakes as in 1783. I thank Rustam Minnikhanov, Kamil Hazrat and Mintimer Shaimiev once again. May Allah grant them his satisfaction in both worlds.

* *The organization banned in the Russian Federation*

" Milliard. Tatar "

Annex 161

TASS, Head of the Council of Muftis of the Russian Federation: Crimean Tatars will be able to regain ownership of their mosques (1 April 2014)

(translation)

Translation

TASS, *Head of the Council of Muftis of the Russian Federation: Crimean Tatars will be able to regain ownership of their mosques* (1 April 2014), available at: <https://tass.ru/obschestvo/1090066>.

Head of the Council of Muftis of the Russian Federation: Crimean Tatars will be able to regain ownership of their mosques

1 April 2014, 18:14

MOSCOW, April 1. /Corr. ITAR-TASS Elena Dorofeyeva, Antonina Maga/.

After Crimea became part of Russia, Crimean Tatars will be able to return mosque and madrassa buildings to their ownership in accordance with the law "On the transfer of state or municipal property to religious organizations".

The Council of Muftis of Russia Chairman Ravil Gaynutdin said this at an ITAR-TASS press conference.

Sharing his impressions of his recent trip to Crimea, he noted that "over the past two decades, many cities, mosques, and madrassas have been in a deplorable condition". In his opinion, now the Crimean Tatars have an opportunity to "return the religious buildings that were once taken away from Muslims to the property of religious organizations".

Mufti visited Crimea on March 27-29 to communicate with co-religionists at the invitation of the Mufti of the republic Emirali Abliev.

Annex 162

RIA, Mufti Speaks about Restoration of Khan's Palace in Crimea (17 February 2022)

(translation)

Translation

RIA, Mufti Speaks about Restoration of Khan's Palace in Crimea (17 February 2022), available at: <https://ria.ru/20220217/dvoretz-1773343741.html>.

RIA NOVOSTI

Religion

17 February 2022 at 03:20 PM

Mufti Speaks about Restoration of Khan's Palace in Crimea

“Muslims are closely monitoring the restoration of the Khan's Palace in Bakhchysarai”, the Crimean Mufti says



© Photo courtesy of the Muslim Religious Board of Crimea

MOSCOW, Feb 17 – RIA Novosti. The Khan's Palace in Bakhchysarai, where the spiritual and cultural components of the life of the Muslims of Crimea are concentrated, is of value to the entire mankind and should be preserved and passed on to the next generations, according to Emirali Ablayev, Chair of the Muslim Religious Board of Crimea (MRBC).

Restoration works are currently underway there, in particular, to eliminate the cracks that have appeared in one of the complex's buildings, he said.

“The Crimean Tatars have many objects of cultural and spiritual significance. But the Khansaray complex occupies the central place. The spiritual, cultural and ethnic components of the life of the Crimean Muslims are concentrated there. It is our duty to preserve and pass it

on to the next generations. We know and are confident that the Khan's Palace is of value not only to the Crimean Tatars but to the entire mankind", the Mufti said.

"Governmental support and the concept to preserve the palace are important for us. For our part, we have done and will do our best toward that end and will continue monitoring the progress of the restoration works" Mr. Ablayev said.

The Crimean Mufti noted that emergency and restoration works are underway in the Khan's Palace, and the Muftiate receives the relevant information on those works from the Ministry of Culture and the Bakhchisaray Reserve. "I would like to emphasize that the works in the Khan's Palace are carried out at the expense of the state program for the socio-economic development of the Crimea. We are in close contact with the Republican Ministry of Culture. The restoration is carried out by professionals according to design documents", he said.

According to earlier reports, a crack appeared in a wall of the Count's Building of the Khan's Palace in Bakhchysarai. However, the planned restoration works inside the building were to begin in April 2022. The Palace was closed to tourists for the day. According to preliminary information, the crack was caused by the rotten structures, Sergey Aksyonov, the head of the Crimea said earlier.

The project is estimated to cost about RUB 10 mln, and the emergency works are planned to be completed by 1 May 2022. Mr. Aksyonov added that a contractor company had already been contracted.

The restoration works in the Khan's Palace complex in Bakhchisaray are part of the state program for the development of the Crimea. The works on four sites of the Palace have already been completed and continue on five other ones. The complex includes a total of 16 sites. The total amount of funds allocated for the restoration stands at RUB 1.9 bln. Several companies offering restoration services are engaged in the project. The works in the entire complex of the Khan's Palace's buildings are planned to be completed in December 2023.

Dated back to the 16th century, the Khan's Palace in Bakhchisaray, which is the former residence of the Crimean Khans, is a historical and cultural monument of global significance. The Palace is part of the Bakhchysarai Historical, Cultural and Archaeological Reserve Museum. It has been subjected to emergency and restoration works for several years.

Annex 163

Suspilne Krym, *Second Floor of Lesya Ukrainka Museum in Occupied Yalta Closed for Almost Five Years* (25 February 2022)

(translation)

Translation

Suspilne Krym, *Second Floor of Lesya Ukrainka Museum in Occupied Yalta Closed for Almost Five Years* (25 February 2022), available at: <https://crimea.suspilne.media/ru/news/3194>.

Suspilne Krym

Second Floor of Lesya Ukrainka Museum in Occupied Yalta Closed for Almost Five Years

By Anastasia Rashko and Katerina Glyanko

25 February at 05:53 PM



Photo: *localway.ru*

The second floor of the Lesya Ukrainka House Museum in the occupied city of Yalta has been closed for restoration for almost five years. *Suspilne Krym*'s reporter found out how the Museum looked like before 2014 and what is happening to it now.

According to Alexandra Visich, the director of the Lesya Ukrainka House Museum in Yalta in 2005-2014, they repeatedly appealed to the authorities, stressing that the Museum needs to have its building repaired and a new exposition.

“In fact, it was understood even at the level of the Verkhovna Rada that this overhaul should be carried out, but, after the fact, it had been carried out by one of Lesya's birthdays and nothing had been done. The local authorities very quickly took advantage of the fact that such need and opportunity existed. Our department had been closed for restoration, which continues to date, and some of the exhibits had been moved to the first floor”, she said.

However, according to Elena Popova, an activist at the Ukrainian Cultural Centre in the occupied Crimea, she was told in September that the restoration is still not underway.

“Today (25th of February – *Editor’s note*), I was told that the first floor would also be closed for restoration, as far as I understood. Initially, there might be just this idea – change the building’s orientation by opening a hotel and letting a state entity in. Government agencies love to sit in such beautiful places. If they begin to actively work with this building and repair it as a museum, they will be accused of sympathies for Ukraine, and no one will like it”, she said.

The activist added that the admission fee to the Lesya Ukrainka House Museum is currently RUB 100 to 150 (UAH 30 to 40).

Irina Schukina, the head of the Lesya Ukrainka Museum in Kiev, noted it is important to preserve any physical monuments of Lesya Ukrainka, the more so because her house is located in Yalta.

“Incredible beauty! As a structure, it is a work of our culture, a cultural monument. Since Lesya Ukrainka consecrated this house with her presence, there can be no question here”, Mrs Schukina said.

Annex 164

Mejlis, *News* (9 September 2013)

(translation)

Translation

Mejlis, News (9 September 2013), available at:
<https://web.archive.org/web/20140702114241/http://qtmm.org/news/index/page/2>.

The Mejlis of the Crimean Tatar People

Official website

The Mejlis of the Crimean Tatar People's Petition to Prevent Cases of Abduction and Forced Disappearance of People in Crimea
 12 June 2014



Adopted by the Mejlis meeting on 12 June 2014

A Working Meeting of Members of the Department for Education in the Crimean Tatar Language with Chairmen of Local Mejlises of the Simferopol Region and Representatives of the Teacher Community
 9 June 2014



9 June 2014

Head of the Mejlis Refat Chubarov issues an Ordinance on Interim Discharge of Duties of the Chairman of the Mejlis of the Crimean Tatar People
 2 June 2014
 Ordinance No. 005-r dated 2 June 2014

Chairman of the Mejlis of the Crimean Tatar People Refat Chubarov Congratulates Teachers and Students of National Schools and Classes on Completing the Academic Year
 30 May 2014



On 30 May 2014, the farewell bells rang in all Crimean schools

The United Nations Forum on Indigenous Issues
 23 May 2014



This year, an important event was the speech given at the Forum by the

leader of the Crimean Tatar people, Mustafa Dzhemilev

“No Nation Can Exist without Its Historical Memory,” Refat Chubarov

18 May 2014



About 30,000 people came to take part in the Crimean Tatar Memorial Rally on 18 May despite all obstacles

Resolution of the All-Crimean Mourning Rally in Memory of Crimean Tatar People Genocide Victims, the 18 May 1944 Deportation and the Decades of Their Forced Detention in Exile

18 May 2014



Adopted by Participants of the All-Crimean Memorial Rally on 18 May 2014

The Procedure for Holding 18 May 2014 Memorial Events Dedicated to the Memory of Crimean Tatar People Genocide Victims

17 May 2014



As approved by a meeting of the Mejlis of the Crimean Tatar People on 17 May 2014

Memorial Public Events Will Be Held

17 May 2014



On 17 May, an extraordinary meeting of the Mejlis of the Crimean Tatar People was held to discuss the issue of holding memorial events dedicated to the 70th anniversary of the genocide of the Crimean Tatar people

Mejlis Chairman Meets Russian Ombudsman

17 May 2014



On 17 May 2014, the Chairman of the Mejlis Refat Chubarov met with the Ombudsman of the Russian Federation, Ella Pamfilova, at the headquarters of the Mejlis of the Crimean Tatar People

Annex 165

*Mejlis, Procedure for Holding 18 May 2014 Memorial Events Dedicated to the Memory of
Crimean Tatar People Genocide Victims (17 May 2014)*

(translation)

Translation

Mejlis, Procedure for Holding 18 May 2014 Memorial Events Dedicated to the Memory of Crimean Tatar People Genocide Victims (17 May 2014), available at: <https://web.archive.org/web/20140728215349/http://qtm.org/новости/4486-порядок-проведения-18-мая-2014-года-мемориальных-мероприятий-посвященных-памяти-жертв-геноцида-крымскотатарского-народа>.

The Mejlis of the Crimean Tatar People

Official website

Procedure for Holding 18 May 2014 Memorial Events Dedicated to the Memory of Crimean Tatar People Genocide Victims

17 May 2014

Procedure for Holding 18 May 2014 Memorial Events Dedicated to the Memory of Crimean Tatar People Genocide Victims

(dedicated to the 70th anniversary of the deportation of the Crimean Tatar people)

(As approved by a meeting of the Mejlis of the Crimean Tatar People on 17 May 2014)

In Crimean rural settlements:

The memorial events will be held in places designated by local mejlises as coordinated with the heads of village/settlement councils.

Memorial event decorations: Crimean Tatar national flags, banners.

Any memorial event should open and end with the performance of the Crimean Tatar national anthem.

The order of the day shall be as follows: the Crimean Tatar national anthem, DUA (prayer), speeches by eyewitnesses of the crime 18 May 1944 crime, veterans and participants of the Crimean Tatar national movement, the adoption of a resolution.

Starting time: 08:00 AM

Closing time: by 09:30 AM

Responsible Persons: Chairmen of local mejlises.

In District Centres and Cities:

At monuments, memorial stones or memorial plaques placed in memory of Crimean Tatar people deportation victims. Specific places will be identified by the regional mejlises in coordination with districts or city managers.

Memorial event decorations: Crimean Tatar national flags, banners.

Any memorial event should open and end with the performance of the Crimean Tatar national anthem.

The order of the day shall be as follows: the Crimean Tatar national anthem, DUA (prayer), speeches by eyewitnesses of the crime 18 May 1944 crime, veterans and participants of the Crimean Tatar national movement, the adoption of a resolution.

Starting time: 11:00 AM

Closing time: by 01:00 PM

Responsible Persons: Chairmen of regional mejlises.

(The time of the meeting may be re-scheduled to an earlier time at the discretion of regional mejlises)

Simferopol

I. In two memorial places; by the memorial stone in the railway station square and at the Salgir Park memorial complex, four flag bearers wearing national costumes shall be posted as honour guards.

Participants of the memorial events will come individually to lay flowers to the memorials and say their prayers and then will proceed, one by one, to the venue of the All-Crimean Memorial Rally to commemorate the Crimean Tatar people genocide victims in the Ak-Mosque microdistrict in the square in front of the mosque.

Flower laying ceremony starting time: 10:00 AM

Closing time: 12:30 PM

Responsible Persons: Chairman of the Simferopol Regional Mejlis.

Spiritual Administration of the Muslims of Crimea (with their consent)

II. The All-Crimean Memorial Rally in Memory of Crimean Tatar People Genocide Victims (Dedicated to the 70th anniversary of the deportation of the Crimean Tatar people)

Venue: Simferopol, Ak-Mosque district, the square in front of the mosque

Start: 01:00 PM

End: 03:30 PM

Responsible Persons: Members of the Organising Committee of the Mejlis of the Crimean Tatar People

Meeting Host: Dilyaver Akyiv

Speakers: Persons appointed by the Mejlis of the Crimean Tatar people. No speeches will be given by any government officials.

Decorations for the All-Crimean Memorial Rally in Memory of Crimean Tatar People Genocide Victims (Dedicated to the 70th anniversary of the deportation of the Crimean Tatar people):

- Crimean Tatar national flags,

- the Crimean Tatar national anthem,
- banners bearing slogans to be approved by the Organising Committee.

At the end of the All-Crimean Memorial Rally, a resolution will be adopted.

Upon completion of the All-Crimean Mourning Rally, all participants will proceed to their places of residence individually and in an orderly manner.

Refat Chubarov,
Chairman of the Mejlis of the Crimean Tatar People

Annex 166

Mejlis, *“No Nation Can Exist without Its Historical Memory”*, Refat Chubarov (18 May 2014)

(translation)

Translation

Mejlis, *“No Nation Can Exist without Its Historical Memory”*, Refat Chubarov (18 May 2014), available at:

<https://web.archive.org/web/20140728205426/http://qtmn.org/новости/4489-ни-один-народ-не-может-существовать-без-своей-исторической-памяти-рефат-чубаров>.

Mejlis of the Crimean Tatar People

Official Website

“No Nation Can Exist without Its Historical Memory”, Refat Chubarov

18 May 2014

This year, the mourning rally of the Crimean Tatars on the 18th of May dedicated to the 70th anniversary of the genocide of the Crimean Tatar people was not traditionally held on the central square in Simferopol but in the Ak-Mechet microdistrict, near the jami.

Despite various obstacles, the event gathered about 30,000 people.

The mourning event began with Ant Etkenmen, the Crimean Tatars’ national anthem, and took place under the Crimean Tatars’ national flags.

Following the performance of the anthem, haji Emirali Abliev, the Mufti of the Crimean Muslims, read a prayer (dua) in memory of the victims of the genocide of the Crimean Tatar people and Reshat Ametov recently killed in the Crimea.

“Glory to Allah, we are already in our homeland, on our land”, the Mufti said. “I would like to say that now we all are very proud. Today, we are on our land and, glory to Allah, we already have a lot – there are jamis and madrasahs. Allah will help us with this. Today, we should not despair or give up because we were not allowed to enter the square. Let no one’s soul hurt about this because, be that as it may, we are in our homeland”.

Aishe Seitmuratova, a veteran of the Crimean Tatar national movement and well-known public figure, recalled in her speech the years of deportation and the struggle for return to the Crimea.

“Helicopters fly over us, but they know that we are not afraid of them because we were not afraid of prisons, we were not afraid of the Soviet authorities”, she said.

“Over the years, one terrible system has brought grief to the lives of the Crimean Tatars that cannot fit in any head”, said Refat Chubarov, Chair of the Mejlis of the Crimean Tatar People. “70 years ago, an entire nation was deported from their homeland. As my mother recalled in Sudak on the day of deportation, it rained very heavily on the 18th of May. Now it is also raining, but we are at home! We are at home and we will always be here! Because thousands and thousands of our compatriots fought to be able to return to their homeland. Our parents, relatives and friends always went to the squares, went through prisons, saw many difficulties. We are at home!”

The mourning rally ended up with a resolution unanimously adopted by its participants.

Answering journalists' questions, Refat Chubarov said the main requirement is the creation of a national-territorial autonomy for Crimean Tatars in the Crimea.

“I have already said that someone in this government is lying. We have heard declarations that security and respect for the Crimean Tatars on the part of the government will be at the forefront. In addition, we have heard that our rights will be restored. That's on the one hand. And on the other hand, we have issues with holding memorial events in memory of the victims of the deportation of the Crimean Tatar people. They wanted to destroy our memory. No nation can exist without its historical memory, especially when it comes to hundreds of thousands of victims in the recent past”, Mr. Chubarov said.

Upon completion of the mourning rally, well-known Crimean Tatar artists and public activists performed on the stage, reciting poems and singing songs related to the deportation.

Annex 167

Euronews, *UN Adopts Russian-drafted Resolution on Ukraine Crisis* (17 February 2015)

USA

Advertisement

UN adopts Russian-drafted resolution on Ukraine crisis

COMMENTS

By Euronews with Reuters • Updated: 17/02/2015



SHARE THIS ARTICLE



The United Nations Security Council on Tuesday called on all parties in eastern Ukraine to stop fighting and implement a European-brokered peace deal as an almost three-day-old ceasefire rapidly began to unravel.

Russia drafted a resolution, adopted unanimously by the 15-member council, in a move that US Ambassador to the UN, Samantha Power, described as "ironic."

Russian Ambassador to the UN, Vitaly Churkin said: "The Minsk agreement must be fully complied with by all sides, said Russia's Ambassador to the UN Vitaly Churkin. "We have to avoid adopting unilateral measures that would contradict the letter and spirit of the document signed in Minsk on the February 12, 2015."

Pro-Russian rebels in Ukraine fought their way into an encircled government bastion and were battling street to street on Tuesday, according to Reuters reports. The rebels say the truce does not apply at all to the main battle front at the town of Debaltseve.

"Russia signs agreements then does everything within its power to undermine them, Russia champions the sovereignty of nations and then acts as if a neighbor's borders do not exist," Power told the Security Council after the vote.



Powered by minute4

"The idea that Russia, which manufactured and continues to escalate the violence in Ukraine has tabled a resolution today calling for the conflict's peaceful solution is ironic to say the least," she said.

The resolution endorsed the peace deal that was reached at all-night talks in the Belarussian capital Minsk last week and called for all parties to implement it.

Advertisement

Advertisement

euronews. Jobs

HIRING NOW

- xqonto
- thermondo
- MessageBird

[View Jobs →](#)

Sponsored



Annex 168

Telegraf, *Poltorak on Disengagement: Agreements with Aggressor are Worth Nothing* (20
October 2016)

(translation)

Translation

Telegraf, *Poltorak on Disengagement: Agreements with Aggressor are Worth Nothing* (20 October 2016), available at: <https://telegraf.com.ua/ukraina/politika/2917869-poltorak-o-razvedenii-dogovorennosti-s-agressorom-nichego-ne-stoyat.html>

Poltorak on Disengagement: Agreements with Aggressor are Worth Nothing

Svetlana Kalatenko | 20 October 2016, 14:50



Ukraine is ready to implement the agreements reached on the withdrawal of troops from the demarcation line, but the agreements with the aggressor are worth nothing.

The Ukrainian Defence Minister Stepan Poltorak has said that Ukraine is ready to implement the agreements reached on the withdrawal of troops from the demarcation line, but the agreements with the aggressor are worth nothing.

According to the Defence Ministry, he said this at a meeting with strategic foreign advisers and ambassadors of the UK, Canada and the Republic of Lithuania.

"We are ready to implement the agreements reached on the withdrawal of troops from the demarcation line, just as we were ready to implement the previous agreements. But the experience shows that any agreements with the aggressor are not even worth the paper on which they are signed," the minister stated.

He stressed once again that Ukraine hopes to solve the problem politically and diplomatically, but this can only be done if it has a strong army.

"We are on a march. This march is towards Europe, the Alliance and democratic values. We are waiting for your help when the Ukrainian army is reformed, in particular, to avoid mistakes and minimise risks during the reform process," he noted.

Poltorak spoke about the strategic documents already approved in the defence sector and about the deadlines set for reforming the Ministry, the General Staff and the Armed Forces of Ukraine. He also said that the State Programme for Development of the Armed Forces of Ukraine was at the final stage of development.

The sides agreed that first of all the advisors needed to get acquainted with the strategic documents and the results of the reform stages that had already been completed.

In his turn, the UK Strategic Advisor General Sir Nick Parker expressed his respect and support for the reform processes that had been launched. In particular, he said that he understands how difficult it is to reform the Ministry when the military operation is underway. He also stressed the importance of working out an algorithm for the work of the group of strategic advisers.

According to him, apart from studying documents, it is necessary to work on building trust, because this is the key to the successful work of the team.

Ms. Jill Sinclair, advisor on the part of Canada, said that the openness that had already developed among all those gathered at the meeting shows the high potential for further cooperation.

Major General Jonas Andriuškevičius, advisor on the part of the Republic of Lithuania, said he had been one of those who had reformed and created the Lithuanian armed forces and knew from his own experience how difficult and lasting the process that awaited Ukraine would be.

Poltorak separately thanked the British, Canadian and Lithuanian Ambassadors for their active public stance in the performance of their duties in Ukraine.

Annex 169

Ukrinform, *Reznikov: Only Normandy Four Leaders Can Change Minsk Agreements* (11 July 2020)

Search



News Subscription Photobank Press-center Releases

Eng

WAR

POLITICS

ECONOMY

DEFENSE

SOCIETY AND
CULTURE

SPORTS

CRIME

ACCIDENTS AND
EMERGENCIES

Contacts

More »

**UKRINFORM**

Ukrainian multimedia platform for broadcasting

Tuesday, 27 September 2022, 19:30



Only Normandy Four leaders can change the format of the Minsk talks.

"The decision on the 'birth' of the Minsk format was made at the level of the Normandy format, so any other decisions related to Minsk can be made only within these consultations. Trilateral Contact Group is a technical and logistical center. Its task is to touch upon the emerging issues, but all decisions should and can only be made by the leaders of the Normandy format," Vice Prime Minister of Ukraine - Minister for Reintegration of the Temporarily Occupied Territories Oleksiy Reznikov said, RBC news agency reports.

According to him, the Normandy format meeting can be held "at a distance", if the leaders of the participating states agree. At the same time, it is realistic to hold consultations in September after fulfilling the obligations of the Paris summit, but only "if there is mutual will of all participants in this process."

Reznikov also noted that a number of provisions of the Minsk agreements of February 2015 did not correspond to today's realities. It is implied that the document outlines the already irrelevant dates of implementation of the agreements, the contact line and the procedure for holding elections in the occupied areas of Donbas until the restoration of Ukraine's control over its border.

"There are a lot of things that no longer work and, therefore, the parties in Minsk cannot agree a priori. This is what our European partners are talking about, starting with the phrase of German Chancellor Merkel that Minsk is not carved in stone. I did not say anything new," the Vice Prime Minister added.

As a reminder, Russia waits for the official comment of Ukrainian authorities on the statement made in Minsk about the need to revise the Minsk agreements. Foreign Minister of the Russian Federation Sergey Lavrov also stated that Kyiv had rejected the agreements, which had been reached at a meeting of political advisers in Berlin, during the meeting of Trilateral Contact Group.

ol



Annex 170

Ukrinform, *Poroshenko Says Minsk Agreements Partially Fulfilled Their Goal* (13 December 2019)

9/27/22, 7:33 PM

Poroshenko says Minsk agreements partially fulfilled their goal

Search



News

Subscription

Photobank

Press-center

Releases

WAR

POLITICS

ECONOMY

DEFENSE

SOCIETY AND
CULTURE

SPORTS

CRIME

ACCIDENTS AND
EMERGENCIES

Contacts

More »

**UKRINFORM**
Ukrainian multimedia platform for broadcasting

Tuesday



Former Ukrainian President Petro Poroshenko has said he believes that the Minsk agreements were justified and partially fulfilled their goal.

He stated this in an interview with Radio Free Europe/Radio Liberty.

"Were the Minsk agreements justified? Of course, they were. Have they fulfilled their goal? Partly yes and partly not. The introduction of a Steinmeier formula, taken out of context in the Kremlin wording, certainly weakened Ukraine's position. Why did they [the Minsk agreements] not achieve complete success? Due to the absolutely destructive blocking position of Russia. This is why we suggested that a position on peacekeepers be introduced, which was fully agreed with the permanent members of the UN Security Council, except for Russia, that are obliged to act as guarantors of Ukrainian sovereignty as part of the Budapest Memorandum and a transitional phase designed for the implementation of a road map of the Minsk agreements, which describes the timing and sequence of all points of all Minsk agreements," Poroshenko said.

At the same time, analyzing the effect of the Minsk agreements, Poroshenko said that the purpose of these documents was to stop Russian aggression, to stop the advance of regular troops of the Russian army, and this task had been fulfilled.

"From the very beginning, the goal was to disrupt the Kremlin project of Novorossiia or Malorossiia, no matter how they called it, which envisaged the destruction of Ukrainian statehood and the dismemberment of Ukraine. This goal was also achieved," he said.

9/27/22, 7:33 PM

Search



WAR

POLITICS

ECONOMY

DEFENSE

SOCIETY AND CULTURE

SPORTS

CRIME

ACCIDENTS AND EMERGENCIES

Contacts

More »



Poroshenko says Minsk agreements partially fulfilled their goal

According to him, it was critically necessary to take the time to build the effective Ukrainian Armed Forces.

"I emphasize, not for the attack, but for the protection of Ukrainian land, so as to substantially increase the cost of the movement of regular units of the Russian Armed Forces on each subsequent meter of our land. And this goal was also achieved. I emphasize again that all three documents of the Minsk agreements were based on the peace plan of President Poroshenko," he said.

Poroshenko said that the formation of a global coalition in support of Ukraine and the demonstration of solidarity around the world with Ukraine was another goal pursued by the Minsk agreements.

"The responsibility for non-compliance with the Minsk agreements was reflected in the application of sanctions by the U.S., G7, EU, Australia, New Zealand, Japan, and all others," he said.

At the same time, he stressed that sanctions are not directed against the Russian people, but remain the only tool at the disposal of the world community to motivate Russia to release Ukrainian land from aggression by the Russian army, as well as to free hostages. According to Poroshenko, this is a concrete practical result of the signing and implementation of the Minsk agreements.

op



Let's get started read our news at facebook messenger >>> [CLICK HERE FOR SUBSCRIBE](#)

TOP NEWS



MEPs condemn Russia's sham referenda in Ukraine



Zelensky dismisses Ukraine's ambassadors to Switzerland and Netherlands



Zelensky's office calls on world to join creation of tribunal against Russian leadership



U.S. sees no sign planning to support invasion of Ukraine

[MORE NEWS](#)

TOP NEWS

While citing and using any materials on the Internet, links to the website ukrinform.net not lower than the first paragraph are mandatory. In addition, citing the translated materials of foreign media outlets is possible only if there is a link to the website ukrinform.net and to the website of a foreign media outlet. Citing and using materials in offline media, mobile apps,

[PUBLICATIONS](#)

[INTERVIEWS](#)

[PHOTO](#)

[TOPICS](#)

[War](#)

[Politics](#)

[AC](#)

[I](#)

Annex 171

Russia Today, *Minsk Deal Was Used to Buy Time – Ukraine's Poroshenko* (17 June 2022)



QUESTION MORE

LIVE

17 Jun, 2022 10:52 / [Home](#) / [Russia & FSU](#)

Minsk deal was used to buy time – Ukraine's Poroshenko

Petro Poroshenko said the Minsk agreements “meant nothing” and claimed credit for giving Kiev enough time to militarize



FILE PHTO. Former Ukrainian President Petro Poroshenko. ©STR / NurPhoto via Getty Images

Petro Poroshenko has admitted that the 2015 ceasefire in Donbass, which he negotiated with Russia, France and Germany as president of Ukraine, was merely a distraction intended to buy time for Kiev to rebuild its military.

He made the comments in interviews with several news outlets this week, including Germany's Deutsche Welle television and the Ukrainian branch of the US state-run Radio Free Europe. Poroshenko also defended his record as president between 2014 and 2019.

Top stories

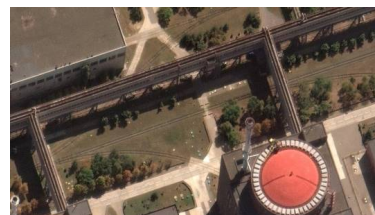

US threatens Russia with ‘catastrophic consequences’

Russian gas pipelines could have been sabotaged – Tagesspiegel

Dmitry Trenin: Russia and the US still have time to learn the lessons of the Cuban missile crisis and prevent a nuclear war

ANALYSIS

Death toll climbs in Russian school shooting

NASA completes ‘planetary defense’ test

Japan responds to expulsion of ‘spy diplomat’

Crimea head discloses future of ‘special military operation’

"We had achieved everything we wanted," he said of the peace deal. "Our goal was to, first, stop the threat, or at least to delay the war – to secure eight years to restore economic growth and create powerful armed forces."

He cited Sun Tzu's stratagems as an inspiration for the deception. Winning a war does not necessarily require winning military engagements, Poroshenko said, calling the deal he made a win for Ukraine in that regard.

Poroshenko failed to be reelected in a landslide vote for President Volodymyr Zelensky, who promised voters that, unlike his predecessor, he would secure peace in Donbass.

For peace we need weapons, Ukraine's ex-Pre...



In the interviews, Poroshenko spoke about his role in negotiating the Minsk agreements, a roadmap for reconciliation between his government and the Donetsk and Lugansk People's Republics. The former president apparently confirmed that Kiev hadn't come to the talks in good faith, but simply wanted a reprieve after suffering a military defeat.

The agreements included a series of measures designed to rein in hostilities in Donbass and reconcile the warring parties. The first steps were a ceasefire and an OSCE-monitored pullout of heavier weapons from the frontline, which were fulfilled to some degree.

Kiev was then supposed to grant general amnesty to the rebels and

Ukraine makes decision on mobilization

Subscribe to RT newsletter to get news highlights of the day right in your mailbox

We offer you the possibility to receive RT's news highlights every Monday, Wednesday and Friday by email.

Subscribe

RT Features

Hijab of contention: Death of a young woman has sparked mass protests in Iran. What's next?

FEATURE

How Yemen's Cold War-era revolution set the

extensive autonomy for the Donetsk and Lugansk regions. Ukrainian troops were supposed to take control of the rebel-held areas after Kiev granted them representation and otherwise reintegrated them as part of Ukraine.

Read more: Ex-president tries to leave Ukraine (again)

Poroshenko's government refused to implement these portions of the deal, claiming it could not proceed unless it fully secured the border between the rebellious republics and Russia. He instead endorsed an economic blockade of the rebel regions initiated by Ukrainian nationalist forces.

Zelensky's presidency gave an initial boost to the peace process, but it stalled again after a series of protests by right-wing radicals, who threatened to dispose of the new Ukrainian president if tried to deliver on his campaign promises.

Kiev's failure to implement the roadmap and the continued hostilities with rebels were among the primary reasons that Russia cited when it attacked Ukraine in late February. Days before launching the offensive, Moscow recognized the breakaway Ukrainian republics as sovereign states, offering them security guarantees and demanding that Kiev pull back its troops. Zelensky refused to comply.











Now an opposition MP, Poroshenko, called on Western nations to provide more and heavier weapons for Kiev so that Ukrainian soldiers can "*do [the West's] job*" and defend Europe from Russia. He also

stage for today's devastating Western-backed war FEATURE

Saints, dog dictatorship and supercops from St. Petersburg: 600 years of Russian comics FEATURE

Podcasts

[All podcasts](#)

-
-  Dishonoring peace? Adriel Kasonta, political analyst and risk consultant
0:00  28:53   
-  CrossTalk, HOME EDITION: Self-determination
0:00  26:22   
-

Read more: Kremlin explains why it doesn't trust Zelensky
Russia sanctions and for his country to join the EU and NATO as soon as possible.

Poroshenko claimed that Russian President Vladimir Putin was the one who broke the Minsk agreements. He claimed credit for Ukraine not falling into Russia's hands within a matter of days, which was the prediction of some Western officials. The country stood up to the attack thanks to military reforms that his government implemented, the former president claimed. Moscow never gave a timeline for its military operation in Ukraine, stating only that it has proceeded as intended.

The Ukrainian official also called for the *"de-Putinization"* of Europe, his own country and Russia itself. He said this meant curbing Russian influence in other nations and toppling Putin. It is the only way to save the world from an *"existential threat"* that, Poroshenko claimed, the Russian leader poses.

You can share this story on social media:

Trends: [Donbass](#), [Ukraine](#)



العربية ESPPY CDEF R

ИНО TV RT A RUPTLY



Annex 172

Roskomnadzor, Data on media outlets registration between 1 January 2016 and
31 December 2016

(translation)

Translation

Roskomnadzor, Data on media outlets registration between 1 January 2016 and 31 December 2016, available at: <https://rkn.gov.ru/mass-communications/smi-registration/p885/>.

Data on media outlets registration between 01.01.2016 and 31.12.2016

Overall number of licenses issued: 6272

Overall number of licenses excluded from the register: 6048, from which

- by judicial decision: 351 – CO, 1583 – TD.

- by applicants' decision: 1669 – CO, 2445 – TD.

No.	Name of the Registering Body	Number of Newly Registered Media Outlets			Number of Re-Registered Media Outlets			Number of Media Outlets with Amendments			Number of Annulled Media Outlets			TOTAL Registered Licenses
		PM	EL	IA	PM	EL	IA	PM	EL	IA	PM	EL	IA	
1	Central Office	643	1330	46	765	257	5	358	210	7	1406	588	26	3621
2	Altai Krai and Altai Republic	13	2	1	27	7	0	5	7	0	35	6	0	62
3	Amur Oblast	4	3	0	5	1	0	1	0	0	17	7	1	14
4	Arkhangelsk Oblast and Nenets Autonomous Okrug	11	3	0	4	7	0	3	0	0	49	11	2	28
5	Astrakhan Oblast	6	3	0	2	5	0	5	0	0	28	4	2	21
6	Belgorod Oblast	5	1	0	25	7	0	0	0	0	24	14	0	38
7	Bryansk Oblast	2	2	0	0	7	0	1	1	0	17	11	1	13
8	Vladimir Oblast	12	7	4	5	6	0	2	4	1	39	29	2	41
9	Vologda Oblast and the Republic of Kalmykia	20	6	2	7	6	0	3	3	0	72	31	0	47
10	Vologda Oblast	11	1	0	9	7	0	0	0	0	28	13	0	28
11	Voronezh Oblast	6	2	0	6	0	0	3	0	0	38	21	4	17
12	Far-East Federal District	8	9	1	11	8	0	0	3	0	51	12	3	40
13	Emisey Department	17	14	0	11	8	0	3	3	0	69	32	0	56
14	Zabaikalsky Krai	2	2	0	4	4	0	4	0	0	10	1	0	16
15	Ivanovo Oblast	5	5	0	4	5	0	0	0	0	19	4	0	19
16	Irkutsk Oblast	21	10	2	12	8	0	7	5	0	93	24	1	65
17	Republic of Kabardino-Balkariya	0	0	0	3	0	0	0	0	0	7	0	0	3
18	Kaliningrad Oblast	15	2	0	13	2	0	3	1	0	44	20	1	36
19	Kaluga Oblast	4	2	0	5	3	0		0	0	21	29	0	14
20	Kamchatka Krai	6	1	3	4	5	0	1	0	0	11	5	0	20
21	Republic of Karachaevo-Cherkessiya	3	0	0	2	0	0	0	1	0	4	0	0	6

22	Kemerovo Oblast	8	7	0	5	11	0	0	0	4	0	35	26	1	35
23	Kirov Oblast	22	4	1	32	2	0	0	0	0	0	42	22	0	61
24	Kostroma Oblast	6	4	0	3	7	0	0	0	0	0	13	1	0	20
25	Kurgan Oblast	3	0	0	5	3	0	0	0	1	0	7	4	0	12
26	Kursk Oblast	9	3	0	4	3	0	0	1	1	0	15	1	0	21
27	Lipetsk Oblast	9	2	1	1	3	0	0	1	0	0	9	7	0	17
28	Magadan Oblast	2	1	0	1	5	0	0	0	0	0	4	2	0	9
29	Murmansk Oblast	4	4	0	5	11	0	0	0	2	0	23	4	0	26
30	Novgorod Oblast	11	2	0	4	2	0	0	0	0	0	7	4	1	19
31	Omsk Oblast	11	4	0	8	2	0	0	0	0	0	40	10	4	25
32	Orenburg Oblast	7	2	0	18	11	0	0	0	0	0	28	28	0	38
33	Orel Oblast	5	5	1	2	3	0	0	0	1	0	15	6	0	17
34	Penza Oblast	6	6	0	3	2	0	0	1	0	0	13	9	0	18
35	Perm Krai	34	7	0	15	7	0	0	6	1	0	48	28	2	70
36	Privolzhsky Federal District	21	8	6	22	16	0	0	7	2	1	60	20	1	83
37	Primorsky Krai	7	6	0	5	29	0	0	1	2	0	38	11	1	50
38	Pskov Oblast	1	5	0	2	3	0	0	0	0	0	11	6	2	11
39	Republic of Bashkortostan	35	10	3	16	7	0	0	5	1	0	79	11	0	77
40	Republic of Buryatia	4	3	0	2	2	0	0	1	0	0	30	11	0	12
41	Republic of Dagestan	3	3	0	30	7	0	0	0	0	0	32	7	0	43
42	Republic of Ingushetia	1	0	0	0	0	0	0	0	0	0	2	0	0	1
43	Republic of Karelia	12	1	0	4	1	0	0	0	0	0	22	3	0	18
44	Republic of Komi	3	5	0	23	6	0	0	0	0	0	42	24	0	37
45	Republic of Crime and the City of Sevastopol	25	10	1	5	4	0	0	0	0	0	12	0	0	45
46	Republic of Mary El	5	3	0	4	4	0	0	2	0	0	9	5	0	18
47	Republic of Mordovia	4	3	0	2	2	0	0	1	0	0	12	6	0	12
48	Republic of Sakha (Yakutia)	11	2	0	9	10	0	0	1	0	0	39	4	0	33
49	Republic of North Ossetia-Alaniya	3	1	0	3	1	0	0	0	0	0	11	3	0	8
50	Republic of Tatarstan (Tatarstan)	16	12	0	16	24	0	0	6	6	0	97	22	5	80
51	Rostov Oblast	16	7	2	11	8	1	9	3	1	1	79	17	1	58
52	Ryazan Oblast	6	4	1	1	2	0	0	2	1	1	21	4	0	18
53	Samara Oblast	17	3	0	8	9	0	0	0	1	0	174	24	2	38
54	Saratov Oblast	5	2	1	1	8	0	0	2	9	1	73	39	0	29
55	North-Western Federal District	73	11	0	54	14	0	0	9	7	0	248	27	3	168
56	North-Caucasian Federal District	7	5	0	5	11	0	0	2	6	0	25	19	1	36
57	Siberian Federal District	14	6	0	15	10	0	0	2	1	0	85	25	3	48
58	Smolensk Oblast	5	4	0	3	0	0	0	0	1	0	15	11	0	13
59	Tambov Oblast	5	4	0	5	8	0	0	1	0	0	14	9	2	23
60	Tver Oblast	11	5	1	2	12	0	0	0	3	0	18	20	1	34
61	Tomsk Oblast	8	6	0	2	2	0	0	0	1	0	10	7	0	19
62	Tula Oblast	6	2	0	28	5	0	0	1	1	0	18	7	0	43
63	Tyumen Oblast, Khanty-Mansi	28	10	1	8	28	5	0	23	2	0	162	95	1	105

Annex 173

ANO OKTRK, Letter, 8 February 2023

(translation)

Translation

ANO OKTRK, Letter, 8 February 2023.

**AUTONOMOUS NON-COMMERCIAL ORGANISATION
"PUBLIC CRIMEAN TATAR BROADCASTING COMPANY"
(ANO OKTRK)**

Ref.# 106 dated 08.02.2023

In response to: ref.#1849/gr dated 01.02.2023

To: <...>,

Member of the Board,

Director of the Legal Department of the Ministry of Foreign Affairs of the Russian Federation

On the provision of information

on the case 'Ukraine v Russian Federation'

in the International Court of Justice

Dear Yevgeny Timofeyevich!

Regarding the issues raised in your letter, please be informed of the following.

The Autonomous Non-profit Organization «Public Crimean Tatar Television and Radio Company" (hereinafter - the 'ANO OKTRC') is a round-the-clock information and entertainment Crimean Tatar media resource, which occupies a leading position in the Republic of Crimea. ANO OKTRK was established in accordance with Order of the Council of Ministers of the Republic of Crimea No. 507-r of 09.06.2015 "On the creation of an autonomous non-profit organization "Public Crimean Tatar TV and Radio Company" in accordance with Decree of the President of the Russian Federation No. 268 of 21.04.2014 "On measures for the rehabilitation of the Armenian, Bulgarian, Greek, Italian, Crimean Tatar and German peoples and state support for their revival and development".

The staff of the ANO OKTRK is 150 people. ANO OKTRK comprises 3 media outlets:

1. Millet (The Nation) TV channel,¹
2. Vatan Sedasi (Echo of the Motherland) radio channel,² and
3. Millet Network Publishing.³

¹ Registered by the Federal Service for Supervision of Communications, Information Technology and Mass Media - certificate EI #FS77-62701 dated 10 August 2015. The media registration record has been amended EI No. FS77-81699 of 19 August 2021.

URL: <https://rkn.gov.ru/mass-communications/reestr/media/?id=586883&page=>

²Registered by the Federal Service for Supervision of Communications, Information Technology and Mass Media - certificate EI No. FS77-62700 dated 10 August 2015. The media registration record has been amended - registration number EI No. FS77-81700 of 19 August 2021. URL: <https://rkn.gov.ru/mass-communications/reestr/media/?id=586884&page=>

³Registered by the Federal Service for Supervision of Communications, Information Technology and Mass Media (Roskomnadzor) - Certificate EI no. FS77-81701 of 19 August 2021. URL: <https://rkn.gov.ru/mass-comniunications/reestr/media/?id=88183> I

According to the licence conditions⁴ the volume of broadcasting for both the TV channel and the radio channel is 168 hours a week (24-hour broadcasting).

The media registration certificates stipulate as follows:

1. Media distribution territory: Russian Federation, foreign countries;
2. The radio channel is allowed to broadcast in Crimean Tatar, Russian and Turkish;
3. the TV channel and online publication is allowed to broadcast in Crimean Tatar and Russian.

The registration procedure for media outlets founded by ANO OKTRK was carried out in a free, impartial and unbiased manner in accordance with the general procedure for all media. The media outlets conduct their activities independently and freely.

1. The share of broadcasting in Crimean Tatar in the total broadcasting time of the ANO OKTRK is not less than 40%;
2. The share of the Republic of Crimea territory covered by digital television signal is not less than 90%.
3. State subsidies are provided from the national budget to cover costs. For example, ANO OKTRK received 164,154,937.76 roubles in 2022 and is scheduled to receive 165,300,000.00 roubles in subsidies in 2023.

The channel started broadcasting on 01.09.2015 around the clock, in two languages: Crimean Tatar and Russian. The share of broadcasting in Crimean Tatar in 2022 is 46.8 per cent of the total airtime (46.5 per cent in 2021). The share of broadcasting in Crimean Tatar is achieved by producing its own content. The Millet TV channel broadcasts 22 projects: 14 in Crimean Tatar, 6 in both Crimean Tatar and Russian, and 2 in Russian. The share of its own content produced in the Crimean Tatar language in 2022 was 84.27 percent (80.4 percent in 2021). Besides, Millet TV dubs TV films and cartoons in the Crimean Tatar language. In 2022, 141 films and cartoons were dubbed in Crimean Tatar and broadcast for a total of 65 hours and 36 minutes.

Millet is guided exclusively by the interests of its viewers, most of whom are residents of the Republic of Crimea. Materials and broadcasts are made on any topical and pressing socio-political issues. Problematic topics are also to be found among them. Often, viewers suggest the topics of TV stories directly. The programme 'Haberler' (news) broadcasts a segment called 'People Speak' which is about the problems of the residents of a village, a district or a street (lack of water supply or electricity, roads in need of repair or places in kindergarten, etc.). Materials are produced after a request from local residents to the channel's editorial office. The problems voiced in the stories are promptly resolved by local and national authorities. In more than seven years of work, the channel's journalists have never encountered any attempts to hinder their work on the part of government officials.

All of Millet's projects are devoted to promoting the culture, traditions, history and language of the Crimean Tatar people and preserving interethnic peace and harmony in the Republic of Crimea, for example, the morning entertainment show '**Meraba, Saba!**' (two hours of live broadcasting in the Crimean Tatar language every day). The hosts and guests of the programme talk about the main events in the life of the people. The guests are Crimean Tatar musicians, artists, craftsmen, athletes, historians, etc. They discuss both the current agenda and festivities and anniversaries in the history of the people. Development of various forms of folk crafts, teaching of the Crimean Tatar language, new

&page=

⁴License for television broadcasting of the television channel Millet, per. number L033-00114- 77/00059623 dated 28.08.2015. Valid until 28.08.2025 URL: <https://rk.gov.ru/mass-communications/reestr/teleradio/?id=%CB033-00114-77%2F00059623>

License for radio broadcasting of Vatan Sedasy radio channel, per. number L033-00114- 77/00059631 dated 28.08.2015. Valid until 28.08.2025. URL: <https://rkn.gov.ru/mass-communications/reestr/teleradio/?id=%CB033-00114-77%2F00059631>

books, textbooks, etc.

The Yurt Nefesi programme is hosted by representatives of Crimean Tatar intelligentsia. In a half-hour interview they talk about their activities, achievements and historical figures who contributed greatly to the development of the language and culture of Crimean Tatars.

The weekly programme '**Tek arzum Vahan**' is a project about the people's return to their homeland, the traditions and customs of Crimean Tatars and the promotion of national culture. It is an hour of live broadcasting in Crimean Tatar. The guests are usually 'ordinary people' - those who have achieved recognition in their field of activity in their town or village. Viewers have an opportunity to talk to the guests live on air by making phone calls. The programme is broadcast in Crimean Tatar.

Tarikh izleri is a weekly project about the history of Crimean villages. The half-hour programme, broadcast in Crimean Tatar, tells not only about the past but also about the present of the settlements. The heroes of the programme are locals - the history of the village is interwoven with stories about their past and present and the history of their lives.

Miras is a weekly programme broadcast in Crimean Tatar. It discloses history, culture, literature, language, folklore, art and traditions of Crimean Tatars through its "heroes": ancient architectural structures, works created by talented artists in ancient techniques, traditions and customs, household features of Crimean Tatars lost over the centuries.

Vatan Khatyrası is a weekly programme about important historical figures that have contributed to the development of the Crimean Tatar people or achieved international recognition. In essence, it is a 15-minute documentary about the biography and achievements of the protagonist. The heroes of the issues are: poets, writers, public figures, singers, musicians, dancers, choreographers, artists, teachers, scientists and researchers, masters of arts and crafts, heroes of the Great Patriotic War, etc.

The children's entertainment and educational TV programme **Erketai** is broadcast once a week in the Crimean Tatar language. Each broadcast is joined by a talented child presenter. The program offers viewers informative columns (study of their native language, Crimean Tatar cuisine etc.) and special reports about children who participate in the broadcast. Another children's programme is **Yukou Time**. It comes out every evening and aims to prepare children for bed. In the program, the host tells children Crimean Tatar folk and author's fairy tales. It is followed by a cartoon dubbed into the Crimean Tatar language.

'**Ana yurtun - altyn beshik**' is a programme in which representatives of the people (teachers, musicians, athletes, etc.) talk about their views on various spheres of life, the present and future of the Crimean Tatar people.

Religious programmes '**Diniy Subet**' and '**Khyzmet Ve Bereket**'. These are broadcast in Crimean Tatar and are produced jointly with the Spiritual Administration of Muslims of the Republic of Crimea and Sevastopol. In the first programme, Aider Ismailov, Deputy Mufti of Crimea, talks about the norms of traditional Islam and answers viewers' calls live. In the second, imams from various parts of Crimea talk about the life of religious communities on the peninsula.

Vahan Sedasy radio broadcasts the **Kechken Asyrnyn Musykasi** project (broadcast from Monday to Thursday), which introduces listeners to retro music - popular Crimean Tatar folk and folk songs of the last century. **Musika Ezgilsri** programme (broadcasted once every fortnight) features new songs by Crimean Tatar performers. Also in the weekly project **Tilim-baylygym**, university teachers, school teachers and other guests who contribute to the preservation and development of the Crimean Tatar language are given the opportunity to talk about their activities and promote the study of the

Crimean Tatar language.

Also on the radio is a weekly religious-educational project called **‘Islyam nuru’**. The programme is produced jointly with the Spiritual Administration of Muslims of the Republic of Crimea and Sevastopol. It speaks about the intricacies of Islam. The guest of the program is a teacher of Islamic studies. Listeners can call in live and ask their questions about religion. In the news items, correspondents of Millet TV channel talk about the life of Crimean Tatar people.

The television channel Millet holds telemarathons devoted to festive and commemorative dates. During the holy month of Ramadan, for example, 30 daily one-hour live broadcasts in the Crimean Tatar language were aired, featuring representatives of the clergy, opinion leaders and other representatives of the Crimean Tatar people. The month ended with a festive three-hour thematic live broadcast in the Crimean Tatar language, featuring, among others, Haji Emirali Ablaev, Mufti of the Republic of Crimea and the city of Sevastopol. Telemarathons were also held on Eid al-Adha, Mother Language Day, Victory Day and the Day of Remembrance of the Victims of the Deportation of Peoples from Crimea.⁵

Millet also filmed and aired 18 concerts in 2022 featuring Crimean Tatar pop stars and folk song and dance groups, as well as performances by the Crimean Tatar Academic Musical and Drama Theatre in the Crimean Tatar language.

Every year, the Millet TV channel holds a competition for the Millet Menligi (Public Recognition) Award, in which people choose the most worthy representatives from among Crimean Tatars in 10 nominations by voting. The winners are awarded with memorable prizes and gifts, video clips are shot about them and they are invited to live broadcasts on TV. Millet Menligi contest is a public socio-cultural project implemented to recognize the merits of leaders and managers of production and social complexes, public and non-profit organizations, figures of science, education, healthcare, culture, art, sports, who made a significant contribution to social and public life of the Republic of Crimea and, in particular, Crimean Tatars, including children and youth with an active civic position, living in the Republic of Crimea and express public recognition of their merits.

In 2022, Millet TV channel filmed documentaries about the deportation of the people from Crimea (‘The Long Road Home’) and about famous Crimean Tatars who contributed to the history and culture of the people: about the singer Fevzi Bilyalov, composer Asan Refatov who wrote the only opera in Crimean Tatar language, and about the pilot of the Great Patriotic War, Hero of the Soviet Union Abduraim Reshidov. Millet is currently filming two documentaries about the composer Ilyas Bakhshish and the master gunsmith, chaser, ornamentalist and jeweller Amet Kalafatov.

Films of 2022:

- ‘Interrupted melody of life’ (Asan Refatov)⁶
- ‘Fevzi Bilyalov: a singer for all times...’⁷
- ‘The Long Road Home’ (a film about the return of people to their homeland after deportation)⁸
- ‘Abduraim Reshidov. Battle for the Motherland’.⁹

Films made in the past:

- ‘Rustem Kazakov: Being the First’¹⁰

⁵<https://trkmillet.ru/specials/marafoni/>

⁶ <https://trkmillet.ru/program-episode/'dokuinentalniv-illm-prervannaya-ine>

⁷ <https://trkmillet.ru/program-episode/dokumentalniy-film-fevzi-bi-lyalov>

⁸ <https://trkmillet.ru/program-episode/dokumentalniy-film-dolgaya-doroga/>

⁹ https://trkmillet.ru/program-episode/_dokuinentalniy-filin-abduraim-reshi/

¹⁰ <https://trkmillet.ru/program-episode/rustem-kazakov-bit-pervim-dokumen>

- ‘The Age - Amet Khan Sultan’¹¹
- ‘Fevzi Yakubov.’
- ‘Alime Abdennanova’
- ‘Kyrym Evlyatlary’ (dedicated to the return of the people to their homeland)
- ‘Haitarma of Victory’ (about the participation of Crimean Tatars in the Great Patriotic War)
- ‘Khydyrlez’ (about the traditional Crimean Tatar spring festival)
- ‘Aleshli yollar Kuresh Peshinde’, (dedicated to Akim Jemilev)
- ‘Bekir Umerov’
- ‘Chalbash Emir-Usein’
- ‘Noman Chelebijan’
- ‘Ismail Gasprinsky.’

The activities of various diasporas, including the Ukrainian diaspora, are covered if there is a newsworthy event. In particular, three episodes of the project ‘Peoples of Crimea: Diversity of Unity’ were devoted to Ukrainians in Crimea; the programme participants talked about Ukrainian culture, some of them speaking in Ukrainian.¹²

Digital signal coverage in the Republic of Crimea amounts to 95 per cent of the territory of the Republic of Crimea, as confirmed by data provided on the official website of the FGUP ‘Russian Television and Radio Broadcasting Network’, ‘Radio and Television Broadcasting Centre of the Republic of Crimea’.

Broadcasts are available in the Russian Federation as well as in the following foreign countries: Ukraine, Turkey, Georgia, Azerbaijan, Turkmenistan, Uzbekistan, Tajikistan and Kyrgyzstan.

General Director

(signature)

L.L. Vejatova

¹¹ <https://trkmillet.ru/program-episode/yepokha-amet-khan-sultan>

¹² <https://trkmillet.ru/program-episode/narodi-krima-raznoobrazie-edinstva-16>

Annex 174

NTS, *Scientists Discover Secrets of Ancient Necropolis on Tavrida Highway near Sevastopol – Sevastopol Independent TV* (13 July 2018)

(translation)

Translation

NTS, *Scientists Discover Secrets of Ancient Necropolis on Tavrida Highway near Sevastopol – Sevastopol Independent TV* (13 July 2018), available at: <https://nts-tv.com/news/uchyenyte-otkryvayut-tayny-drevnego-nekropolya-raspolozhennogo-na-puti-trassy-tavrida-pod-sevastopole-7915/>.

Scientists Discover Secrets of Ancient Necropolis on Tavrida Highway near Sevastopol – Sevastopol Independent TV

By Natalia Danilova, Mikhail Zhuravsky, Vitaly Kozlovsky, and Andrey Bezhentsev, Sevinformburo

On the threshold of discovery: NTS's film crew visited the excavations of the necropolis of the fourth century A.D. Near the village of Frontovoye, an expedition of the Institute of Archaeology of the Russian Academy of Sciences is studying hundreds of burials. There are a lot of finds – but the more of finds, the more questions arise. The answers to those questions are not easy to find right away, but the data collected will be systematised and analysed down to the smallest strokes in the near future in order to get the whole picture.

Scientists of the Russian Academy of Sciences call the ancient necropolis near the village of Frontovoye in the construction area of the Tavrida Highway's Sevastopol section the discovery of the year. An unprecedented monument of the past, both its scale and condition are impressive. Miraculously, the "black diggers" bypassed this area. Therefore, almost every burial is a true treasure for scientists. Every day gives unique finds and discoveries.

ALEXEY SVIRIDOV, Research Fellow at the Institute of Archaeology of the Russian Academy of Sciences: *"This large burial ground existed for almost 250 years: from the beginning of the second century to the end of the fourth century A.D. And, judging by the excavated burials, we are dealing with an unusual population. Apparently, this settlement was quite large – perhaps, even an urban circle. We believe this settlement should be located closer to the Belbek River – one terrace lower. However, this issue has not yet been resolved geographically".*

On average, it takes a couple of days to clear one burial. This work is painstaking and responsible – after all, everything must be left intact and strictly in its place. But with each passing minute, the brown dust of the past centuries recedes, exposing the whitish bones. Together with them, artifacts are revealed to the human eye – in all their diversity.

OLGA BARANOVA, a student of the Moscow Theological Academy: *"Most likely, it was a woman because there are decorations, a vessel, and a dish here. We use brushes and various knives. If the items are too small, then we use smaller brushes and smaller knives".*

Archaeologists have already discovered about two hundred burials in the territory of the necropolis. 150 of them have already been cleared, and their valuable contents have been raised to the surface. The primary data obtained during the excavations are summarised on site. Although an in-depth analysis of this data will be only carried out upon completion of the expedition, some interesting conclusions have already been drawn. For example, we can talk about the diversity of the traditions of this community. Some people buried the dead in pits with

niches – the so-called “kerfs”. Other used ordinary graves – here we can find cremated remains and burials in amphorae. A special burial complex is situated on a separate site.

“We are in the south-eastern part of the necropolis. The burial complexes here are different – ground crypts. They are smaller in number but larger in size and depth. It would seem that there is no one at the excavation now – but basically everyone works at the bottom. At a depth of two or three meters, the burial chambers are being cleared”.

In such chambers, archaeologists even found burials of warriors with weapons and equipment. For their time, the crypts had a rather sophisticated design.

ALEXEY SVIRIDOV, Research Fellow at the Institute of Archaeology of the Russian Academy of Sciences: *“A crypt consists of two parts: an inclined corridor – “dromos” – and a burial chamber. This sloping corridor is a kind of “road to the other world”. People burying their relatives went down through this corridor to the vaulted burial chamber. These are family tombs: they contain four or five buried people and a huge amount of equipment”.*

Unfortunately, it was the complex of crypts that once suffered from robbers.

VICTOR ZAKARZHEVSKY, a member of the expedition: *“We started this morning. It is a burial chamber. You can see bones, but they lie in different parts – we can assume this burial has been robbed”.*

But it was not our contemporaries who robbed these burials. And this is good luck, members of the expedition say. Ancient tomb raiders hunted for valuables – they were not interested in dishes, costume jewellery or other trifles. However, these untouched items are worth their weight in gold for today’s researchers. By the way, apart from the typical, common items, there are also custom-made, amazing things like this brooch – “fibula”.

ALEXEY SVIRIDOV, Research Fellow at the Institute of Archaeology of the Russian Academy of Sciences: *“It was decorated with stone inserts – there are three of them. There are no more such fibulae found in the southwestern Crimea today, this one is not local, it is from some other culture. This find is definitely unique for this region. Here is a couple, you see: two earrings, and a bronze incense bottle”.*

One of the main mysteries the necropolis poses to scientists is who were those people who have found their posthumous refuge here. The Crimea is a crossroads of cultures – a large cauldron where various ethnic groups have mixed for thousands of years. Journalists were quick to announce the Scythian roots of the buried. But archaeologists believe this is a misconception as most of the graves date back to a later period. At that time, representatives of different peoples jointly created a new chapter of the chronicle of our native land. These finds indicate a Roman, Alan and German traces...

NATALIA DANILOVA, a reporter: *“This is the burial of a poor member of that community – a modest bracelet is the only jewellery we see here. However, the remains themselves are excellently preserved. It would be incredibly interesting to find out the appearance of this man – that is a task for anthropologists”.*

These people have rested in the Crimean land for at least seventeen centuries. And now they have returned from the depths of oblivion and eternal sleep to reveal their secrets to us, people

of the twenty-first century. The unique “city of the dead” will soon disappear under the asphalt roadbed and utility lines of the Tavrida Highway. But before that, scientists will raise all the bone remains, jewellery and funerary equipment from the pits and crypts. All these items will be carefully preserved in museum collections. A large-scale scientific work describing the life of an as yet unknown settlement will be published in the middle of next year.

Annex 175

Russian Gazette, *3,500+ Years Old Artefacts Found on Tavrida Highway Construction Site* (20
May 2021)

(translation)

are completed, the place where the Kil-Dere burial ground was located will be covered with soil, and the slope will be reclaimed and sown with grass. The new highway will pass through the former territory of the settlement of Dezdar-Dere.

Annex 176

Financial Times, *Ukraine Imposes Economic Blockade on a Blacked-Out Crimea* (23 November 2015)

Prepare for the year ahead with the FT's unrivalled insights for leaders.

Subscribe and save 50%

European companies

Ukraine imposes economic blockade on a blacked-out Crimea

Kiev responds to Russia's demands to restore power by placing embargo on freight shipments



A Crimean Tartar flag draped around a pile of broken power lines © EPA

Roman Olearchyk in Kiev and Jack Farchy in Moscow NOVEMBER 23 2015



Receive free European companies updates

We'll send you a *myFT Daily Digest* email rounding up the latest European companies news every morning.

Sign up

Ukraine responded to Russia's demands to restore power to a blacked-out Crimea by imposing a blockade on all freight shipments to the Russian-occupied peninsula on Monday.

Kiev also refused to offer any timetable to resume electricity supplies to Crimea a day after a suspicious explosion on a transmission line wiped out nearly all electricity to the peninsula's 2m inhabitants.

Ukraine's unusually bold move risks deepening a stand-off with Russia at a time when tensions between the two nations have been creeping up again.

There has been a worrying increase in fighting in recent days with Moscow-backed separatist

rebels in eastern Ukraine. Meanwhile, the Kremlin has also been threatening fresh trade restrictions should Ukraine follow through with plans to introduce a free-trade agreement with the EU next year.

The weekend blast was preceded by a blockade of the power lines near the border by a group of Ukrainian nationalists and ethnic Crimean Tatars, raising suspicions of sabotage.

Those groups are demanding an economic boycott of Crimea as a protest against Russia's persecution of pro-Ukrainian groups in Crimea, which Moscow annexed in 2014 in response to an uprising that gave rise to Ukraine's pro-western government.

The power cut is a reminder of Crimea's extraordinary dependence on Ukraine — even after the annexation. It still relies on the mainland for most of its electricity, drinking water and many of its consumer goods.

“

Crimea is a territory of Ukraine and we will protect the legitimate interests of Crimean Tatars and all Ukrainians living in the occupied territory

Petro Poroshenko, Ukraine's president

Moscow has committed \$5bn to build a bridge and railroad, although such projects will take years to complete. In the meantime, it has relied on ferries to supply Crimea, where most of its Black Sea fleet is based.

Petro Poroshenko, Ukraine's president, announced the blockade on Monday afternoon as protesters blocked work crews from repairing damaged power lines.

“We are really concerned over the situation in Crimea. Hundreds of thousands of Ukrainians, including Crimean Tatars, are facing brutal pressure from the Russian authorities now,” Mr Poroshenko said. “Crimea is a territory of Ukraine and we will protect the legitimate interests of Crimean Tatars and all Ukrainians living in the occupied territory.”

The nationalists and Tatars did not claim credit for blowing up the transmission lines and Ukrainian authorities have not directly blamed them. But obvious sympathies have prompted suspicion of co-ordinated action.

“Most likely this was not a surprise for the government,” Dmytro Marunich, a Ukrainian energy expert, said referring to the power line blasts. Although baffled like many other analysts trying to make sense of it, he speculated it “could be” an attempt by Kiev to gain leverage over Moscow through a sort of hybrid counter-attack — a reference to covert tactics used by Moscow in seizing Crimea and engineering a proxy war in Ukraine's far east.



Russian officials suggested they expected power supplies to Crimea to be restored within hours once the workers got access to the site. However, the head of the peninsula’s Russian-backed government on Monday told residents that stable electricity might not be secured until late December, when power cables from mainland Russia would be laid underwater. Serhiy Aksyonov also urged Crimeans not to panic, insisting there were stable supplies of food.

There was no immediate comment from Russian president Vladimir Putin, and officials in the EU or US were muted in their response.

However, Dmitry Pushkov, head of the foreign affairs committee of Russia’s lower house of parliament, accused Ukraine of attempting to provoke Russia and win back western attention.

“

The actions of Kiev against Crimea are an attempt to raise the temperature of the conflict with Russia and bring the west’s attention back to Ukraine

“The actions of Kiev against Crimea are an attempt to raise the temperature of the conflict with Russia and bring the west’s attention back to Ukraine — without which the regime will simply crumble,” he tweeted.

Konstantin Kosachev, head of the foreign affairs committee of Russia’s upper house of parliament, said the situation demonstrated “at a minimum, the weak control of the Ukrainian authorities in ensuring security of energy supplies, and at most,

a conscious incitement of this type of act of sabotage”.

Other Russian officials sought to play down the seriousness of the situation and highlighted the actions Russian and local authorities were taking to resolve the crisis.

Dmitry Kozak, Russia's deputy prime minister and head of the government commission on Crimea, said Russia would speed up construction of an energy link between Crimea and the Russian mainland across the Kerch Strait. "By the middle of December, the acuteness of Crimea's energy problem will be significantly reduced," he said.

This story will close to new comments at 11:30pm London Time on November 23rd

[Copyright](#) The Financial Times Limited 2023. All rights reserved.
